



***Model YLPA Air-to-Liquid Reversible Scroll Heat Pumps
Style A***

Cooling Capacities: 115 Tons to 170 Tons
Cooling Capacities: 400 kW to 600 kW
Heating Capacities: 1390 MBH to 2040 MBH
Heating Capacities: 400 kW to 600 kW
60Hz
HFC-410A



Products are produced at a facility whose quality management systems are ISO9001 certified.



Introduction

CONTENTS

Introduction..... 2
 Product Description 3
 Microcomputer Control Center 4
 Accessories and Options 5
 Refrigerant Flow Block Diagrams 6
 Component Location..... 7
 Application Data 8
 Connection Diagram 14
 Water Pressure Drop..... 15
 Ratings 16
 Technical Data 19
 Dimensions 21

NOMINAL DATA

YLPA Model		0115SE	0145SE	0170SE
Cooling Mode ⁽¹⁾	Capacity (TONS)	118	146	167
	Capacity (kW)	414	515	587
Heating Mode ⁽²⁾	Capacity (MBH)	1390	1731	2037
	Capacity (kW)	412	510	612

(1) At 54/44°F chilled water temperatures and 95°F ambient.

(2) At 104/113°F hot water temperatures and 44°F ambient.

NOMENCLATURE

YLPA0115SE40XBA

1	2	3	4	5	6	7	8	9	10	11	12	13	14	15
BASE PRODUCT TYPE				NOMINAL CAPACITY				UNIT DESIGNATION	REFRIGERANT	VOLTAGE / STARTER			DESIGN / DEVELOPMENT LEVEL	
Y	L	P	A	#	#	#	#	S	E	4	0	X	B	A
: York : Scroll : Heat Pump : All Regions				kW 0115 0145 0170				: Standard Unit	: R-410A	: 380 / 3 / 60 : Direct on Line			: Design Series : Development Level	

Product Description

YLPA air-to-liquid reversible heat pumps are completely factory assembled with all interconnecting refrigerant piping and wiring ready for field installation. The unit is pressure tested, evacuated, and fully factory charged with refrigerant R410A and oil in each of the independent refrigerant circuits. After assembly, an operational test is performed with water flowing through the heat exchanger to ensure that each refrigerant circuit operates correctly.

The unit structure is manufactured from heavy-gauge, galvanized steel coated with baked-on powder paint (Champagne (RAL 7006, Munsell No. 9.8YR4.36/1.2)).

YLPA heat pumps are designed in accordance with NFPA 70 (National Electric Code), ASHRAE/ANSI 15 Safety code for mechanical refrigeration, ASME and rated in accordance with ARI Standard 550/590.

COMPRESSORS

The unit has suction-cooled, hermetic scroll compressors. High efficiency is achieved through a controlled orbit and the use of advanced scroll geometry. The compressors incorporate a compliant scroll design in both the axial and radial directions. All rotating parts are statically and dynamically balanced. The compressor motors have integral protection against overloads that will automatically reset. Starting is direct on line, and soft start is available as an option.

The compressors are switched On and Off by the unit microprocessor to provide capacity control. Each compressor is fitted with a crankcase strap heater. All compressors are mounted on isolator pads to reduce transmission of vibration to the rest of the unit.

The motor terminal boxes have IP54 weather protection.

REFRIGERANT CIRCUITS

Two independent refrigerant circuits are provided on each unit. Each circuit uses copper refrigerant pipe formed on computer controlled bending machines to reduce the number of brazed joints resulting in a high integrity and reliable system.

Each circuit shall incorporate all components necessary for the designed operation including: a suction accumulator; a liquid receiver; a four way reversing valve which changes the direction of the refrigerant flow and the function of the heat exchanger when switching between cooling and heating modes; service valves; isolation (ball/angle) valves; pressure relief valves; a high absorption removable core filter-drier; a sight glass with moisture indicator; a cooling mode thermal expansion valve and a heat pump mode thermal expansion valve. Suction lines shall be covered with closed-cell insulation.

REFRIGERANT TO WATER HEAT EXCHANGER

The 2-pass dual circuit shell and tube type direct expansion (DX) heat exchanger has refrigerant in the tubes and liquid flowing through the baffled shell. The waterside (shell) design working pressure is 10 barg. The refrigerant side (tubes) design working pressure is 45 barg. The refrigerant side is protected by pressure relief valve(s).

The heat exchanger is equipped with a heater for frost protection to -4°F (below this the ball valve in the discharge line must be closed) and insulated with flexible closed-cell foam. Water connection to the heat exchanger is via victaulic grooved connections. Victaulic groove to flange converters are available as an option

AMBIENT COILS

The ambient coils are seamless copper tubes, arranged in staggered rows, mechanically expanded into coated aluminium fins. Integral sub-cooling is included.

The condenser fans have composite metal/plastic `sickle` blades integrated into the rotor of an external rotor motor. They are designed for maximum efficiency and statically and dynamically balanced for vibration free operation. They are directly driven by independent motors, and positioned for vertical air discharge. The fan guards are constructed from heavy-gauge, corrosion resistant, coated steel.

The IP54 fan motors are the totally enclosed air-over type with permanently lubricated double-sealed ball bearings.

POWER AND CONTROL PANELS

All power and controls are contained in an IP 55 cabinet with hinged and gasket sealed outer doors. The power panel includes:

- Factory mounted non-fused disconnect switch with external red/yellow, lockable handle to enable connection of the unit power supply. The disconnect switch can be used to isolate the power for servicing and as a emergency stop.
- Factory mounted compressor contactors and compressor fuses provide short circuit protection. Overload protection for each compressor is provided by inherent motor winding temperature sensing and a trip module.
- Factory mounted fan contactors and fuses provide short circuit protection. Overload protection for each fan is provided by a inherent motor winding temperature device.
- Factory mounted control transformer to convert the unit supply voltage to 115 V - 1 Ø - 60 Hz for the control system.
- Control supply fuses and connections for a remote emergency stop device.

Microcomputer Control Center

The control panel includes:

- A Liquid Crystal Display (two display lines of twenty characters per line) with Light Emitting Diode backlighting for easy viewing
- A Colour coded 12-button keypad
- Customer terminal blocks for control inputs and liquid flow switch.

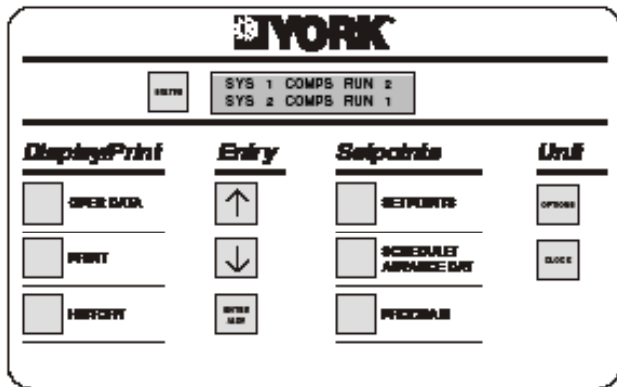

The microprocessor control includes:

- Automatic control of compressor start/stop, anticoincidence and anti-recycle timers, pump and unit alarm contacts. Automatic reset to normal unit operation after power failure.
- Remote water temperature setpoint reset via analog input or a pulse width modulated (PWM) input signal or up to two steps of demand (load) limiting.
- Software is loaded into the microprocessor controller via a SD card, with programmed setpoints retained in a lithium battery backed real time clock (RTC) memory.
- Forty character liquid crystal display, with description available in five languages (English, French, German, Spanish or Italian)

Programmable setpoints:

- Chilled liquid temperature setpoint and range
- Hot liquid temperature setpoint and range
- Remote reset temperature range
- Set daily schedule/holiday for start/stop
- Manual override for servicing
- Low ambient cutout
- High ambient cutout (heating only - fixed)
- Low liquid temperature cutout
- Low suction pressure cutout
- High discharge pressure cutout
- Anti-recycle timer (compressor start cycle time)
- Anti-coincident timer (delay compressor starts)

Displayed Data:

- Leaving liquid temperature
- Air coil defrost temperatures
- Low leaving liquid temperature cutout setting
- Low ambient temperature cutout setting
- Ambient air temperature
- Metric or Imperial data
- Discharge and suction pressure cutout settings
- System discharge and suction pressures
- Anti-recycle timer status for each system
- Anti-coincident system start timer condition
- Compressor run status
- No load condition
- Day, date and time
- Daily start/stop times
- Holiday status
- Automatic or manual system lead/lag control
- Lead system definition
- Compressor starts & operating hours (each compressor)
- Status of evaporator heater and fan operation
- Run permissive status
- Number of compressors running
- Mode solenoid valve status
- Load & unload timer status
- Liquid pump status

System Safeties:

- Cause individual compressors to perform auto shut down and require manual reset in the event of 3 trips in a 90-minute time period
- High discharge pressure
- Low suction pressure
- High-pressure switches
- Motor protector

Unit Safeties:

They are automatic reset and cause compressor to shut down

- Low leaving chilled liquid temperature
- Under voltage
- Loss of liquid flow (through flow switch)

For each system a common alarm contact for:

- Low leaving chilled liquid temperature
- Low voltage
- Low battery
- High discharge pressure (per system)
- Low suction pressure (per system)
- Compressor motor protection

Accessories and Options

FLOW SWITCH - The flow switch or its equivalent must be furnished with each unit. 150 psig (10.5 bar) DWP - For standard units. Johnson Controls model F61MG-1C Vapor-proof SPDT, NEMA 3R switch (150 PSIG [10.5 bar] DWP), -20°F to 250°F (-29°C to 121°C), with 1" NPT connection for upright mounting in horizontal pipe. (Field-mounted)

CHICAGO CODE RELIEF VALVES - Unit will be provided with relief valves to meet Chicago code requirements. (Factory-Mounted)

NEOPRENE PADS ISOLATORS - Recommended for normal installations (Field mounted)

1" SPRING ISOLATORS - Level adjustable, spring and cage type isolators for mounting under the unit base rails (Field mounted).

2" SPRING ISOLATORS - Restrained Spring-Flex Mountings incorporating a rugged welded steel housing with vertical and horizontal limit stops. (Field mounted).

FLANGE KIT - Provides contractor with the couplings best suited to tie into the chilled water piping. All flanges are PN10.

SINGLE-POINT SUPPLY TERMINAL BLOCK - Includes enclosure, terminal-block and interconnecting wiring to the compressors. Separate external protection must be supplied, by others, in the incoming compressor-power wiring. (Do not include this option if either the Single-Point Non-Fused Disconnect Switch or Single-Point Circuit Breaker options have been included.)

SINGLE-POINT CIRCUIT BREAKER - A unit mounted circuit breaker with external, lockable handle (in compliance with N.E.C. Article 440-14), can be supplied to isolate the power voltage for servicing. (This option includes the Single-Point Power connection.)

Refrigerant Flow Block Diagrams

COOLING MODE

Low pressure liquid refrigerant enters the heat exchanger and is evaporated and superheated by the heat energy absorbed from the chilled liquid. Low pressure vapor enters the compressor, via the four-way reversing valve and accumulator, where pressure and superheat are increased. The high pressure vapor is fed to the ambient coils and fans - via the four way reversing valve which changes the direction of the refrigerant flow and the function of the heat exchanger to cooling mode - where heat is removed. The fully condensed and subcooled liquid passes through the expansion valve (cooling) where pressure is reduced and further cooling takes place before returning to the heat exchanger.

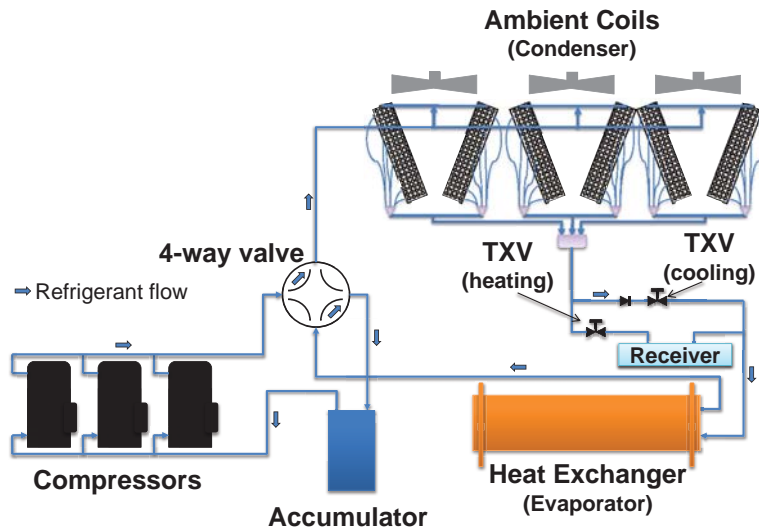

HEATING MODE

Liquid refrigerant enters the ambient coil and is fully evaporated and superheated by the energy absorbed from the ambient air. Low-pressure superheated refrigerant vapor passes through the four-way reversing valve - which changes the direction of the refrigerant flow and the function of the heat exchanger to heating mode - and the accumulator and enters the compressor, where pressure and superheat are increased. High-pressure superheated refrigerant vapor enters the refrigerant to water plate heat exchanger where heat is rejected to the water. The high-pressure liquid refrigerant, leaving the heat exchanger passes through the liquid receiver and enters thermostatic expansion valve (heating) where the refrigerant and subsequently cooled before returning to the ambient coil.

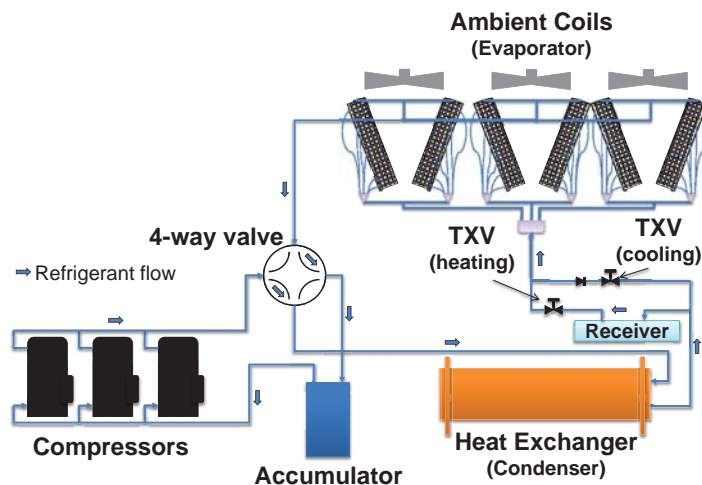

Defrost Operation

When ice builds up on the ambient coils defrost is initiated by operating the machine in a cooling mode. Each of the two refrigerant circuits will be defrosted one at a time. When defrost is operative the circuit operating in heating mode is in balance with the circuit operating in defrost (cooling). Therefore, heat energy is not removed from the hot water system.

Component Location

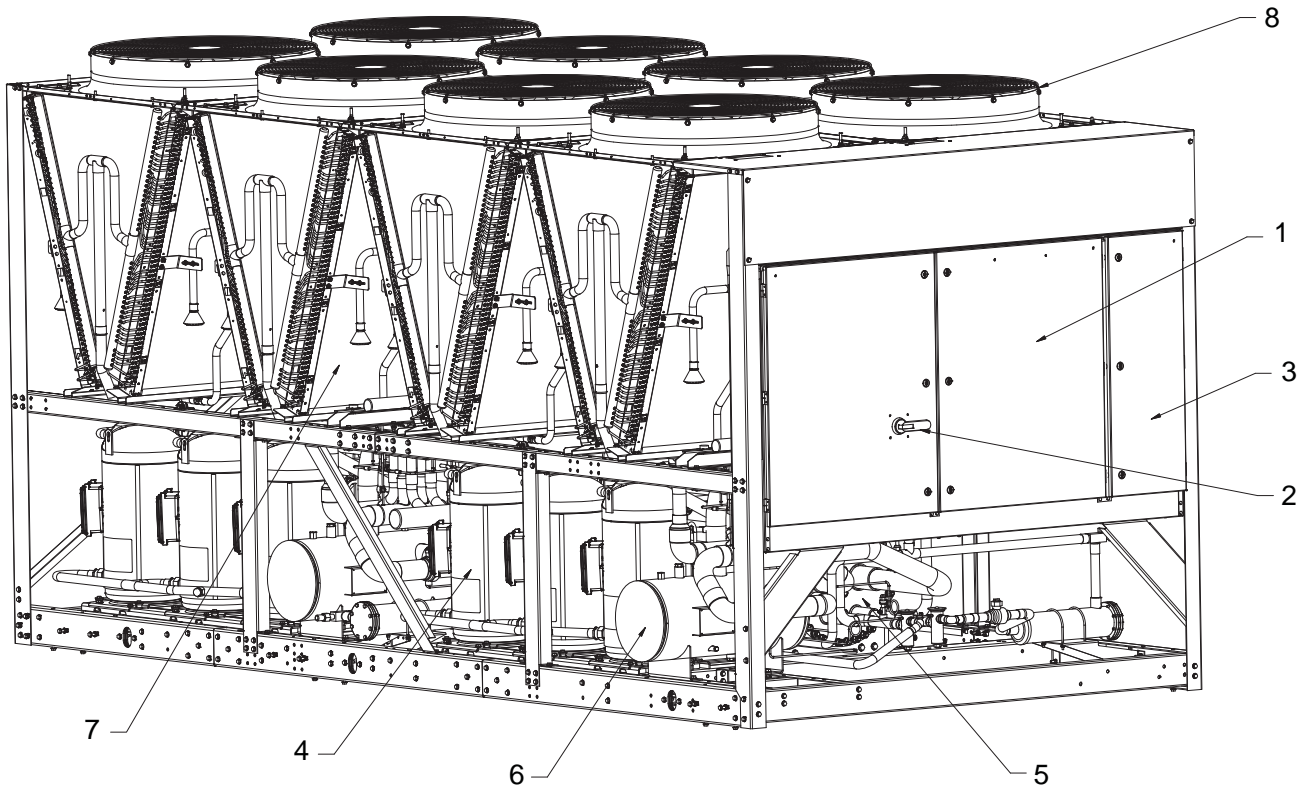

- 1 Power Panel
- 2 Non-Fused Disconnect Switch
- 3 Control Panel
- 4 Compressors
- 5 Heat Exchanger
- 6 Suction Accumulator
- 7 Ambient Coils
- 8 Fans

WEIGHTS AND WEIGHT DISTRIBUTION

The weights and weight distribution are given below:

Model	Weight (lbs)		Point Weight (lbs)							
	Shipping	Operating	R1	R2	R3	R4	L1	L2	L3	L4
0115SE	9811	10472	1864	1026	1414		2178	1822	2168	
0145SE	11243	11904	1021	1471	1024	1356	1595	2191	1541	1705
0170SE	12124	13447	1068	1545	1642	1279	1595	2257	2479	1582

	L1	L2	L3	L4
Control Panel				
	R1	R2	R3	R4

Application Data

LOCATION REQUIREMENTS

To achieve optimum performance and trouble-free service, it is essential that the proposed installation site meet with the location and space requirements for the model being installed.

The clearances recommended are nominal for the safe and efficient operation and maintenance of the unit and power and control panels. Local Health and safety regulations, or practical considerations for service replacement of large components, may require larger clearances than those given in this manual.

OUTDOOR INSTALLATIONS

The units can be installed at ground level on a suitable at level foundation easily capable of supporting the weight of the unit, or on a suitable rooftop location. In both cases an adequate supply of air is required. Avoid locations where the sound output and air discharge from the unit may be objectionable.

The location should be selected for minimum sun exposure and away from boiler flues and other sources of airborne chemicals that could attack the condenser coils and steel parts of the unit.

If located in an area accessible to unauthorized persons, steps must be taken to prevent access to the unit by means of a protective fence. This will help to prevent the possibility of vandalism, accidental damage, or possible harm caused by unauthorized removal of protective guards or opening panels to expose rotating or electrically live components.

For ground level locations, the unit must be installed on a suitable flat and level concrete base that extends to fully support the two side channels of the unit base frame. A one-piece concrete slab, with footings extending below the frost line is recommended. To avoid noise and vibration transmission, the unit should not be secured to the building foundation.

On rooftop locations, choose a place with adequate structural strength to safely support the entire operating weight of the unit and service personnel. The unit can be mounted on a concrete slab, similar to ground floor locations, or on steel channels of suitable strength. The channels should be spaced with the same centres as the unit side and front base rails. This will allow vibration isolators to be fitted if required. Isolators are recommended for rooftop locations.

LOCATION CLEARANCES

Adequate clearances around the unit(s) are required for the unrestricted air-flow for the ambient coils and to prevent re-circulation of discharge air back onto the coils. If clearances given are not maintained, air-flow restriction or re-circulation will cause a loss of unit performance, an increase in power consumption, and may cause the unit to malfunction. Consideration should also be given to the possibility of down drafts, caused by adjacent buildings, which may cause re-circulation or uneven unit air-flow.

For locations where significant cross winds are expected, such as exposed roof tops, an enclosure of solid or louvre type is recommended to prevent wind turbulence interfering with the unit air-flow.

When units are installed in an enclosure, the enclosure height should not exceed the height of the unit on more than one side. Where accumulation of snow is likely, additional height must be provided under the unit to ensure normal air-flow to the unit.

Refer to the table below and the diagrams on the following page for location clearances.

	Dim. (in)	YLPA		
		0115SE	0145SE	0170SE
Arrangement A1 Solid Walls	A	47	47	47
	B	32	32	32
	C	32	39	47
	D	55	55	55
Arrangement A2 Solid Walls	A	47	47	47
	B	32	32	32
	C	32	39	47
	D	106	126	126
	E	55	55	55
Arrangement A3 Louvres on 2 walls	A	47	47	47
	B	32	32	32
	C	32	39	47
	D	91	118	126
	E	55	55	55
Arrangement A4 Solid Walls	A	47	47	47
	B	47	47	47
	C	32	32	32
	D	32	39	47
	E	67	75	83
Arrangement A5 Louvres on 2 walls	A	47	47	47
	B	47	47	47
	C	32	32	32
	D	32	32	32
	E	55	55	55

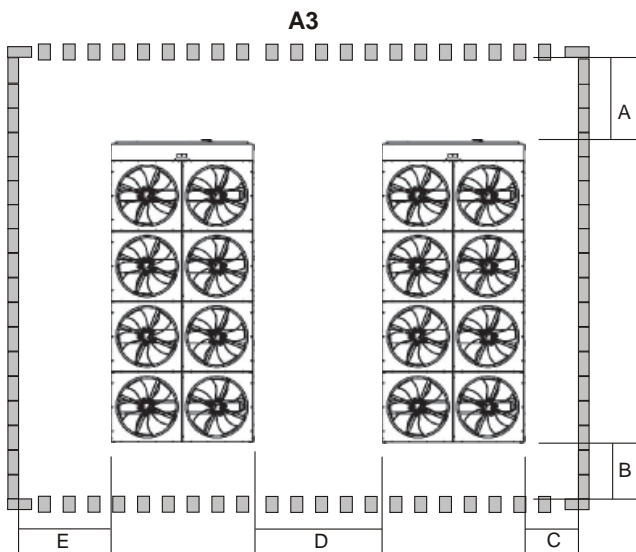
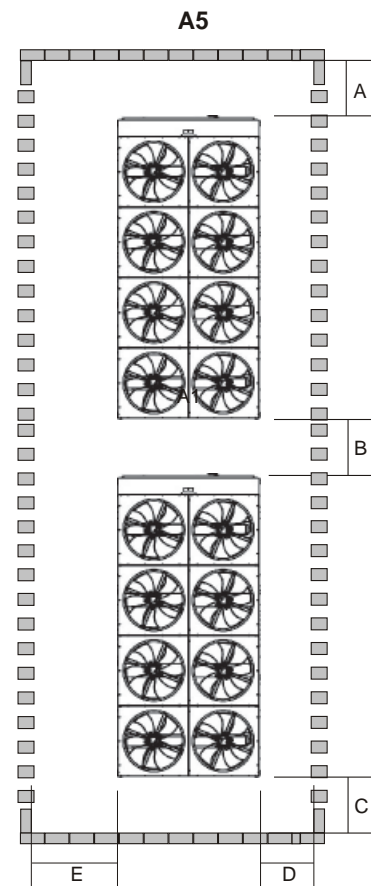
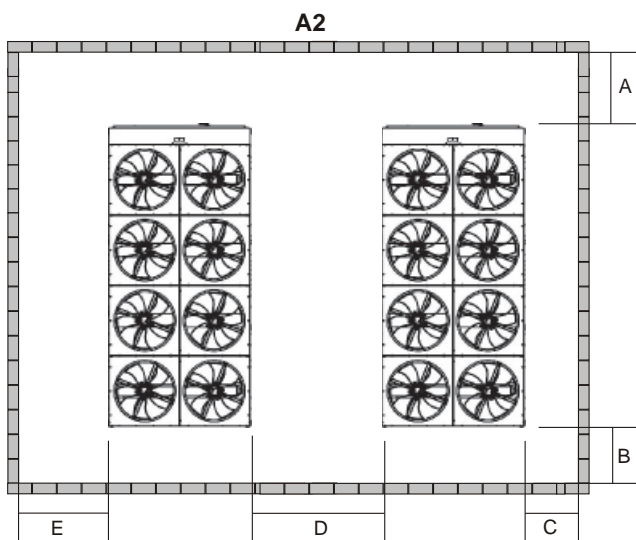
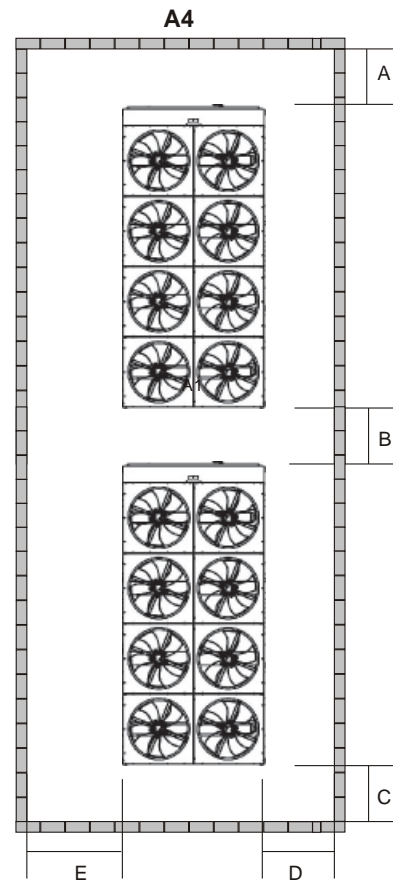
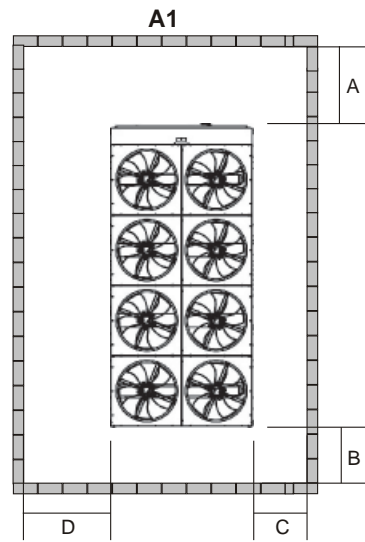

Application Data - continued

INSTALLATION OF VIBRATION ISOLATORS

An optional set of vibration isolators can be supplied loose with each unit.

PIPEWORK CONNECTION

The following piping recommendations are intended to ensure satisfactory operation of the unit. Failure to follow these recommendations could cause damage to the unit, or loss of performance, and may invalidate the warranty.

A flow switch must be installed in the customer pipework at the outlet of the heat exchanger as shown in the arrangement diagrams, and wired back to the control panel using screened cable. This is to prevent damage to the heat exchanger caused by inadequate liquid flow. To prevent turbulent flow, there must be straight pipework either side of the flow switch equal in length to at least 5 times the diameter of the pipe.

The flow switches used must have gold plated contacts for low voltage/current operation

Alternatively, a differential pressure switch fitted across an orifice plate may be used, preferably of the high/low limit type.

The liquid pumps installed in the pipework systems should discharge directly into the unit heat exchanger sections of the system. The pumps require an auto-starter (by others) to be wired to the control panel.

Pipework and fittings must be separately supported to prevent any loading on the heat exchanger(s). Flexible connections are recommended which will also minimize transmission of vibrations to the building. Flexible connections must be used if the unit is mounted on anti-vibration mounts as some movement of the unit can be expected in normal operation.

Pipework and fittings immediately next to the heat exchanger(s) should be readily demountable to enable cleaning prior to operation, and to facilitate visual inspection of the exchanger nozzles.

Each heat exchanger must be protected by a strainer, preferably of 20 mesh, fitted as close as possible to the liquid inlet connection, and provided with a means of local isolation.

The heat exchanger(s) must not be exposed to flushing velocities or debris released during flushing. It is recommended that a suitably sized by-pass and valve arrangement be installed to allow flushing of the pipework system. The by-pass can be used during maintenance to isolate the heat exchanger(s) without disrupting flow to other units.

Thermometer and pressure gauge connections should be provided on the inlet and outlet connections of each heat exchanger.

Drain and air vent connections should be provided at all low and high points in the pipework to permit drainage of the system, and to vent any air in the pipes.

Liquid systems at risk of freezing, due to low ambient temperatures, should be protected using insulation and heater tape and/or a suitable glycol solution. The liquid pumps must also be used to ensure liquid is circulated when the ambient temperature approaches freezing point. Insulation should also be installed around the heat exchanger nozzles.

Heater tape under the insulation is recommended, supplied independently and controlled by an ambient temperature thermostat set to switch on at approximately 4°F above the freezing temperature of the chilled liquid.

The heat exchanger is protected by a heater mat placed under the insulation, which are powered from the unit control system power supply. During cold weather when there is a risk of freezing, chiller power should be left switched on to provide the freeze protection function unless the liquid systems have been drained.

PIPEWORK ARRANGEMENT

The following are suggested pipework arrangements for single unit installations. For multiple unit installations, each unit should be piped as shown. These are recommendations of the Building Services Research Association.

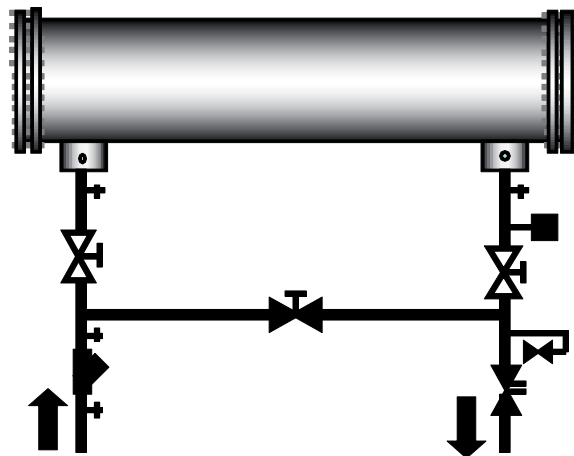

- Pressure Tapping
- Air vent
- Flow Switch
- Isolating Valve – Normally Open
- Isolating Valve – Normally Closed
- Flow Regulating Valve
- Strainer

CONNECTION TYPES AND SIZES

Standard pipework connections are of the Victaulic groove type.

For connection sizes relevant to individual models refer to the physical data tables in this manual.

WATER TREATMENT

The unit performance given in the Design Guide is based on a fouling factor of 0.0001 ft²hr°F/Btu. Dirt, scale, grease and certain types of water treatment will adversely affect the heat exchanger surfaces and therefore unit performance. Foreign matter in the water system(s) can increase the pressure drop, reducing the flow rate and causing potential damage.

Aerated, brackish or salt water is not recommended for use in the water systems. JCI recommends that a water

treatment specialist be consulted to determine whether the proposed water composition will not affect the heat exchanger materials of carbon steel and copper. The pH value of the water flowing through the unit must be kept between 7 and 8.5.

WATER QUALITY REQUIREMENTS

The water used in the unit liquid system must meet the requirements detailed in the table below:

Item	Unit	Allowable Value	Potential Problem	
			Corrosion	Fouling
pH (25°C)	pH	7.0 to 8.5	■	
SO ⁴	ppm	<100	■	
HCO ³ /SO ⁴	ppm	>1.0	■	
Cl	ppm	<50	■	
PO ⁴	ppm	<2.0	■	
NH ³	ppm	<0.5	■	
Free Cl	ppm	<0.5	■	
Fe+++	ppm	<0.5	■	
Mn++	ppm	<0.05	■	
CO ²	ppm	<10	■	
H ² S	ppm	<50	■	
Temp	°C	<65	■	■
O content	ppm	<0.1	■	
Hardness	dH	4.8 to 8.5		■



Water quality should be inspected before unit installation and regularly during unit operation. The water quality must meet the limits above. If parameters are not within limits, the heat exchanger may leak or have problems within scale formation. These problems may result in the unit not operating normally, excessive heat exchanger pressure drops and reduced nominal capacities.

REFRIGERANT RELIEF VALVE PIPING

The heat exchanger is protected against internal refrigerant overpressure by refrigerant relief valves. A pressure relief valve is mounted on each of the main refrigerant lines connecting the evaporator to the compressors. For indoor installations, pressure relief valves should be piped to the exterior of the building.

The size of any pipework attached to a relief valve must be of sufficient diameter so as not to cause resistance to the operation of the valve. The internal diameter depends on the length of pipe required and must be in accordance with local regulations.

If relief pipework is common to more than one valve its cross sectional area must be at least the total required by each valve. Valve types should not be mixed on a common pipe. Precautions should be taken to ensure that the exit of relief valves/vent pipe remain clear of obstructions at all times.

Application Data - continued

ELECTRICAL CONNECTION

The following connection recommendations are intended to ensure safe and satisfactory operation of the unit. Failure to follow these recommendations could cause harm to persons, or damage to the unit, and may invalidate the warranty.

No additional controls (relays, etc.) should be mounted in the control panel. Power and control wiring not connected to the control panel should not be run through the control panel. If these precautions are not followed it could lead to a risk of electrocution. In addition, electrical noise could cause malfunctions or damage the unit and its controls.

POWER WIRING

These units are suitable for 460 V, 3-phase, 60Hz nominal supplies only.

All electrical wiring should be carried out in accordance with local regulations. Route properly sized cables to the cable entries in the bottom of the power panel.

It is the responsibility of the user to install over current protection devices between the supply conductors and the power supply terminals on the unit.

To ensure that no eddy currents are set up in the power panel, the cables forming each 3 phase power supply must enter via the same cable entry.

All sources of supply to the unit must be taken via a common point of isolation (not supplied by JCI).

SINGLE POINT POWER SUPPLY WIRING

All models require one field provided 460 V, 3Ø, 60 Hz + PE (Protected Earth) supply to the unit with circuit protection.

Connect the 3-phase supply to the non-fused disconnect switch located in the power panel using M12 lugs.

Connect the earth wire to the main protective earth terminal located in the power panel using a M10 lug.

CONTROL CIRCUIT TRANSFORMER

The control circuit transformer providing the 115 V, 1Ø, 50Hz supply to the unit control system is fitted in a separate enclosure.

REMOTE EMERGENCY STOP DEVICE

If required, a remote emergency stop device may be wired into the unit. This device should be rated at 20 amps, 115V, AC-15. The device should be wired into terminals L and 5 in the power panel after removing the factory fitted link.

CONTROL WIRING - VOLTAGE FREE CONTACT

All wiring to the voltage free contact terminal block requires a supply provided by the customer maximum voltage 115Vac, 24 Vdc.

The customer must take particular care deriving the supplies for the voltage free terminals with regard to a common point of isolation. Thus, these circuits when used must be fed via the common point of isolation so the voltage to these circuits is removed when the common point of isolation to the unit is opened. This common point of isolation is not supplied by JCI.

It is recommended that the customer wiring to these terminals uses orange wires. This will ensure that circuits not switched off by the units supply disconnecting device are distinguished by colour, so that they can easily be identified as live even when the unit disconnecting devices are off. The YORK voltage free contacts are rated at 125 VA.

All inductive devices (relays) switched by the YORK voltage free contacts must have their coil suppressed using standard RC suppressors. If these precautions are not followed, electrical noise could cause malfunctions or damage to the unit and its controls.

Chilled Liquid Pump Starter

Terminals 23 and 24 close to start the liquid pump. This contact is closed if there is a 'Leaving Liquid Temperature Cutout' or any of the compressors are running or the daily schedule is not calling for a shutdown with the unit switch on.

The contact must be used to ensure that the pump is running in the event of a 'Leaving Liquid Temperature Cutout'.

The pump contact will not close to run the pump if the unit has been powered up for less than 30 seconds, or if the pump has run in the last 30 seconds, to prevent pump motor overheating.

Run Contacts

Terminals 25 and 26 close to indicate that refrigerant system 1 is running and terminals 27 and 28 close to indicate that refrigerant system 2 is running.

Alarm Contacts

Each refrigerant system has a voltage-free normally open contact that will close when control power is applied to the panel, if no fault conditions are present. When a fault occurs which locks a system out, or there is a power failure the contact opens. To obtain a system alarm signal, connect the alarm circuit to terminals 29 and 30 for No. 1 system and terminals 31 and 32 for No. 2 system.

Control Wiring - System Inputs

All wiring to the control terminal block (nominal 30 Vdc) must be run in screened cable, with the screen earthed at the panel end only. Run screened cable separately from mains cable to avoid electrical noise pick-up.

The voltage free contacts must be suitable for 30 Vdc (gold contacts recommended). If the voltage free contacts form part of a relay or contactor, the coil of the device must be suppressed using a standard RC suppressor. The above precautions must be taken to avoid electrical noise that could cause a malfunction or damage to the unit and its controls.

Flow Switch

A chilled liquid flow switch of suitable type must be connected to terminals 13 and 14 to provide adequate protection against loss of liquid flow.

Remote Start/Stop

Connect a remote switch to terminals 13 and 51 to provide remote start/stop control if required.

Remote Mode Selection

Remote mode selection can be accomplished by connecting a contact between terminals 13 and 50. With the contact open the unit is in the cooling mode, with the contact closed the unit is in the heating mode.

Remote Reset of Chilled Liquid Setpoint

The PWM input (terminals 13 and 20) allows reset of the chilled liquid setpoint by supplying a 'timed' contact closure.

Remote Load Limiting

Load limiting prevents the unit from loading beyond a desired value. The unit % load limit depends on the number of compressors on the unit. The load limit inputs to terminals 13 and 21 work in conjunction with the PWM input to terminals 13 and 20.

Fan Full Speed Inhibit

To reduce unit noise the fans can be limited to run at a maximum speed of all fans in star (reduced speed) i.e. fan full speed is inhibited. Connect a customer voltage free contact to terminals 13 & 15.

EMS Analogue Input

Provides a means of resetting the leaving chilled or hot liquid temperature from the BAS/EMS. Accepts 4 to 20 mA, 0 to 20 mA, 0 to 10 Vdc or 2-10 Vdc. Connect to terminal A+ and A-.

Modbus, BACnet MS/TP and N2

Enable communications with building protocol systems using Modbus, BACnet or N2 protocol. Connect through standard RS485 port.

Connection Diagram

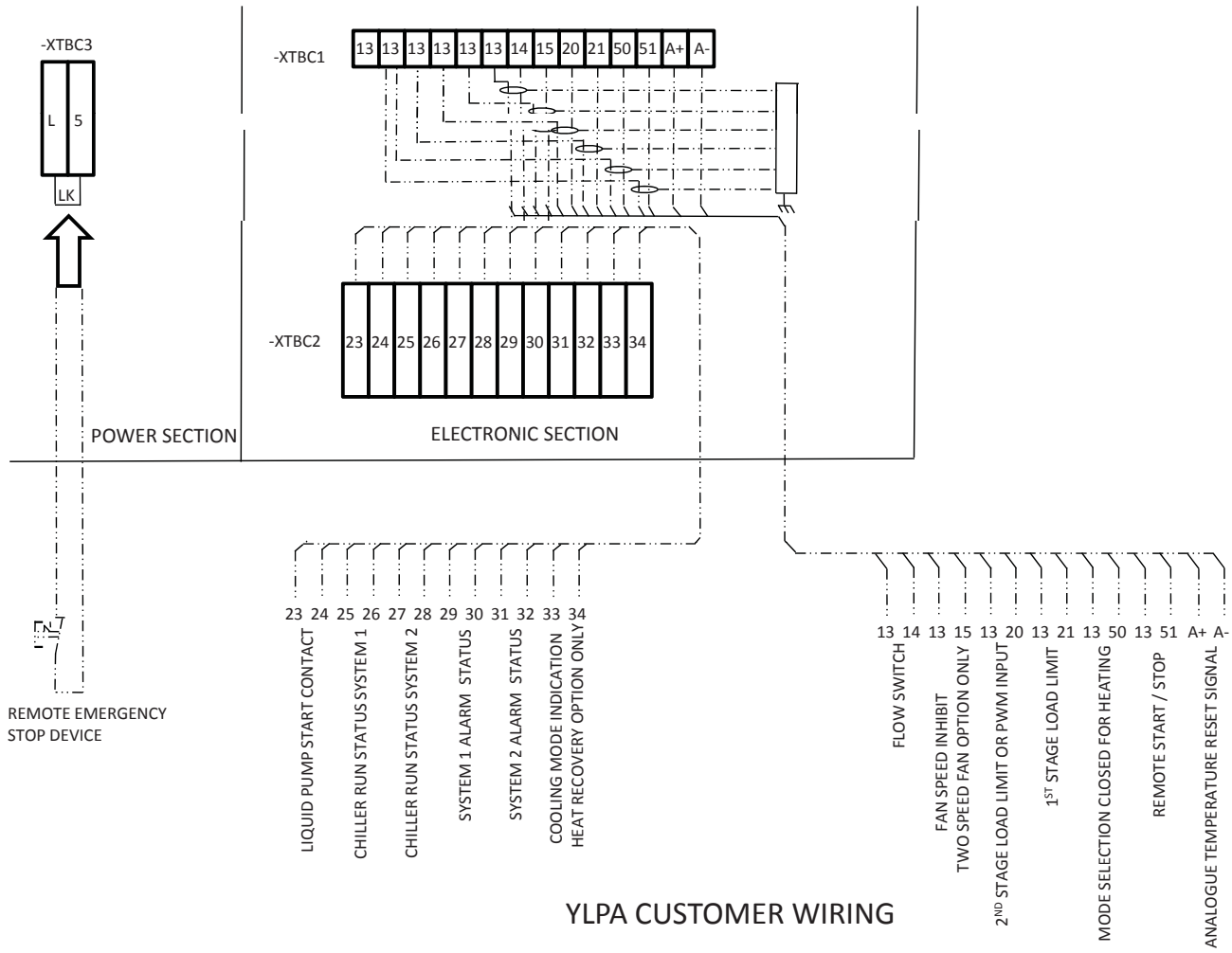

Water Pressure Drop

Refrigerant to Water Heat Exchanger Pressure Drop Graph

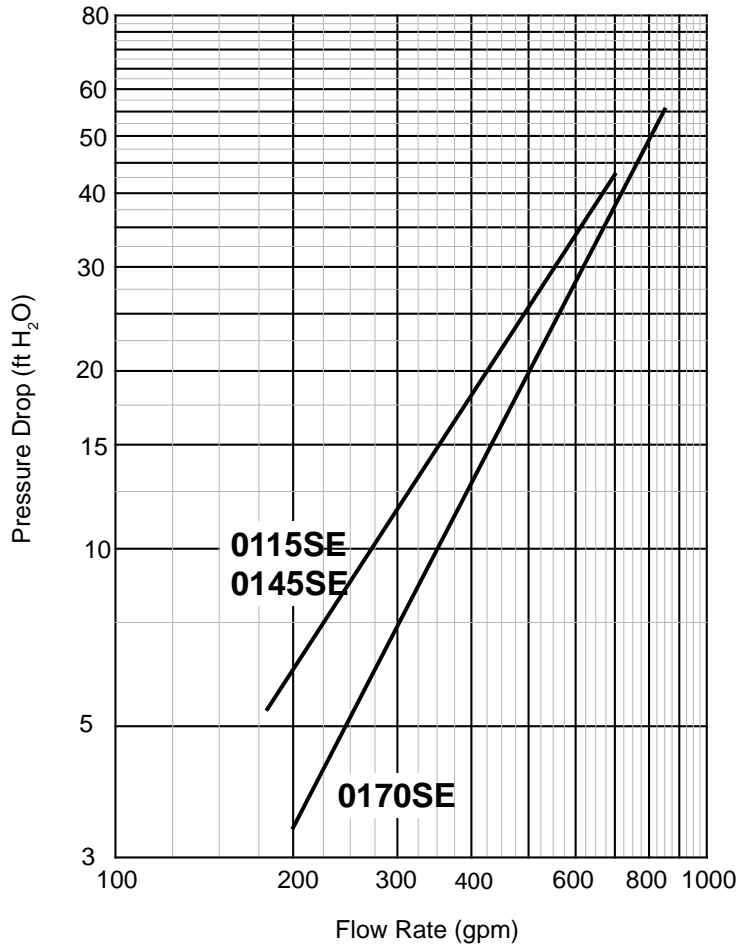

PERFORMANCE DATA - COOLING

Rated in accordance with AHRI Standard 550/590 based on sea level altitude, evaporator fouling factor of 0.0001°F-ft²/Btu, evaporator temperature drop of 10°F, and 2 pass evaporator configuration.

LCWT (°F)	YLPA MODEL	IPLV	AIR TEMPERATURE ON - CONDENSER (°F)														
			75			80			85			90			95		
			TONS	COMP KW	EER	TONS	COMP KW	EER	TONS	COMP KW	EER	TONS	COMP KW	EER	TONS	COMP KW	EER
40	115	14.6	124.2	101.2	13.0	120.8	106.3	12.1	117.4	111.7	11.2	113.8	117.6	10.4	110.2	123.8	9.6
	145	14.8	154.3	126.2	12.9	150.2	132.6	12.0	145.9	139.4	11.2	141.5	146.8	10.4	136.9	154.6	9.6
	170	14.2	175.7	150.6	12.3	171.0	158.2	11.5	166.2	166.5	10.7	161.3	175.3	9.9	156.2	184.7	9.1
42	115	14.6	128.3	102.2	13.3	124.9	107.3	12.4	121.3	112.8	11.5	117.7	118.6	10.7	113.9	124.9	9.9
	145	14.8	159.4	127.5	13.2	155.2	133.9	12.3	150.8	140.7	11.5	146.3	148.1	10.6	141.5	155.9	9.8
	170	14.2	181.6	152.0	12.6	176.8	159.7	11.8	171.8	168.0	10.9	166.7	176.8	10.1	161.5	186.2	9.4
44	115	14.6	132.5	103.3	13.6	129.0	108.4	12.7	125.3	113.9	11.8	121.5	119.7	10.9	117.7	126.0	10.1
	145	14.8	164.6	128.9	13.5	160.3	135.2	12.6	155.7	142.1	11.7	151.1	149.4	10.9	146.3	157.3	10.1
	170	14.2	187.5	153.6	12.9	182.6	161.2	12.1	177.5	169.5	11.2	172.2	178.3	10.4	166.8	187.8	9.6
45	115	14.6	134.6	103.9	13.8	131.1	108.9	12.8	127.3	114.4	11.9	123.5	120.3	11.1	119.6	126.6	10.2
	145	14.8	167.3	129.6	13.7	162.8	135.9	12.8	158.2	142.8	11.9	153.5	150.1	11.0	148.6	158.0	10.2
	170	14.2	190.5	154.3	13.1	185.5	162.0	12.2	180.3	170.3	11.3	175.0	179.1	10.5	169.5	188.6	9.7
46	115	14.6	136.8	104.5	13.9	133.1	109.5	13.0	129.4	115.0	12.1	125.5	120.9	11.2	121.5	127.1	10.4
	145	14.8	169.9	130.3	13.8	165.4	136.6	12.9	160.7	143.5	12.0	155.9	150.8	11.2	151.0	158.7	10.3
	170	14.2	193.6	155.1	13.2	188.5	162.8	12.3	183.2	171.1	11.5	177.8	179.9	10.7	172.2	189.4	9.9
48	115	14.6	141.1	105.6	14.2	137.4	110.7	13.3	133.5	116.2	12.3	129.5	122.0	11.5	125.4	128.3	10.6
	145	14.8	175.3	131.7	14.1	170.6	138.0	13.2	165.8	144.9	12.3	160.9	152.3	11.4	155.8	160.1	10.6
	170	14.2	199.7	156.8	13.5	194.5	164.4	12.6	189.1	172.7	11.7	183.5	181.6	10.9	177.8	191.1	10.1
50	115	14.6	145.5	106.8	14.5	141.7	111.9	13.6	137.7	117.4	12.6	133.5	123.2	11.7	129.3	129.5	10.8
	145	14.8	180.7	133.2	14.4	175.9	139.5	13.5	171.0	146.4	12.6	165.9	153.8	11.7	160.7	161.6	10.8
	170	14.2	205.9	158.5	13.8	200.6	166.1	12.9	195.0	174.4	12.0	189.2	183.3	11.1	183.3	192.8	10.3

LCWT (°F)	YLPA MODEL	IPLV	AIR TEMPERATURE ON - CONDENSER (°F)											
			100			105			110			115		
			TONS	COMP KW	EER	TONS	COMP KW	EER	TONS	COMP KW	EER	TONS	COMP KW	EER
40	115	14.6	106.4	130.5	8.9	102.5	137.5	8.1	98.4	144.9	7.5	94.3	152.7	6.8
	145	14.8	132.2	162.9	8.8	127.4	171.7	8.1	122.5	181.0	7.4	117.4	190.8	6.8
	170	14.2	150.9	194.8	8.4	145.5	205.4	7.7	140.0	216.6	7.1	134.2	228.5	6.5
42	115	14.6	110.0	131.6	9.1	106.0	138.6	8.4	101.9	146.0	7.7	97.6	153.9	7.0
	145	14.8	136.7	164.2	9.1	131.8	173.0	8.3	126.7	182.3	7.6	121.5	192.2	7.0
	170	14.2	156.0	196.3	8.6	150.5	207.0	7.9	144.8	218.2	7.3	138.9	230.1	6.7
44	115	14.6	113.7	132.7	9.3	109.6	139.7	8.6	105.4	147.2	7.9	101.0	155.0	7.2
	145	14.8	141.3	165.6	9.3	136.2	174.4	8.5	131.0	183.7	7.8	125.6	193.6	7.2
	170	14.2	161.2	197.9	8.9	155.5	208.5	8.2	149.6	219.8	7.5	143.6	231.7	6.8
45	115	14.6	115.5	133.2	9.4	111.4	140.3	8.7	107.1	147.8	8.0	102.7	155.6	7.3
	145	14.8	143.6	166.3	9.4	138.4	175.1	8.6	133.1	184.5	7.9	127.7	194.3	7.3
	170	14.2	163.9	198.7	9.0	158.1	209.4	8.3	152.1	220.6	7.6	146.0	232.5	6.9
46	115	14.6	117.4	133.8	9.6	113.2	140.9	8.8	108.9	148.4	8.1	104.4	156.2	7.4
	145	14.8	145.9	167.0	9.5	140.7	175.9	8.8	135.3	185.2	8.0	129.8	195.0	7.3
	170	14.2	166.5	199.5	9.1	160.6	210.2	8.4	154.6	221.5	7.7	148.4	233.4	7.0
48	115	14.6	121.1	135.0	9.8	116.8	142.1	9.0	112.4	149.6	8.3	107.9	157.5	7.6
	145	14.8	150.6	168.5	9.7	145.2	177.4	9.0	139.7	186.7	8.2	134.1	196.6	7.5
	170	14.2	171.8	201.2	9.3	165.8	211.9	8.6	159.6	223.2	7.9	153.3	235.1	7.2
50	115	14.6	124.9	136.2	10.0	120.5	143.3	9.2	116.0	150.8	8.5	111.3	158.7	7.8
	145	14.8	155.3	170.0	10.0	149.8	178.9	9.2	144.2	188.3	8.4	138.4	198.1	7.7
	170	14.2	177.3	202.9	9.5	171.1	213.6	8.8	164.7	224.9	8.1	158.2	236.9	7.4

NOTES:

1. COMP KW = Compressor Input Power
2. EER = Heat Pumps EER (includes power from compressors, fans, and the control panels 0.8 kW)
3. LCWT = Leaving Chilled Water Temperature
4. Ratings are based upon 2.4 GPM evaporator water per ton and 0.0001 fouling factor
5. Rated in accordance with ARI Standard 550/590

PERFORMANCE DATA - PART LOAD

Rated in accordance with AHRI Standard 550/590 based on sea level altitude, evaporator fouling factor of 0.0001°F-ft²h/Btu, evaporator temperature drop of 10°F, and 2 pass evaporator configuration.

YLPA 0115 SE				
% Displ.	Ambient °F	TONS	COMP KW	EER
100.0	117.7	126.0	95.0	10.1
75.0	95.6	81.3	83.8	12.1
50.0	67.5	47.2	69.4	15.0
25.0	34.7	20.5	55.0	17.4

YLPA 0115 SE	
% LOAD	EER
100.0	10.1
75.0	12.9
50.0	15.6
25.0	17.1
IPLV: 14.6	

YLPA 0145 SE				
% Displ.	Ambient °F	TONS	COMP KW	EER
100.0	146.3	157.3	95.0	10.1
80.0	126.6	112.2	86.9	11.8
60.0	100.0	73.6	76.0	13.8
40.0	68.5	44.1	63.1	16.2
20.0	34.5	20.2	55.0	17.5

YLPA 0145 SE	
% LOAD	EER
100.0	10.1
75.0	13.1
50.0	15.8
25.0	17.4
IPLV: 14.8	

YLPA 0170 SE				
% Displ.	Ambient °F	TONS	COMP KW	EER
100.0	166.8	187.8	95.0	9.6
83.3	147.8	142.0	88.2	10.9
66.7	126.8	101.4	80.6	12.5
50.0	98.4	68.2	70.4	14.1
33.3	66.3	41.9	58.8	16.3
16.7	32.8	20.1	55.0	16.7

YLPA 0170 SE	
% LOAD	EER
100.0	9.6
75.0	12.4
50.0	15.2
25.0	16.3
IPLV: 14.2	

Ratings - continued

PERFORMANCE DATA - HEATING

Rated in accordance with AHRI Standard 550/590 based on sea level altitude, evaporator fouling factor of 0.0001°F-ft²/Btu, evaporator temperature drop of 10°F, and 2 pass evaporator configuration.

LHWT (°F)	YLPA MODEL	AIR TEMPERATURE ON - CONDENSER (°F)											
		44			50			55			60		
		MBH	COMP KW	COP	MBH	COMP KW	COP	MBH	COMP KW	COP	MBH	COMP KW	COP
95	115	1419.5	118.8	3.5	1501.9	118.8	3.7	1567.0	118.9	3.9	1632.0	118.9	4.0
	145	1768.2	146.9	3.5	1871.0	147.0	3.7	1952.0	147.0	3.9	2033.0	147.0	4.1
	170	2081.1	176.3	3.5	2202.0	176.4	3.7	2297.3	176.5	3.8	2392.7	176.5	4.0
100	115	1411.1	125.3	3.3	1494.4	125.5	3.5	1561.1	125.6	3.6	1627.7	125.7	3.8
	145	1757.8	154.9	3.3	1861.6	155.2	3.5	1944.6	155.3	3.7	2027.6	155.4	3.8
	170	2068.8	186.0	3.3	2191.0	186.3	3.4	2288.7	186.4	3.6	2386.3	186.6	3.7
105	115	1402.7	131.8	3.1	1486.9	132.1	3.3	1555.1	132.3	3.4	1623.4	132.5	3.6
	145	1747.4	163.0	3.1	1852.3	163.4	3.3	1937.2	163.6	3.5	2022.2	163.8	3.6
	170	2056.5	195.7	3.1	2180.0	196.2	3.3	2280.0	196.4	3.4	2380.0	196.7	3.5
110	115	1394.4	138.3	3.0	1479.4	138.8	3.1	1549.2	139.0	3.3	1619.0	139.3	3.4
	145	1736.9	171.0	3.0	1842.9	171.6	3.1	1929.9	171.9	3.3	2016.8	172.2	3.4
	170	2044.3	205.3	2.9	2169.0	206.0	3.1	2271.3	206.4	3.2	2373.7	206.7	3.4
113	115	1389.3	142.2	2.9	1474.9	142.8	3.0	1545.7	143.1	3.2	1616.4	143.3	3.3
	145	1730.7	175.9	2.9	1837.3	176.5	3.0	1925.4	176.9	3.2	2013.6	177.2	3.3
	170	2036.9	211.1	2.8	2162.4	211.9	3.0	2266.1	212.3	3.1	2369.9	212.8	3.3
115	115	1386.0	144.8	2.8	1471.9	145.4	3.0	1543.3	145.7	3.1	1614.7	146.0	3.2
	145	1726.5	179.1	2.8	1833.6	179.8	3.0	1922.5	180.2	3.1	2011.4	180.6	3.3
	170	2032.0	215.0	2.8	2158.0	215.9	2.9	2262.7	216.3	3.1	2367.3	216.8	3.2
120	115	1375.9	151.5	2.7	1464.4	152.1	2.8	1537.4	152.5	3.0	1610.4	152.8	3.1
	145	1713.9	187.3	2.7	1824.2	188.0	2.8	1915.1	188.5	3.0	2006.0	189.0	3.1
	170	2017.2	224.8	2.6	2147.0	225.8	2.8	2254.0	226.3	2.9	2361.0	226.9	3.0
125	115	1364.2	160.8	2.5	1453.7	161.6	2.6	1527.5	161.8	2.8	1601.4	162.1	2.9
	145	1699.4	198.8	2.5	1810.8	199.8	2.7	1902.8	200.1	2.8	1994.8	200.4	2.9
	170	2000.1	238.6	2.5	2131.3	239.9	2.6	2239.5	240.2	2.7	2347.8	240.6	2.9
130	115	1352.6	170.1	2.3	1442.9	171.1	2.5	1517.6	171.2	2.6	1592.3	171.3	2.7
	145	1684.9	210.3	2.3	1797.5	211.5	2.5	1890.5	211.7	2.6	1983.5	211.8	2.7
	170	1983.0	252.4	2.3	2115.5	254.0	2.4	2225.0	254.1	2.6	2334.5	254.3	2.7

NOTES:

1. COMP kW = Compressor Input Power
2. COP = Heat Pumps COP (includes power from compressors, fans, and the control panels 0.8 kW)
3. LHWT = Leaving Hot Water Temperature

OPERATING LIMITATIONS

YLPA			0115SE		0145SE		0170SE	
			Min.	Max.	Min.	Max.	Min.	Max.
Cooling Mode	Liquid Outlet Temperature (Water)	°F	39 to 59					
	Liquid Outlet Temperature Range (ΔT)	°F	6 to 15					
	Air Temperature - Standard Unit	°F	32 to 115 ⁽¹⁾					
Heating Mode	Liquid Outlet Temperature (Water)	°F	95 to 131					
	Liquid Outlet Temperature Range (ΔT)	°F	6 to 15					
	Air Temperature - Standard Unit	°F	14 to 95					
Heat Exchanger Flow Rate	gpm	181	700	181	700	200	850	
Heat Exchanger Pressure Drop	ftH ₂ O	5.4	43.0	5.4	43.0	3.4	55.4	
Maximum Water Side Pressure	psi	150						
Maximum Refrigerant Side Pressure	psi	650						
Power Supply Voltage ⁽²⁾	V	200V 3Ø, 60Hz (nominal) 230V 3Ø, 60Hz (nominal) 380V 3Ø, 60Hz (nominal) 460V 3Ø, 60Hz (nominal) 575V 3Ø, 60Hz (nominal)						

(1) Unit may operate unloaded up to 125°F depending on model size and site conditions.

(2) Tolerance +/-10%

PHYSICAL DATA

YLPA			0115SE	0145SE	0170SE
Number of refrigerant circuits			2		
Refrigerant Charge ⁽¹⁾	System 1 / System 2	lb	130 / 137	181 / 132	181 / 181
Oil Charge	System 1 / System 2	lb	24.2 / 24.2	37.4 / 24.2	37.4 / 37.4
Compressor	Number of compressors		2 / 2	3 / 2	3 / 3
	Type		Scroll		
Refrigerant to Liquid Heat Exchanger	Number		1		
	Type		Shell and Tubes		
	Water Volume	l	300		600
	Water Connections	inch	8		
Ambient Coils Fans	Number of Fans (circuit 1 / circuit 2)		4 / 4	6 / 4	6 / 6
	Total Air Flow - Standard Models	m ³ /s	47	58	70
Dimensions	Length	inch	194.4	230.5	274.4
	Width	inch	88.4	88.4	88.4
	Height	inch	94.1	94.1	94.1
Basic Unit Weight	Shipping Weight	lb	9811	11243	12124
	Operating Weight	lb	10472	11904	13447

(1) Liquid sub-cooling measured at the liquid line should be between 47.3 and 52.0°F at circuit full load. Sub-cooling is determined by the level of refrigerant charge in each system

Technical Data - continued

ELECTRICAL DATA

YLPA		0115SE	0145SE	0170SE
Unit Power Supply	V - Ø - Hz	460 - 3 - 60	460 - 3 - 60	460 - 3 - 60
Voltage Limits	(V)	414 - 506	414 - 506	414 - 506
Min. Circuit Ampacity	(A)	264	326	487
Max. Dual Element Fuse Size	(A)	300	350	600
Max. Circuit Breaker Size	(A)	300	350	600
Number of Compressors (System 1 / System 2)		2 / 2	3 / 2	3 / 3
Compressor RLA (each compressor)	(A)	54.5	54.5	54.5
Compressor LRA (each compressor)	(A)	310	310	310
Compressor Heater Supply	V - Ø - Hz	115 - 1 - 60	115 - 1 - 60	115 - 1 - 60
Compressor Heater Load	(W)	600	750	900
Number of Fans (System 1 / System 2)		4 / 4	6 / 4	6 / 6
Fan FLA (each fan)	(A)	4	4	4
Fan LRA (each fan)	(A)	19	19	19
Evaporator Heater Supply	V - Ø - Hz	115 - 1 60	115 - 1 60	115 - 1 60
Evaporator Heater Load	(W)	280	280	280

SOUND DATA

YLPA Model		Sound Power
		dB(A)
YLPA0115SE	Base Unit	98
YLPA0145SE		99
YLPA0170SE		100
YLPA0115SE	incl. Acoustic Blankets	97
YLPA0145SE		98
YLPA0170SE		99

Dimensions

DIMENSIONS - YLPA 0115SE

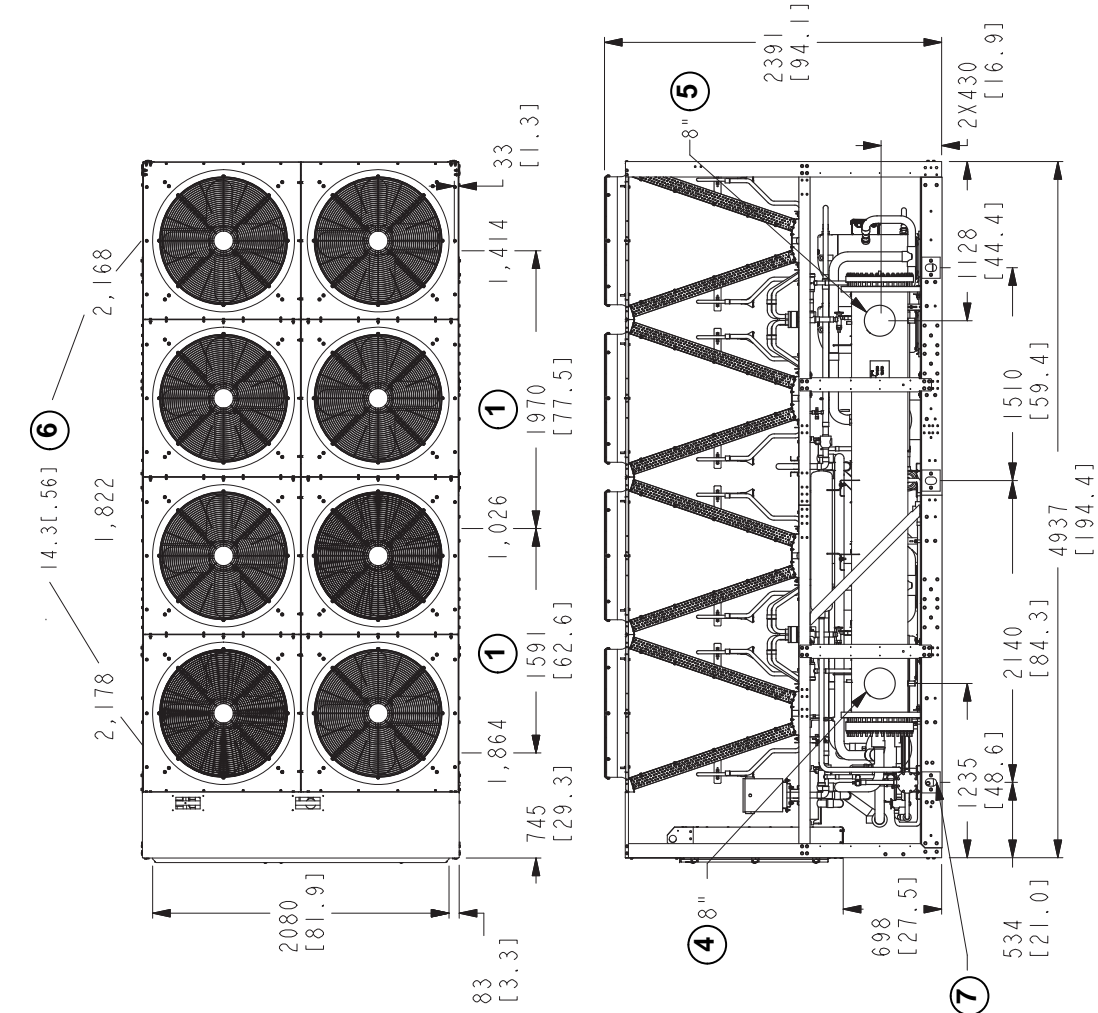

1	Distance between anti vibration mounts
2	Power cable entry via gland plate
3	Control cable entry
4	Water inlet connection to heat exchanger
5	Water outlet connection to heat exchanger
6	Mounting holes for anti vibration mounts
7	Rigging holes

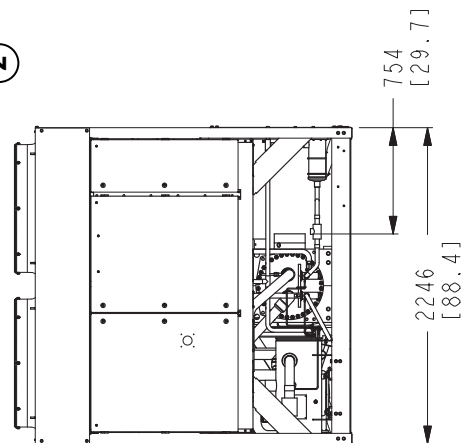
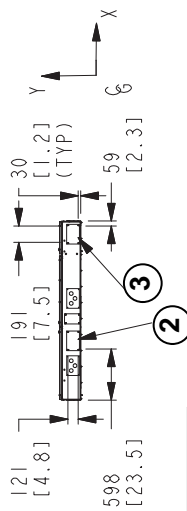

Dimensions - continued

DIMENSIONS - YLPA 0145SE

1	Distance between anti vibration mounts
2	Power cable entry via gland plate
3	Control cable entry
4	Water inlet connection to heat exchanger
5	Water outlet connection to heat exchanger
6	Mounting holes for anti vibration mounts
7	Rigging holes

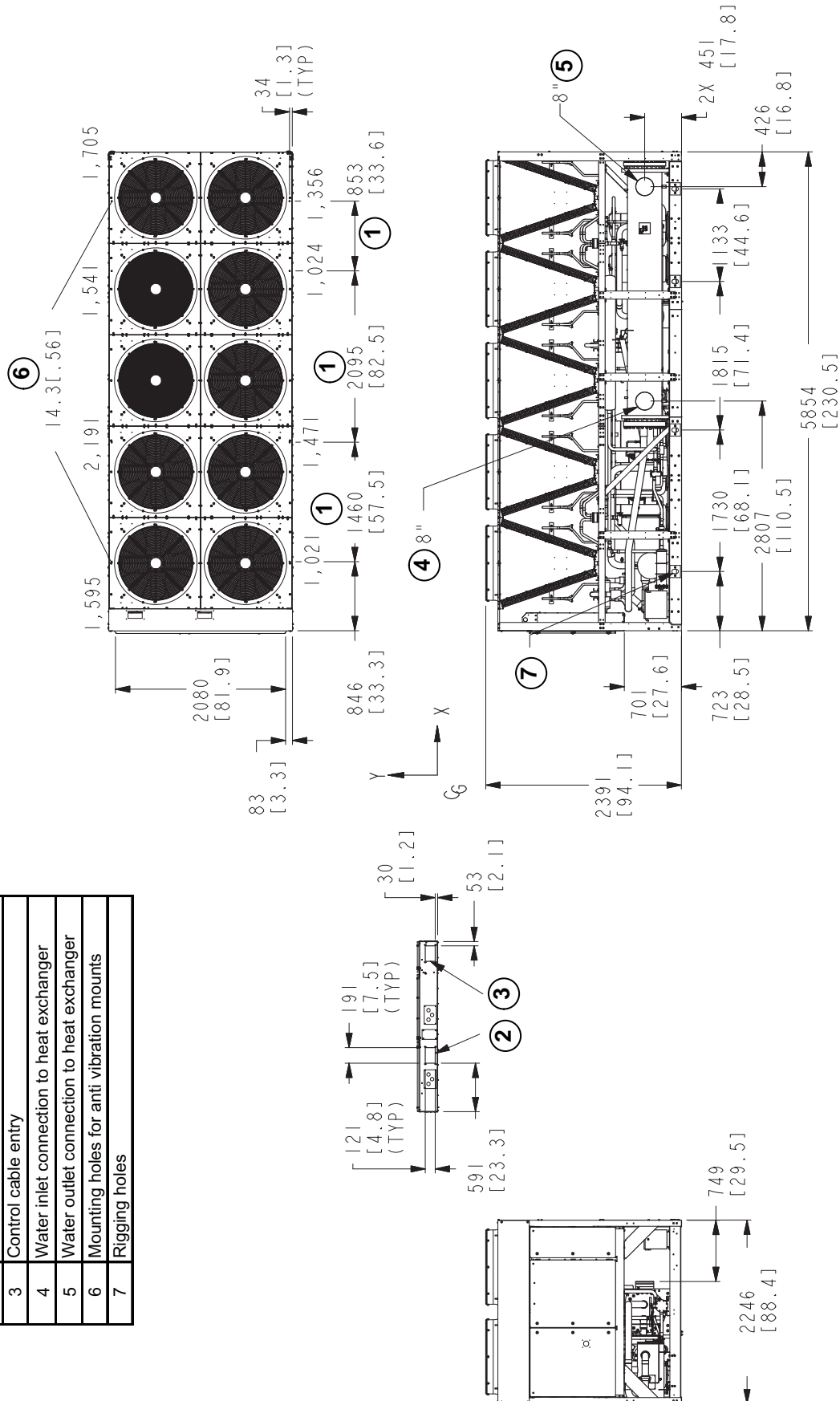

DIMENSIONS - YLPA 0170SE

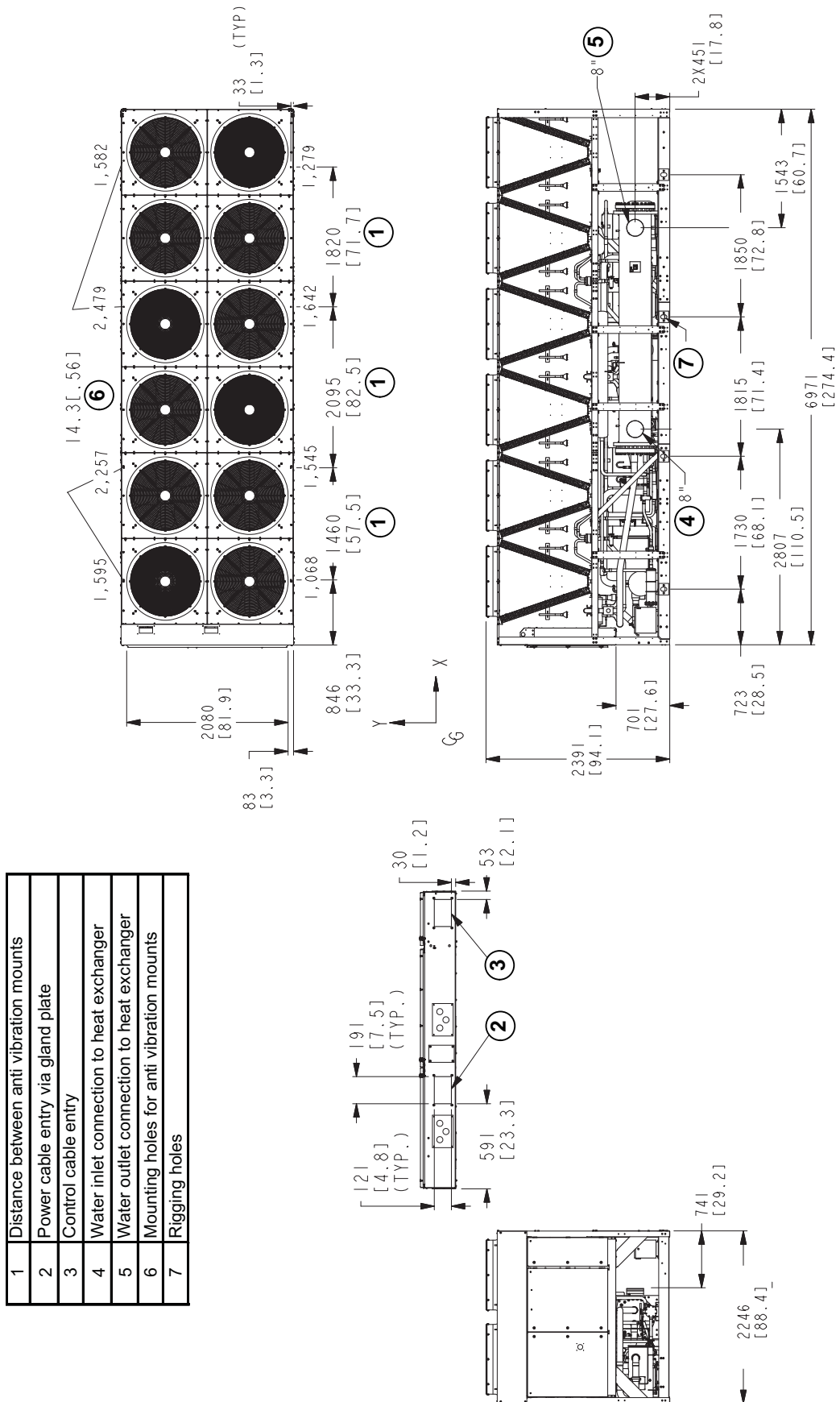

1	Distance between anti vibration mounts
2	Power cable entry via gland plate
3	Control cable entry
4	Water inlet connection to heat exchanger
5	Water outlet connection to heat exchanger
6	Mounting holes for anti vibration mounts
7	Rigging holes



www.johnsoncontrols.com