

# MODEL YCWL WATER-COOLED SCROLL LIQUID CHILLER STYLE A

50 – 200 TONS  
175kW – 700 kW  
60Hz

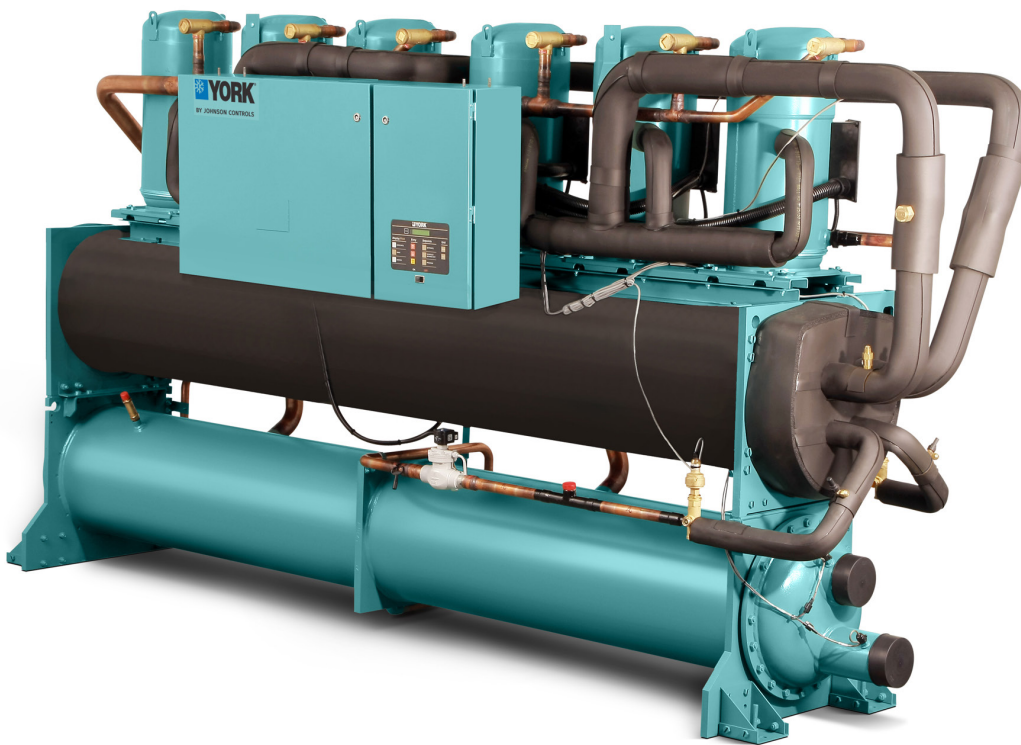

BY JOHNSON CONTROLS

# Nomenclature

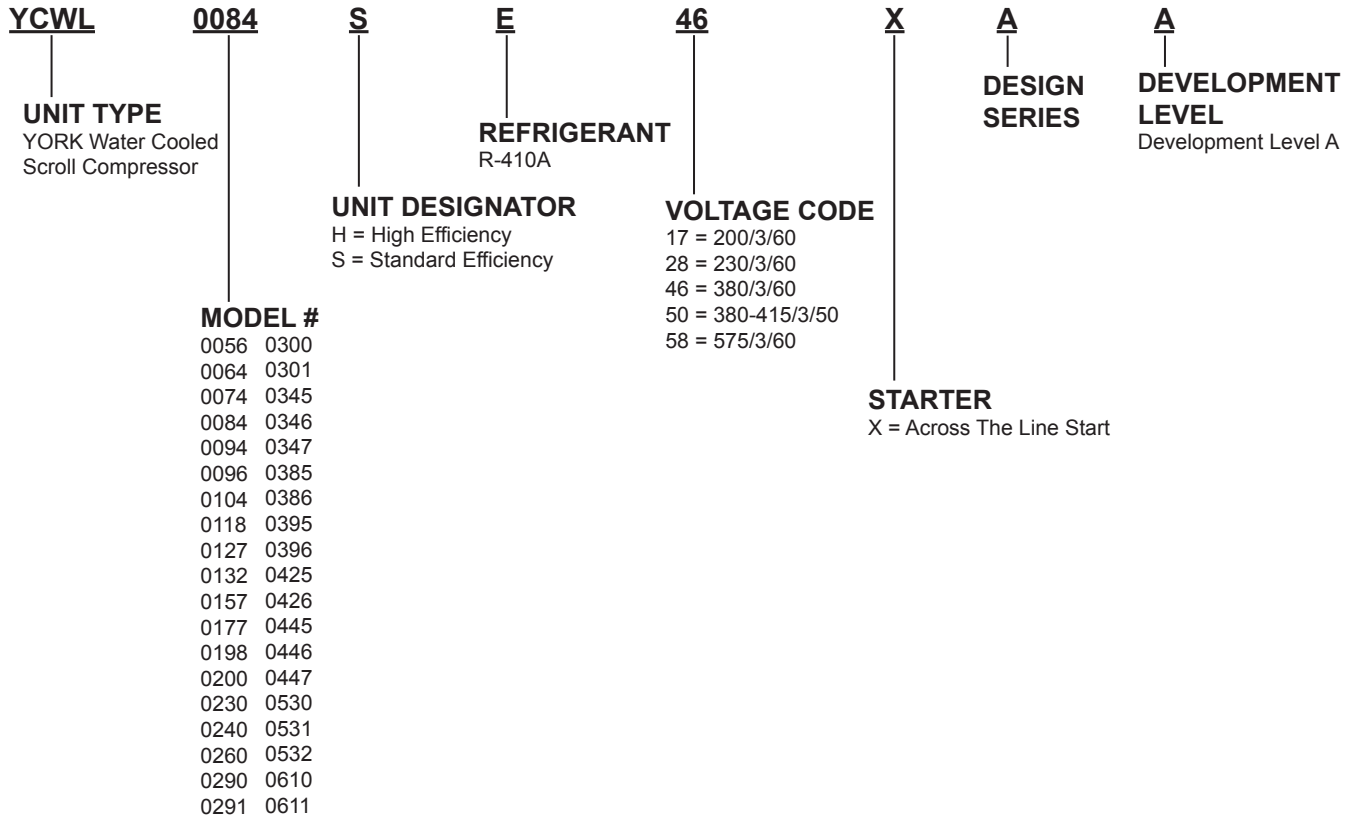

Performance data provided in this document was created in accordance with Johnson Controls software: **YORKworks version 14.03 and DXCHILL version 6.13.**

## Approvals

- ASME Boiler and Pressure Vessel Code –Section VIII Division 1
- AHRI Standard 550/590 and 551/591
- c/U.L. – Underwriters Laboratory
- ASHRAE 15 – Safety Code for Mechanical Refrigeration
- ASHRAE Guideline 3 – Reducing Emission of Halogenated Refrigerants in Refrigeration and Air Conditioning Equipment and Systems
- N.E.C. – National Electrical Code
- OSHA – Occupational Safety and Health Act

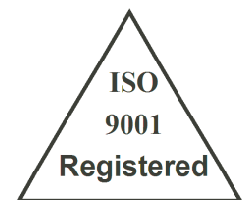

Products are produced at a facility whose quality-management systems are ISO9001 certified.

## ***Table of Contents***

EQUIPMENT OVERVIEW .....	5
MICROPROCESSOR CONTROLS .....	8
ACCESSORIES AND OPTIONS .....	11
REFRIGERANT FLOW DIAGRAM.....	14
DESIGN PARAMETERS .....	15
PRESSURE DROP CURVES .....	16
SELECTION DATA.....	18
RATINGS - STANDARD EFFICIENCY .....	22
RATINGS- HIGH EFFICIENCY .....	25
PART LOAD RATINGS – ENGLISH.....	28
PART LOAD RATINGS – SI .....	29
PHYSICAL DATA – ENGLISH .....	30
ISOLATOR SELECTION DATA .....	34
ISOLATOR INFORMATION .....	35
SOUND DATA .....	38
UNIT DIMENSIONS - FOUR COMPRESSOR.....	40
UNIT DIMENSIONS - FIVE & SIX COMPRESSOR.....	42
SINGLE POINT ELECTRICAL DATA.....	48
DUAL POINT ELECTRICAL DATA.....	56
ELECTRICAL NOTES .....	60
GROUND WIRE SIZING .....	61
TYPICAL CONTROL PANEL WIRING .....	62
CUSTOMER WIRING INFORMATION .....	66
APPLICATION DATA.....	68
GUIDE SPECIFICATIONS .....	70

THIS PAGE INTENTIONALLY LEFT BLANK.

## Equipment Overview

YORK YCWL Water-Cooled chillers provide chilled water for all air conditioning applications that use central station air handling or terminal units. They are completely self-contained and are designed for indoor (new or retrofit) installation. Each unit includes hermetic scroll compressors, a liquid evaporator, water cooled condenser, and a user-friendly, Microcomputer Control Center mounted on a rugged steel base. The units are produced at an ISO 9001 registered facility. The YCWL chillers are rated in accordance with ARI Standard 550/590.

The chiller will be completely assembled with all interconnecting refrigerant piping and internal wiring, ready for field installation.

The unit will be pressure-tested, evacuated, and charged with Refrigerant-410A, and York 'V' (POE) synthetic oil. There will be an operational test, with water flowing through the evaporator, to check that each control device operates correctly.

The unit can be covered with an optional overspray coat of Caribbean Blue enamel. Units are designed in accordance with NFPA 70 (National Electric Code), ASHRAE/ANSI 15 Safety Code for Mechanical Refrigeration. All units are produced at an ISO 9001 registered facility. All YCWL chillers are rated in accordance with ARI Standard 550/590 at ARI conditions.

### COMPRESSORS

The chiller has suction-gas cooled, hermetic, scroll compressors. The YCWL compressors incorporate a compliant scroll design in both the axial and radial direction. All rotating parts are statically and dynamically balanced. A large internal volume provides greater liquid tolerance. Compressor crankcase heaters are also included for extra protection against liquid migration. All compressors are mounted on isolator pads to reduce transmission of vibration to the rest of the unit.

### EVAPORATOR

The dual-circuit evaporator will be the direct-expansion type, with refrigerant in the tubes and chilled liquid flowing through the baffled shell. The design working pressure of the shell (liquid) side will be 150 PSIG (10.3 bar), and 400 PSIG (27.6 bar) for the tube (refrigerant) side.

The evaporator will be constructed and tested in accordance with the applicable sections of the ASME Pressure Vessel Code, Section VIII, Division (1). The water side will be exempt per paragraph U-1, (C), (6).

The removable heads will allow access to the internally enhanced, seamless, copper tubes. Vent and drain connections will be included. Nozzle connections are grooved to accept ANSI/AWWA C-606 couplings.

The evaporator will be covered with 3/4" (19.1 mm) flexible, closed-cell, foam insulation (K = 0.25).

## ***Equipment Overview (Cont'd)***

### **CONDENSER**

The condenser is a cleanable thru-tube type with steel shell, copper tubes, removable water heads, and includes integral subcooling. The design working pressure of the shell (refrigerant) side will be 560 PSIG (38.6 bar) and 150 PSIG (10.3 bar) for the tube (liquid) side. The shell will be constructed and tested in accordance with section VII, division 1 of the ASME pressure-vessel code. The water side is exempt per paragraph U-1, (C), (6) of section VIII, division 1 of the ASME pressure-vessel code. The condenser is equipped with relief valves and will hold the full refrigerant charge for pumpdown. Water connections are grooved to accept ANSI/AWWA C-606 couplings. Vent and drain connections are included.

### **REFRIGERANT CIRCUIT**

Two independent refrigerant circuits will be furnished on each unit. All piping will be copper with brazed joints. The liquid line will include: a shutoff valve with charging port; sight-glass with moisture indicator; thermal expansion valve; solenoid valve; and high-absorption removable-core filter drier. The entire suction line and the liquid line between the expansion valve and the cooler will be insulated with flexible, closed-cell, foam insulation.

### **POWER AND CONTROL PANELS**

All controls and motor starting equipment necessary for unit operation shall be factory wired and function tested. The panel enclosures shall be designed to NEMA 1 (IP 32) and manufactured from powder-painted galvanized steel.

The Power and Control Panel shall be divided into a power section for each electrical system, a common input section and a control section.

Each power panel shall contain:

- Compressor starting contactors
- Control-circuit serving compressor capacity control
- Compressor
- Contactor coils
- Compressor motor overloads

## ***Equipment Overview (Cont'd)***

The compressor motor overloads contain current transformers which sense each phase, as an input to the microprocessor, to protect the compressor motors from damage due to:

- Low input current
- High input current
- Unbalanced current
- Single phasing
- Phase reversal
- Compressor locked rotor

The common input section shall contain:

- Control supply transformer providing 115V
- Customer relay board
- Control circuit switch disconnect/emergency stop device

# Microprocessor Controls

## MICROPROCESSOR CONTROLS

The control section shall contain:

- On/Off rocker switch
- Microcomputer keypad and display
- Microprocessor board
- I/O expansion board
- Relay boards
- 24V fused power-supply board

The control display shall include:

- Liquid Crystal Display with Light Emitting Diode backlighting for outdoor viewing
- Two display lines
- Twenty characters per line

Color coded 12-button non-tactile keypad with sections for display/print of typical information:

- Chilled liquid temperatures
- System pressures (each circuit)
- Operating hours and starts (each compressor)
- Print calls up to the liquid crystal display
- Operating data for the systems
- History of fault shutdown data for up to the last six fault shutdown conditions
- An RS-232 port, in conjunction with this press-to-print button, is provided to permit the capability of hard copy print-outs via a separate printer (by others)

Entry section to:

- ENTER setpoints or modify system values

Setpoints updating can be performed to:

- Chilled liquid temperature setpoint and range
- Remote reset temperature range
- Set daily schedule/holiday for start/stop
- Manual override for servicing
- Number of compressors



## Microprocessor Controls (Cont'd)

- Low liquid temperature cutout
- Low suction pressure cutout
- High discharge pressure cutout
- Anti-recycle timer (compressor start cycle time)
- Anti-coincident timer (delay compressor starts)

Unit section to:

- Set time
- Set unit options

The microprocessor control center is capable of displaying the following:

- Return and leaving chilled liquid temperature
- Low leaving liquid temperature cutout setting
- English or Metric data
- Suction pressure cutout setting
- Each system suction pressure
- Discharge pressure
- Liquid Temperature Reset via a Building Automation System via one of the following:
  - 0-20 VDC input, 0-10 VDC input or a 4-20mA input
  - Anti-recycle timer status for each system
  - Anti-coincident system start timer condition
  - Compressor run status
  - No cooling load condition
  - Day, date and time
  - Daily start/stop times
  - Holiday status
  - Automatic or manual system lead/lag control
  - Lead system definition
  - Compressor starts & operating hours (each compressor)
  - Status of hot gas valves (if supplied)

## ***Microprocessor Controls (Cont'd)***

- Run permissive status
- Number of compressors running
- Liquid solenoid valve status
- Load & unload timer status

The standard controls shall include: brine chilling, automatic pumpdown, run signal contacts, demand load limit from external building automation system input, remote reset liquid temperature reset input, unit alarm contacts, chilled liquid pump control, automatic reset after power failure, and automatic system optimization to match operating conditions. A non-reversing heat pump function (leaving condenser temperature control) is also standard.

The operating program software shall be stored in nonvolatile memory (EPROM) to eliminate chiller failure due to AC power failure. Programmed setpoints are retained in lithium battery-backed regulated time clock (RTC) memory for 5 years minimum.

### **COMMUNICATIONS**

- Native communication capability for BACnet (MS/TP) and Modbus
- Optional communication available for N2 and LON via eLink option

## Accessories and Options

All accessories and options are factory installed unless otherwise noted.

### POWER OPTIONS

**Single Point Supply Terminal Block** - The standard power wiring connection on all models is a single point power connection to a factory provided terminal block. Components included are the enclosure, terminal-block and interconnecting wiring to the compressors. Separate external protection must be supplied, by others, in the incoming power wiring. (Do not include this option if either the Single-Point Non-Fused Disconnect Switch or Single-Point Circuit Breaker options have been included.)

**Single Point Non-Fused Disconnect Switch** - An optional unit-mounted disconnect switch with external, lockable handle (in compliance with Article 440-14 of N.E.C.), can be supplied to isolate the unit power voltage for servicing. Separate external fusing must be supplied, by others in the power wiring, which must comply with the National Electrical Code and/or local codes.

**Single Point Circuit Breaker** - An optional unit mounted circuit breaker with external, lockable handle (in compliance with N.E.C. Article 440-14), can be supplied to isolate the power voltage for servicing.

**Multiple Point Circuit Breaker** – Optional multiple point supply with independent system circuit breakers and locking external handles (in compliance with Article 440-14 of N.E.C) can be factory supplied. Selecting this option also selects optional compressor external overloads, for reduced MCA.

**Control Transformer** – Converts unit power voltage to 115-1-60 (0.5 or 1.0 KVA capacity). Factory mounting includes primary and secondary wiring between the transformer and the control panel.

**Compressor External Overloads** – Optional compressor motor overloads can be factory mounted in the unit control/power panel. This option will reduce the chiller MCA (minimum circuit ampacity) and allow for reduced wire sizing to the unit. This option is not available for applications with Leaving Condenser Water Temperature (**LCWT**) greater than 110°F (43°C).

### CONTROLS OPTIONS

**Language LCD And Keypad** - Standard display language and keypad is in English. Spanish, French, German, and Italian are available as an option.

### HEAT EXCHANGER OPTIONS

**Flow Switch** – An optional flow switch can be factory supplied for the evaporator. Vapor-proof SPDT, NEMA 3R switch, 150 PSIG (10.3 bar) DWP, 20°F to 250°F (-29°C to 121°C) with 1" NPT (IPS) connection for upright mounting in horizontal pipe. The flow switch or its equivalent must be furnished with each unit. (**Field mounted**)

## Accessories and Options (Cont'd)

**Differential Pressure Switch** - An alternative option to the paddle-type flow switch. 3-45 PSIG (0.2-3 bar) range with ¼" NPT pressure connections. **(Field Mounted)**

**Pressure Vessel Codes** - Evaporators and condensers are supplied (Standard) in conformance with the A.S.M.E. pressure codes.

**Flanges (ANSI/AWWA C-606 Couplings Type)** – consists of flange adapters for grooved end pipe on evaporator and condenser (note: the 0064HE and 0094SE units do not include evaporator flanges, and the 0056SE, 0064SE, and 0074SE units do not include condenser flanges). Standard 150 psi (10.3 bar). **(Field-mounted, matching pipe flange by contractor).**

**Double Thick Insulation** – Double Thick (1-1/2") insulation provided on the evaporator.

### CHILLER OPTIONS

**Final Paint Overspray** - Overspray painting of unit after assembly. **(Factory Paint)**

**Service Isolation Valve** - Service suction isolation valve added to unit per system in addition to the standard discharge service valve.

**Hot Gas By-Pass** – Permits continuous, stable operation at capacities below the minimum step of compressor unloading to as low as 5% capacity (depending on both the unit and operating conditions) by introducing an artificial load on the evaporator. Hot gas by-pass is installed on only refrigerant system #2 on two-circuited units.

**Chicago Code Relief Valves** – Unit will be provided with relief valves to meet Chicago code requirements.

**Compressor Acoustic Sound Blanket** – Each compressor is individually enclosed by an acoustic sound blanket. The sound blankets are made with one layer of acoustical absorbent textile fiber of 5/8" (15mm) thickness; one layer of anti-vibrating heavy material thickness of 1/8" (3mm). Both are closed by two sheets of welded PVC, reinforced for temperature and UV resistance.

**Non Reversing Heat Pump** – Unit configured for optional operating mode controlled by leaving condenser water temperature. Temperature setpoint user adjustable from 86°F – 122°F (30°C – 50°C), default 122°F (50°C). While operating in this mode, chiller will stage compressors to maintain heating setpoint provided there is sufficient cooling demand. Unit can be changed from heat pump to chiller mode locally or through BAS. Unit leaving evaporator water temperature will float based on heating output while in this mode, making this option ideal for applications that do not require a constant evaporator leaving temperature or for multiple (series) chiller installations. Option requires factory startup and adds one day startup labor for field configuration. Requires evaporator leaving temperature above 40°F (4°C) while heat pump is in operation.

## ***Accessories and Options (Cont'd)***

### **VIBRATION ISOLATION**

**Elastomeric Isolation** – Recommended for normal installations. Provides very good performance in most applications for the least cost. **(Field-Mounted)**

**1" Spring Isolators** – Level adjustable, spring and cage type isolators for mounting under the unit base rails. 1" nominal deflection may vary slightly by application. **(Field -Mounted)**

**2" Seismic Isolators** – Restrained spring-flex mountings incorporate a rugged welded steel housing with vertical and horizontal limit stops. Housings designed to withstand a minimum 1.0g accelerated force in all directions to 2". Level adjustable, deflection may vary slightly by application. **(Field-Mounted)**

# Refrigerant Flow Diagram

Low-pressure liquid refrigerant enters the evaporator tubes and is evaporated and superheated by the heat energy absorbed from the chilled liquid passing through the evaporator shell. Low-pressure vapor enters the compressor where pressure and superheat are increased. High-pressure vapor is passed through the condenser where heat is rejected to the condenser water passing through the tubes. The fully condensed and subcooled liquid leaves the condenser and enters the expansion valve, where pressure reduction and further cooling take place. The low pressure liquid refrigerant then returns to the evaporator.

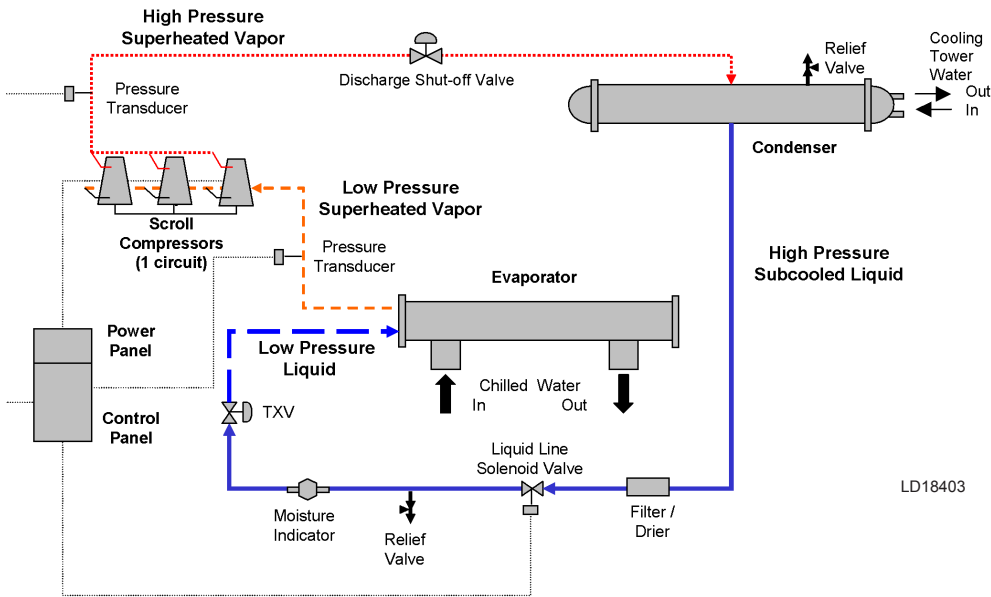

LD18403

## Design Parameters

DESIGN PARAMETERS - STANDARD EFFICIENCY (SE)										
YCWL MODEL	EVAPORATOR FLOW GPM (L/S)		CONDENSER FLOW GPM (L/S)		LEAVING EVAP. WATER TEMP. °F (°C)		ENT. COND. WATER TEMP. °F (°C)	LVG. COND. WATER TEMP. °F (°C)	EQUIPMENT ROOM TEMP °F (°C)	
	MIN	MAX	MIN	MAX	MIN1	MAX2	MIN	MAX	MIN	MAX
0056SE	60 (3.8)	285 (18)	90 (5.7)	360 (22.7)	40 (4.4)	50 (10)	65 (18)	130 (54)	40 (4.4)	115 (46)
0064SE	60 (3.8)	285 (18)	90 (5.7)	360 (22.7)	40 (4.4)	50 (10)	65 (18)	130 (54)	40 (4.4)	115 (46)
0074SE	60 (3.8)	285 (18)	90 (5.7)	360 (22.7)	40 (4.4)	50 (10)	65 (18)	130 (54)	40 (4.4)	115 (46)
0084SE	60 (3.8)	285 (18)	145 (9.1)	450 (28.4)	40 (4.4)	50 (10)	65 (18)	130 (54)	40 (4.4)	115 (46)
0094SE	100 (6.3)	385 (24.3)	145 (9.1)	450 (28.4)	40 (4.4)	50 (10)	65 (18)	130 (54)	40 (4.4)	115 (46)
0104SE	100 (6.3)	385 (24.3)	145 (9.1)	450 (28.4)	40 (4.4)	50 (10)	65 (18)	130 (54)	40 (4.4)	115 (46)
0118SE	100 (6.3)	385 (24.3)	145 (9.1)	450 (28.4)	40 (4.4)	50 (10)	65 (18)	130 (54)	40 (4.4)	115 (46)
0132SE	140 (8.8)	625 (39.4)	180 (11.4)	700 (44.2)	40 (4.4)	50 (10)	65 (18)	130 (54)	40 (4.4)	115 (46)
0157SE	150 (9.5)	625 (39.4)	225 (14.2)	700 (44.2)	40 (4.4)	50 (10)	65 (18)	130 (54)	40 (4.4)	115 (46)
0177SE	200 (12.6)	650 (41)	260 (16.4)	700 (44.2)	40 (4.4)	50 (10)	65 (18)	130 (54)	40 (4.4)	115 (46)
0198SE	200 (12.6)	650 (41)	260 (16.4)	700 (44.2)	40 (4.4)	50 (10)	65 (18)	130 (54)	40 (4.4)	115 (46)
DESIGN PARAMETERS - HIGH EFFICIENCY (HE)										
YCWL MODEL	EVAPORATOR FLOW GPM (L/S)		CONDENSER FLOW GPM (L/S)		LEAVING EVAP. WATER TEMP. °F (°C)		ENT. COND. WATER TEMP. °F (°C)	LVG. COND. WATER TEMP. °F (°C)	EQUIPMENT ROOM TEMP °F (°C)	
	MIN	MAX	MIN	MAX	MIN1	MAX2	MIN	MAX	MIN	MAX
0064HE	100 (6.3)	355 (22.4)	145 (9.1)	450 (28.4)	40 (4.4)	50 (10)	65 (18)	130 (54)	40 (4.4)	115 (46)
0074HE	140 (8.8)	625 (39.4)	145 (9.1)	450 (28.4)	40 (4.4)	50 (10)	65 (18)	130 (54)	40 (4.4)	115 (46)
0084HE	140 (8.8)	625 (39.4)	145 (9.1)	450 (28.4)	40 (4.4)	50 (10)	65 (18)	130 (54)	40 (4.4)	115 (46)
0094HE	140 (8.8)	625 (39.4)	225 (14.2)	700 (44.2)	40 (4.4)	50 (10)	65 (18)	130 (54)	40 (4.4)	115 (46)
0096HE	150 (9.5)	625 (39.4)	225 (14.2)	700 (44.2)	40 (4.4)	50 (10)	65 (18)	130 (54)	40 (4.4)	115 (46)
0118HE	140 (8.8)	625 (39.4)	225 (14.2)	700 (44.2)	40 (4.4)	50 (10)	65 (18)	130 (54)	40 (4.4)	115 (46)
0127HE	200 (12.6)	650 (41)	225 (14.2)	700 (44.2)	40 (4.4)	50 (10)	65 (18)	130 (54)	40 (4.4)	115 (46)
0157HE	200 (12.6)	650 (41)	260 (16.4)	700 (44.2)	40 (4.4)	50 (10)	65 (18)	130 (54)	40 (4.4)	115 (46)

**NOTES:**

1. For leaving temperature below 40°F (4.4°C), optional brine chilling kit required. Minimum with kit is 15°F (-9.4°C).
2. For leaving water temperature higher than 50°F (10°C), contact the nearest Johnson Controls Office for application guidelines.

# Pressure Drop Curves

YCWL Evaporator Pressure Drop (English Units)

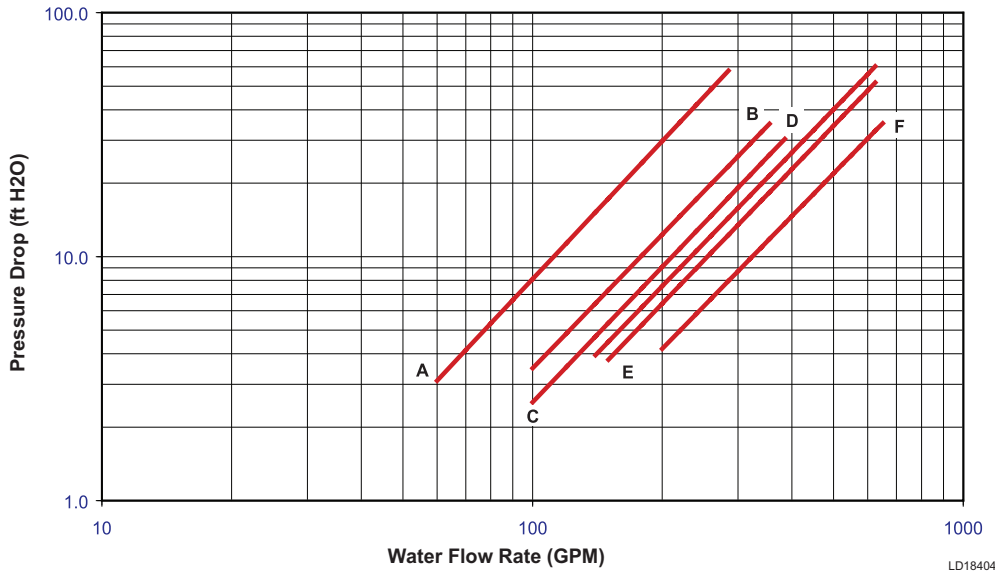

EVAPORATOR	YCWL MODEL NUMBER
A	0056SE, 0064SE, 0074SE, 0084SE
B	0064HE, 0094SE
C	0104SE, 0118SE
D	0074HE, 0084HE, 0094HE, 0118HE, 0132SE
E	0096HE, 0157SE
F	0127HE, 0157HE, 0198SE

YCWL Evaporator Pressure Drop (SI Units)

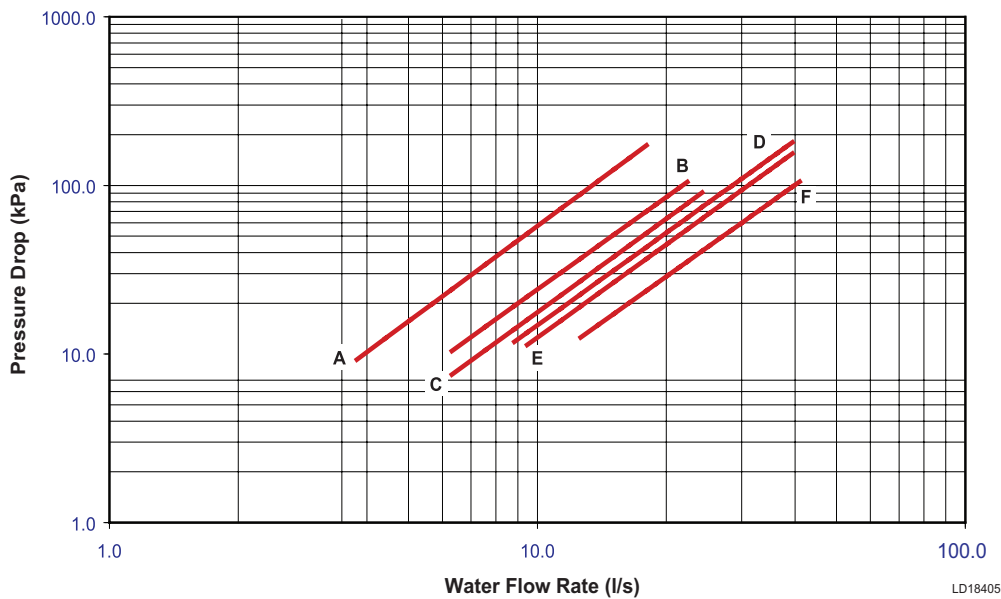



# Pressure Drop Curves (Cont'd)

YCWL Condenser Pressure Drop (English Units)

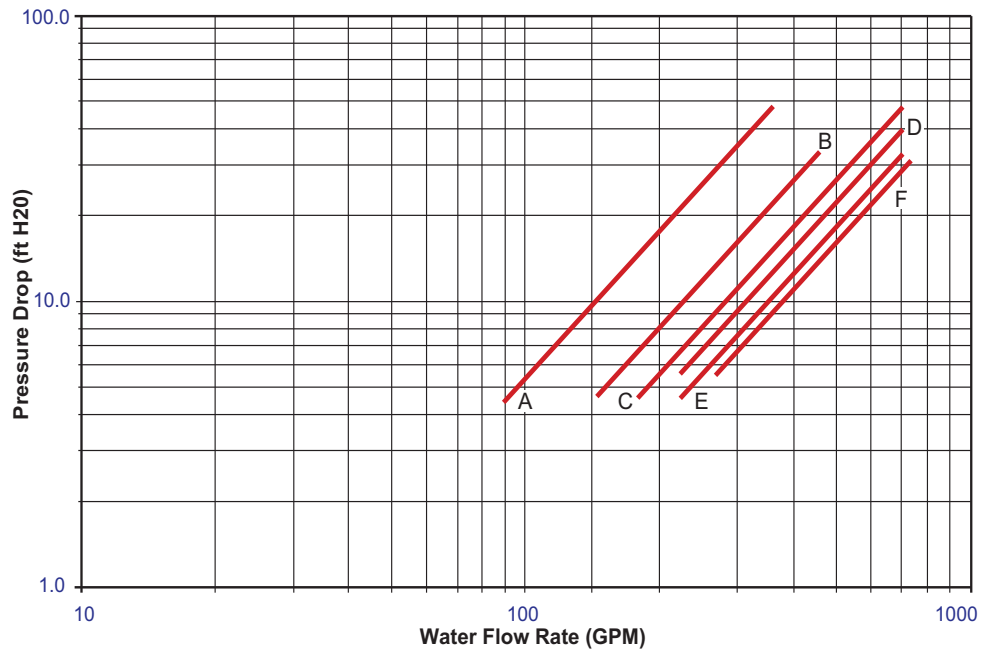

LD18406

EVAPORATOR	YCWL MODEL NUMBER
A	0056SE, 0064SE, 0074SE, 0084SE
B	0064HE, 0094SE
C	0104SE, 0118SE
D	0074HE, 0084HE, 0094HE, 0118HE, 0132SE
E	0096HE, 0157SE
F	0127HE, 0157HE, 0198SE

YCWL Condenser Pressure Drop (SI Units)

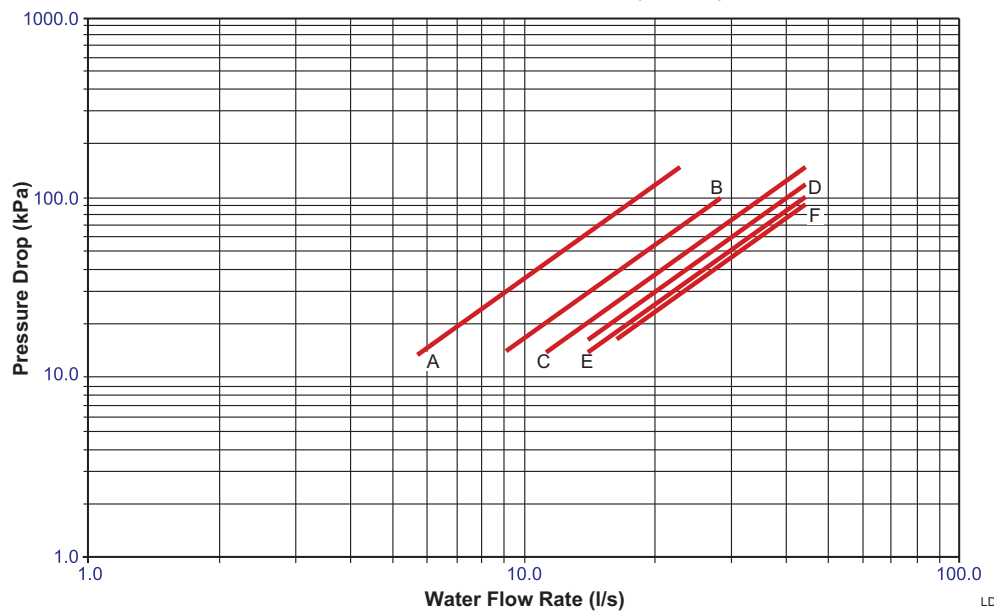

LD18407

# Selection Data

## GUIDE TO SELECTION

Complete water chilling capacity ratings for YORK YCWL chillers are shown on the following pages to cover the majority of job requirements. For any application beyond the scope of this Engineering Guide, consult your nearest Johnson Controls office.

### Selection Rules

- 1. Ratings** - All YCWL ratings are in accordance with ARI Standard 550/590, at the ARI standard conditions. Ratings not at standard ARI conditions are rated in accordance with ARI rating procedures. These ratings may be interpolated but should not be extrapolated.

$$\text{Cond. GPM} = \frac{\text{MBH} \times 2}{\text{Cond. Water Range (}^{\circ}\text{F)}}$$

EVAPORATOR CORRECTION FACTORS				
FF=TEMP SPLIT	0.00010		0.00025	
	TONS	COMPR KW	TONS	COMPR KW
6	0.976	0.996	0.969	0.997
8	0.990	0.999	0.960	0.996
10	1.000	1.000	0.991	0.999
12	1.009	1.001	0.999	1.000
14	1.017	1.002	1.007	1.001

- 2. Cooling Water Quantity** - Ratings are based on 10°F chilled water range with the evaporator at sea level. Use the chilled water correction factors (below) for other ranges except as limited by water pressure drop, minimum or maximum water flows for the evaporator.

CONDENSER CORRECTION FACTORS				
FF=TEMP SPLIT	0.00025		0.00050	
	TONS	COMPR KW	TONS	COMPR KW
6	1.020	0.963	1.014	0.974
8	1.010	0.982	1.019	0.990
10	1.000	1.000	0.995	1.010
12	0.990	1.019	0.985	1.029
14	0.980	1.040	0.975	1.048

Note: Temperature split factors @ 85°F Entering Condenser Water Temp (ECWT)

- 3. Condenser Water Quantity** – Ratings are applicable from 2 to 4 GPM/Ton. Use the condenser water correction factors (below) for different ranges except as limited by water pressure drop or minimum or maximum water flows for the condenser. Using the heat rejection (MBH), the Condenser GPM is calculated as follows:
- 4. FOULING FACTORS** – Ratings are based on 0.0001 evaporator and 0.00025 condenser fouling factor. For other fouling factors, consult the table below or contact your Johnson Controls representative.

## Selection Data (Cont'd)

5. **ETHYLENE GLYCOL CORRECTION FACTORS** – The following factors are to be applied to the standard ratings for units cooling ethylene glycol.

ETHYLENE GLYCOL					
%WEIGHT	TONS	COMPR KW	GPM	PRESS DROP	FREEZE POINT
10	0.993	1.002	1.029	1.095	26
20	0.980	1.004	1.040	1.191	18
30	0.964	1.007	1.055	1.302	7
40	0.945	1.009	1.071	1.435	-8
50	0.922	1.013	1.091	1.599	-29

6. **PROPYLENE GLYCOL CORRECTION FACTORS** – The following factors are to be applied to the standard ratings for units cooling propylene glycol.

PROPYLENE GLYCOL					
%WEIGHT	TONS	COMPR KW	GPM	PRESS DROP	FREEZE POINT
10	0.985	1.002	1.003	1.078	28
20	0.968	1.005	1.000	1.157	19
30	0.937	1.008	0.992	1.288	9
40	0.898	1.012	0.982	1.414	<1
50	0.862	1.019	0.985	1.605	-28

### METHOD OF SELECTION

If the duty requires a 10°F range on both the evaporator and condenser, see “Ratings”. For water ranges other than 10°F, use the following procedure.

- Determine capacity required from the following formula.

$$\text{Capacity (Tons)} = \frac{\text{GPM} \times \text{Chilled Water Range (°F)}}{24}$$

- After applying any fouling factor corrections, the actual condenser heat rejection may be determined as follows:

$$\text{Heat Rejection (MBH)} = \frac{\text{Heat Rejection (Btuh)}}{1000}$$

$$= (\text{Tons} \times 12) = (\text{kW} \times 3.415)$$

- Determine condensing water requirements for water cooled models as follows:

$$\text{Condenser Tons} = \frac{\text{Heat Rejection (MBH)} \times 1000}{15,000}$$

## Selection Data (Cont'd)

Or combine the two formulas:

$$\text{Cond. Water GPM} = \frac{\text{Condenser Tons} \times 30}{\text{Condenser Water Range (°F)}}$$

### SAMPLE SELECTION

Water Cooled Chiller (YCWL)

**GIVEN** – Chill 200 GPM of water from 56°F to 44°F and 0.0001 evaporator fouling factor with 85°F to 95°F condensing water available. The fouling factor is 0.0005 for the condenser.

**FIND** – The required unit size capacity, kW, EER, and water pressure drop.

### SOLUTION:

1. Chilled water range = 56°F - 44°F = 12°F and correction factors are 1.009 for Tons and 1.001 for kW for the evaporator.

$$\begin{aligned} \text{Capacity (Tons)} &= \frac{\text{GPM} \times \text{Chilled Water Range}}{24} \\ &= \frac{200 \times 12}{24} = 100\text{TR} \end{aligned}$$

2. From the rating, a model YCWL01180SE has a capacity range required. For the evaporator leaving water temperature of 44°F and a condenser leaving water temperature of 95°F, the unit capacity rating table indicates:

Tons	=	108.4
KW	=	83.5
EER	=	15.6

Correcting for the 12°F chilled water range and the 0.0005 condenser-fouling factor (Correction factors for the condenser are 0.995 for Tons and 1.010 for kW):

$$\text{Tons} = 108.4 \times 1.009 \times 0.995 = 108.8\text{TR}$$

$$\text{KW} = 83.5 \times 1.001 \times 1.010 = 84.4 \text{ kW}$$

3. Determine the average full load kW and EER at 100 Tons.

## Selection Data (Cont'd)

$$\frac{100}{108.8} \times (84.4) = 77.6 \text{ kW}$$

$$\text{EER} = \frac{\text{Tons} \times 12}{\text{kW}} = \frac{100 \times 12}{77.6} = 15.5$$

4. Determine the cond. Heat rejection as follows:

$$\begin{aligned} \text{Heat Rejection (MBH)} &= (\text{Tons} \times 12) + (\text{kW} \times 3.415) \\ &= (108.8 \times 12) + (84.4 \times 3.415) \\ &= 1306 + 288 \\ &= 1594 \end{aligned}$$

5. Determine the GPM of condensing water as follows:

$$\begin{aligned} \text{GPM Condenser Water} &= \frac{\text{MBH} \times 2}{\text{Cond. Water Range}} \\ &= \frac{1594 \times 2}{10} \\ &= 319 \text{ GPM} \end{aligned}$$

6. From curves on pages 14 and 15, the pressure drops with 200 GPM through the evaporator and 319 GPM through the condenser of the Model YCWL118SE:

Evaporator Pressure Drop at 200 GPM = 9 ft

Condenser Pressure Drop at 319 GPM = 18 ft

**The unit is suitable.**

# Ratings - Standard Efficiency

MODEL: YCWL0056SE											IPLV= 21.3	
ENTERING CONDENSER WATER TEMPERATURE (°F)												
LCWT (°F)	75.0				85.0				95.0			
	TONS	KW	MBH	EER	TONS	KW	MBH	EER	TONS	KW	MBH	EER
40.0	50.7	33.9	724.0	17.9	48.1	37.7	705.0	15.3	45.3	42.0	686.0	12.9
42.0	52.6	34.1	747.0	18.5	49.8	37.8	727.0	15.8	47.0	42.2	708.0	13.4
44.0	54.4	34.3	770.0	19.0	51.6	37.9	749.0	16.3	48.8	42.3	729.0	13.8
46.0	56.4	34.5	794.0	19.6	53.5	38.1	771.0	16.8	50.5	42.4	751.0	14.3
48.0	58.3	34.7	818.0	20.2	55.4	38.3	795.0	17.4	52.3	42.5	773.0	14.8
50.0	60.3	34.9	843.0	20.7	57.3	38.5	819.0	17.9	54.2	42.7	796.0	15.2

MODEL: YCWL0064SE											IPLV= 19.9	
ENTERING CONDENSER WATER TEMPERATURE (°F)												
LCWT (°F)	75.0				85.0				95.0			
	TONS	KW	MBH	EER	TONS	KW	MBH	EER	TONS	KW	MBH	EER
40.0	58.8	41.0	845.0	17.2	55.8	45.3	824.0	14.8	52.7	50.7	806.0	12.5
42.0	60.9	41.3	871.0	17.7	57.9	45.5	849.0	15.3	54.7	50.8	829.0	12.9
44.0	63.1	41.6	898.0	18.2	60.0	45.7	875.0	15.8	56.7	50.9	854.0	13.4
46.0	65.3	42.0	926.0	18.7	62.1	45.9	901.0	16.2	58.7	51.0	879.0	13.8
48.0	67.5	42.4	954.0	19.1	64.3	46.2	929.0	16.7	60.8	51.2	904.0	14.3
50.0	69.9	42.8	984.0	19.6	66.5	46.5	956.0	17.2	63.0	51.4	931.0	14.7

MODEL: YCWL0074SE											IPLV= 20.2	
ENTERING CONDENSER WATER TEMPERATURE (°F)												
LCWT (°F)	75.0				85.0				95.0			
	TONS	KW	MBH	EER	TONS	KW	MBH	EER	TONS	KW	MBH	EER
40.0	66.7	48.1	964.0	16.6	63.2	53.1	939.0	14.3	59.5	59.0	915.0	12.1
42.0	69.1	48.4	994.0	17.1	65.5	53.3	967.0	14.7	61.8	59.2	943.0	12.5
44.0	71.5	48.7	1024.0	17.6	67.9	53.5	997.0	15.2	64.0	59.4	971.0	12.9
46.0	74.1	49.0	1056.0	18.1	70.3	53.8	1027.0	15.7	66.4	59.6	999.0	13.4
48.0	76.7	49.3	1088.0	18.7	72.8	54.1	1057.0	16.1	68.7	59.9	1029.0	13.8
50.0	79.3	49.6	1121.0	19.2	75.3	54.4	1089.0	16.6	71.2	60.1	1059.0	14.2

MODEL: YCWL0084SE											IPLV= 21.5	
ENTERING CONDENSER WATER TEMPERATURE (°F)												
LCWT (°F)	75.0				85.0				95.0			
	TONS	KW	MBH	EER	TONS	KW	MBH	EER	TONS	KW	MBH	EER
40.0	75.4	52.4	1083.0	17.3	71.3	57.7	1052.0	14.8	67.1	63.8	1023.0	12.6
42.0	78.1	52.6	1117.0	17.8	73.9	58.0	1085.0	15.3	69.6	64.1	1054.0	13.0
44.0	81.0	52.8	1151.0	18.4	76.6	58.2	1118.0	15.8	72.2	64.3	1086.0	13.5
46.0	83.9	53.0	1187.0	19.0	79.4	58.4	1152.0	16.3	74.9	64.6	1119.0	13.9
48.0	86.8	53.1	1223.0	19.6	82.3	58.7	1187.0	16.8	77.6	64.9	1152.0	14.4
50.0	89.9	53.3	1260.0	20.2	85.2	58.9	1222.0	17.4	80.4	65.1	1186.0	14.8

## NOTES:

1. Tons = Unit Cooling Capacity Output
2. KW = Compressor Input Power
3. MBH = Condenser Heat Rejection
4. EER = Chiller Energy Efficiency Ratio
5. LCWT = Leaving Chilled Water Temperature

## Ratings - Standard Efficiency (Cont'd)

MODEL: YCWL0094SE											IPLV= 21.6	
ENTERING CONDENSER WATER TEMPERATURE (°F)												
LCWT (°F)	75.0				85.0				95.0			
	TONS	KW	MBH	EER	TONS	KW	MBH	EER	TONS	KW	MBH	EER
40.0	84.4	57.1	1207.0	17.7	80.1	63.1	1176.0	15.2	75.5	70.1	1145.0	12.9
42.0	87.5	57.4	1245.0	18.3	83.0	63.4	1212.0	15.7	78.3	70.3	1179.0	13.4
44.0	90.6	57.6	1283.0	18.9	86.0	63.6	1249.0	16.2	81.2	70.6	1215.0	13.8
46.0	93.8	57.9	1322.0	19.4	89.0	63.9	1286.0	16.7	84.1	70.8	1251.0	14.2
48.0	97.0	58.2	1363.0	20.0	92.2	64.2	1325.0	17.2	87.1	71.1	1288.0	14.7
50.0	100.4	58.4	1404.0	20.6	95.4	64.5	1365.0	17.8	90.2	71.4	1326.0	15.2

MODEL: YCWL0104SE											IPLV= 21.0	
ENTERING CONDENSER WATER TEMPERATURE (°F)												
LCWT (°F)	75.0				85.0				95.0			
	TONS	KW	MBH	EER	TONS	KW	MBH	EER	TONS	KW	MBH	EER
40.0	91.1	61.6	1302.0	17.7	86.7	68.2	1272.0	15.3	82.0	75.9	1243.0	13.0
42.0	94.3	61.9	1342.0	18.3	89.8	68.5	1310.0	15.7	85.0	76.2	1279.0	13.4
44.0	97.6	62.3	1384.0	18.8	93.0	68.8	1350.0	16.2	88.0	76.4	1317.0	13.8
46.0	101.0	62.7	1426.0	19.3	96.2	69.1	1390.0	16.7	91.2	76.7	1356.0	14.3
48.0	104.5	63.1	1469.0	19.9	99.6	69.5	1431.0	17.2	94.4	77.0	1395.0	14.7
50.0	108.1	63.6	1513.0	20.4	103.0	69.8	1474.0	17.7	97.7	77.3	1435.0	15.2

MODEL: YCWL0118SE											IPLV= 23.7	
ENTERING CONDENSER WATER TEMPERATURE (°F)												
LCWT (°F)	75.0				85.0				95.0			
	TONS	KW	MBH	EER	TONS	KW	MBH	EER	TONS	KW	MBH	EER
40.0	108.9	73.1	1557.0	17.9	103.2	84.7	1528.0	14.6	97.1	98.3	1500.0	11.9
42.0	112.7	72.9	1601.0	18.6	106.9	84.4	1570.0	15.2	100.6	97.9	1541.0	12.3
44.0	116.6	72.7	1647.0	19.3	110.6	84.2	1614.0	15.8	104.2	97.6	1583.0	12.8
46.0	120.6	72.5	1694.0	20.0	114.4	83.9	1659.0	16.4	107.8	97.2	1625.0	13.3
48.0	124.7	72.3	1743.0	20.7	118.3	83.6	1705.0	17.0	111.5	96.9	1669.0	13.8
50.0	128.9	72.1	1793.0	21.5	122.3	83.4	1752.0	17.6	115.4	96.6	1714.0	14.3

MODEL: YCWL0132SE											IPLV= 23.7	
ENTERING CONDENSER WATER TEMPERATURE (°F)												
LCWT (°F)	75.0				85.0				95.0			
	TONS	KW	MBH	EER	TONS	KW	MBH	EER	TONS	KW	MBH	EER
40.0	125.6	81.2	1784.0	18.6	119.0	93.9	1748.0	15.2	111.9	108.7	1713.0	12.3
42.0	130.0	81.0	1837.0	19.3	123.2	93.6	1798.0	15.8	115.9	108.4	1761.0	12.8
44.0	134.6	80.8	1890.0	20.0	127.6	93.4	1849.0	16.4	120.0	108.1	1809.0	13.3
46.0	139.2	80.7	1946.0	20.7	132.0	93.1	1902.0	17.0	124.3	107.7	1859.0	13.8
48.0	144.0	80.5	2003.0	21.5	136.6	92.9	1956.0	17.6	128.6	107.4	1910.0	14.4
50.0	148.9	80.4	2061.0	22.2	141.3	92.7	2011.0	18.3	133.1	107.1	1963.0	14.9

## NOTES:

1. Tons = Unit Cooling Capacity Output
2. KW = Compressor Input Power
3. MBH = Condenser Heat Rejection
4. EER = Chiller Energy Efficiency Ratio
5. LCWT = Leaving Chilled Water Temperature

## Ratings - Standard Efficiency (Cont'd)

MODEL: YCWL0157SE											IPLV= 23.6	
ENTERING CONDENSER WATER TEMPERATURE (°F)												
LCWT (°F)	75.0				85.0				95.0			
	TONS	KW	MBH	EER	TONS	KW	MBH	EER	TONS	KW	MBH	EER
40.0	142.3	91.1	2018.0	18.7	134.2	104.9	1968.0	15.4	125.9	120.9	1923.0	12.5
42.0	147.4	90.9	2079.0	19.5	139.1	104.6	2026.0	16.0	130.6	120.5	1978.0	13.0
44.0	152.7	90.7	2141.0	20.2	144.2	104.3	2086.0	16.6	135.4	120.1	2034.0	13.5
46.0	158.1	90.5	2206.0	21.0	149.4	104.0	2147.0	17.2	140.3	119.7	2092.0	14.1
48.0	163.7	90.3	2272.0	21.7	154.7	103.7	2209.0	17.9	145.4	119.3	2152.0	14.6
50.0	169.3	90.1	2339.0	22.5	160.1	103.4	2273.0	18.6	150.5	118.9	2212.0	15.2

MODEL: YCWL0177SE											IPLV= 25.5	
ENTERING CONDENSER WATER TEMPERATURE (°F)												
LCWT (°F)	75.0				85.0				95.0			
	TONS	KW	MBH	EER	TONS	KW	MBH	EER	TONS	KW	MBH	EER
40.0	164.4	101.2	2318.0	19.5	155.7	117.2	2268.0	15.9	146.4	135.9	2220.0	12.9
42.0	170.2	100.9	2387.0	20.2	161.3	116.8	2334.0	16.6	151.7	135.4	2282.0	13.4
44.0	176.2	100.6	2458.0	21.0	167.0	116.4	2402.0	17.2	157.2	134.9	2346.0	14.0
46.0	182.4	100.4	2531.0	21.8	172.9	116.0	2471.0	17.9	162.8	134.4	2412.0	14.5
48.0	188.8	100.2	2607.0	22.6	179.0	115.7	2542.0	18.6	168.6	133.9	2480.0	15.1
50.0	195.3	100.0	2684.0	23.4	185.2	115.3	2616.0	19.3	174.5	133.4	2549.0	15.7

MODEL: YCWL0198SE											IPLV= 24.9	
ENTERING CONDENSER WATER TEMPERATURE (°F)												
LCWT (°F)	75.0				85.0				95.0			
	TONS	KW	MBH	EER	TONS	KW	MBH	EER	TONS	KW	MBH	EER
40.0	195.7	122.5	2766.0	19.2	185.6	141.8	2710.0	15.7	174.7	164.2	2656.0	12.8
42.0	202.6	122.2	2848.0	19.9	192.1	141.3	2788.0	16.3	180.9	163.7	2729.0	13.3
44.0	209.6	121.9	2931.0	20.6	198.9	140.9	2867.0	16.9	187.4	163.1	2805.0	13.8
46.0	216.9	121.6	3018.0	21.4	205.8	140.5	2949.0	17.6	194.0	162.6	2882.0	14.3
48.0	224.4	121.3	3106.0	22.2	212.9	140.1	3033.0	18.2	200.7	162.1	2962.0	14.9
50.0	232.0	121.1	3197.0	23.0	220.3	139.7	3120.0	18.9	207.8	161.6	3045.0	15.4

## NOTES:

1. Tons = Unit Cooling Capacity Output
2. KW = Compressor Input Power
3. MBH = Condenser Heat Rejection
4. EER = Chiller Energy Efficiency Ratio
5. LCWT = Leaving Chilled Water Temperature



## Ratings- High Efficiency

MODEL: YCWL0064HE											IPLV= 21.5	
ENTERING CONDENSER WATER TEMPERATURE (°F)												
LCWT (°F)	75.0				85.0				95.0			
	TONS	KW	MBH	EER	TONS	KW	MBH	EER	TONS	KW	MBH	EER
40.0	61.9	41.1	883.0	18.1	58.8	45.9	862.0	15.4	55.4	51.1	839.0	13.0
42.0	64.1	41.3	910.0	18.6	61.0	46.1	889.0	15.9	57.5	51.3	865.0	13.5
44.0	66.4	41.6	938.0	19.2	63.2	46.3	916.0	16.4	59.6	51.5	891.0	13.9
46.0	68.7	41.8	967.0	19.7	65.4	46.6	944.0	16.9	61.8	51.7	918.0	14.4
48.0	71.1	42.1	996.0	20.2	67.7	46.8	972.0	17.3	64.0	52.0	945.0	14.8
50.0	73.5	42.5	1026.0	20.8	70.0	47.2	1001.0	17.8	66.3	52.2	973.0	15.2

MODEL: YCWL0074HE											IPLV= 22.7	
ENTERING CONDENSER WATER TEMPERATURE (°F)												
LCWT (°F)	75.0				85.0				95.0			
	TONS	KW	MBH	EER	TONS	KW	MBH	EER	TONS	KW	MBH	EER
40.0	72.0	47.0	1024.0	18.4	67.7	54.0	996.0	15.1	63.4	61.8	971.0	12.3
42.0	74.8	46.9	1057.0	19.1	70.3	53.9	1027.0	15.7	65.8	61.6	1000.0	12.8
44.0	77.7	46.9	1092.0	19.9	73.0	53.8	1060.0	16.3	68.4	61.5	1030.0	13.3
46.0	80.7	46.9	1128.0	20.6	75.9	53.8	1093.0	16.9	71.0	61.4	1062.0	13.9
48.0	83.7	46.9	1164.0	21.4	78.7	53.7	1128.0	17.6	73.8	61.4	1094.0	14.4
50.0	86.9	46.9	1202.0	22.2	81.7	53.7	1164.0	18.3	76.6	61.3	1128.0	15.0

MODEL: YCWL0084HE											IPLV= 25.1	
ENTERING CONDENSER WATER TEMPERATURE (°F)												
LCWT (°F)	75.0				85.0				95.0			
	TONS	KW	MBH	EER	TONS	KW	MBH	EER	TONS	KW	MBH	EER
40.0	81.6	50.5	1151.0	19.4	76.2	59.2	1116.0	15.4	71.0	69.1	1088.0	12.3
42.0	84.9	50.2	1190.0	20.3	79.3	58.9	1152.0	16.2	73.9	68.7	1121.0	12.9
44.0	88.4	49.8	1230.0	21.3	82.4	58.5	1189.0	16.9	76.8	68.3	1155.0	13.5
46.0	91.9	49.5	1271.0	22.3	85.7	58.1	1227.0	17.7	79.9	67.9	1190.0	14.1
48.0	95.5	49.1	1314.0	23.3	89.2	57.8	1267.0	18.5	83.0	67.5	1227.0	14.8
50.0	99.2	48.8	1357.0	24.4	92.7	57.5	1308.0	19.4	86.3	67.2	1265.0	15.4

MODEL: YCWL0094HE											IPLV= 25.3	
ENTERING CONDENSER WATER TEMPERATURE (°F)												
LCWT (°F)	75.0				85.0				95.0			
	TONS	KW	MBH	EER	TONS	KW	MBH	EER	TONS	KW	MBH	EER
40.0	91.4	56.1	1288.0	19.5	85.9	65.6	1254.0	15.7	80.2	76.5	1224.0	12.6
42.0	94.9	55.8	1328.0	20.4	89.2	65.2	1292.0	16.4	83.4	76.1	1260.0	13.1
44.0	98.5	55.4	1371.0	21.3	92.6	64.8	1332.0	17.1	86.6	75.7	1297.0	13.7
46.0	102.2	55.1	1414.0	22.3	96.1	64.5	1372.0	17.9	89.9	75.2	1335.0	14.3
48.0	106.0	54.8	1458.0	23.2	99.7	64.1	1414.0	18.7	93.3	74.8	1375.0	15.0
50.0	109.9	54.4	1504.0	24.2	103.4	63.7	1458.0	19.5	96.8	74.4	1415.0	15.6

## NOTES:

1. Tons = Unit Cooling Capacity Output
2. KW = Compressor Input Power
3. MBH = Condenser Heat Rejection
4. EER = Chiller Energy Efficiency Ratio
5. LCWT = Leaving Chilled Water Temperature

## Ratings - High Efficiency (Cont'd)

MODEL: YCWL0096HE											IPLV= 21.8	
ENTERING CONDENSER WATER TEMPERATURE (°F)												
LCWT (°F)	75.0				85.0				95.0			
	TONS	KW	MBH	EER	TONS	KW	MBH	EER	TONS	KW	MBH	EER
40.0	93.8	61.3	1334.0	18.4	89.1	68.5	1302.0	15.6	84.0	76.4	1268.0	13.2
42.0	97.2	61.6	1377.0	18.9	92.4	68.8	1343.0	16.1	87.1	76.6	1306.0	13.6
44.0	100.8	62.0	1420.0	19.5	95.8	69.1	1385.0	16.6	90.3	76.9	1346.0	14.1
46.0	104.4	62.4	1465.0	20.1	99.3	69.5	1428.0	17.1	93.7	77.2	1387.0	14.6
48.0	108.1	62.9	1511.0	20.6	102.8	69.9	1472.0	17.6	97.1	77.6	1429.0	15.0
50.0	111.9	63.4	1559.0	21.2	106.5	70.4	1518.0	18.1	100.6	78.0	1473.0	15.5

MODEL: YCWL0118HE											IPLV= 24.9	
ENTERING CONDENSER WATER TEMPERATURE (°F)												
LCWT (°F)	75.0				85.0				95.0			
	TONS	KW	MBH	EER	TONS	KW	MBH	EER	TONS	KW	MBH	EER
40.0	115.7	71.3	1631.0	19.5	109.5	82.7	1596.0	15.9	102.8	96.0	1561.0	12.8
42.0	119.8	71.0	1679.0	20.2	113.4	82.4	1642.0	16.5	106.6	95.6	1606.0	13.4
44.0	124.0	70.8	1729.0	21.0	117.5	82.0	1689.0	17.2	110.5	95.2	1651.0	13.9
46.0	128.3	70.5	1780.0	21.8	121.6	81.7	1738.0	17.9	114.5	94.8	1697.0	14.5
48.0	132.8	70.3	1833.0	22.7	125.9	81.4	1788.0	18.6	118.5	94.4	1745.0	15.1
50.0	137.4	70.1	1887.0	23.5	130.2	81.1	1839.0	19.3	122.7	94.1	1793.0	15.7

## NOTES:

1. Tons = Unit Cooling Capacity Output
2. KW = Compressor Input Power
3. MBH = Condenser Heat Rejection
4. EER = Chiller Energy Efficiency Ratio
5. LCWT = Leaving Chilled Water Temperature

## Ratings - High Efficiency (Cont'd)

MODEL: YCWL0127HE											IPLV= 24.8	
ENTERING CONDENSER WATER TEMPERATURE (°F)												
LCWT (°F)	75.0				85.0				95.0			
	TONS	KW	MBH	EER	TONS	KW	MBH	EER	TONS	KW	MBH	EER
40.0	127.0	78.7	1792.0	19.4	119.5	91.7	1747.0	15.6	112.0	106.7	1708.0	12.6
42.0	131.8	78.3	1848.0	20.2	124.0	91.3	1800.0	16.3	116.2	106.2	1757.0	13.1
44.0	136.7	77.9	1906.0	21.1	128.7	90.8	1854.0	17.0	120.6	105.7	1808.0	13.7
46.0	141.8	77.5	1966.0	21.9	133.5	90.4	1910.0	17.7	125.1	105.2	1860.0	14.3
48.0	147.0	77.2	2027.0	22.9	138.4	89.9	1968.0	18.5	129.8	104.6	1914.0	14.9
50.0	152.4	76.8	2091.0	23.8	143.5	89.5	2027.0	19.2	134.6	104.2	1970.0	15.5

MODEL: YCWL0157HE											IPLV= 24.3	
ENTERING CONDENSER WATER TEMPERATURE (°F)												
LCWT (°F)	75.0				85.0				95.0			
	TONS	KW	MBH	EER	TONS	KW	MBH	EER	TONS	KW	MBH	EER
40.0	146.9	90.5	2071.0	19.5	138.5	104.2	2017.0	15.9	129.8	120.2	1968.0	13.0
42.0	152.2	90.3	2135.0	20.2	143.6	103.9	2078.0	16.6	134.7	119.7	2025.0	13.5
44.0	157.8	90.1	2200.0	21.0	148.9	103.6	2140.0	17.2	139.8	119.3	2084.0	14.1
46.0	163.4	89.9	2267.0	21.8	154.3	103.3	2204.0	17.9	144.9	118.9	2145.0	14.6
48.0	169.2	89.7	2336.0	22.6	159.8	103.0	2269.0	18.6	150.2	118.5	2206.0	15.2
50.0	175.1	89.5	2406.0	23.5	165.5	102.7	2336.0	19.3	155.6	118.1	2270.0	15.8

## NOTES:

1. KW<sub>o</sub> = Unit kW Cooling Capacity Output
2. KW<sub>i</sub> = Compressor kW Input
3. KW = Condenser Heat Rejection
4. COP = Coefficient of Performance
5. LCWT = Leaving Chilled Water Temperature
6. Ratings based on 0.047 l/s cooler water per kW.

# Part Load Ratings – English

## STANDARD EFFICIENCY (SE)

YCWL0056SE			
% LOAD	TONS	KW	EER
100.0	51.6	37.9	16.3
75.0	40.4	25.6	19.0
50.0	28.4	15.1	22.5
25.0	13.9	7.3	23.0
IPLV = 21.3			

YCWL0064SE			
% LOAD	TONS	KW	EER
100.0	59.9	45.7	15.7
75.0	47.1	31.1	18.2
50.0	33.3	19.1	20.9
25.0	16.3	9.2	21.2
IPLV = 19.9			

YCWL0074SE			
% LOAD	TONS	KW	EER
100.0	67.8	53.6	15.2
72.2	52.5	34.1	18.5
50.0	38.7	21.8	21.2
22.2	16.2	9.2	21.2
IPLV = 20.2			

YCWL0084SE			
% LOAD	TONS	KW	EER
100.0	76.6	58.3	15.8
75.0	61.0	37.7	19.4
50.0	44.4	22.3	23.9
25.0	21.9	10.5	25.0
IPLV = 22.5			

YCWL0094SE			
% LOAD	TONS	KW	EER
100.0	85.9	63.8	16.2
72.6	66.6	39.5	20.3
50.0	47.8	24.2	23.7
22.6	21.9	10.5	25.1
IPLV = 22.6			

YCWL0104SE			
% LOAD	TONS	KW	EER
100.0	92.8	68.9	16.2
75.0	72.6	44.2	19.7
50.0	50.9	26.2	23.3
25.0	24.9	12.6	23.8
IPLV = 23.0			

YCWL0118SE			
% LOAD	TONS	KW	EER
100.0	110.5	84.9	15.6
71.8	85.7	50.9	20.2
50.0	62.7	30.1	25.0
21.8	27.0	12.0	26.9
IPLV = 23.5			

YCWL0132SE			
% LOAD	TONS	KW	EER
100.0	127.4	94.7	16.1
75.0	100.2	61.0	19.7
50.0	70.8	33.7	25.2
25.0	34.7	15.9	26.2
IPLV = 23.4			

YCWL0157SE			
% LOAD	TONS	KW	EER
100.0	144.0	104.7	16.5
75.0	113.5	68.1	20.0
50.0	80.2	38.0	25.3
25.0	39.3	17.9	26.3
IPLV = 23.5			

YCWL0177SE			
% LOAD	TONS	KW	EER
100.0	167.7	118.0	17.0
76.2	141.9	81.5	20.9
61.9	108.6	53.8	24.2
38.1	72.7	32.4	26.9
23.8	35.2	16.3	25.9
IPLV = 24.5			

YCWL0198SE			
% LOAD	TONS	KW	EER
100.0	199.6	143.3	16.7
83.3	172.9	107.8	19.2
66.7	144.8	77.0	22.6
50.0	110.0	52.0	25.4
33.3	72.3	33.2	26.1
16.7	35.2	16.7	25.4
IPLV = 24.0			

## HIGH EFFICIENCY (HE)

YCWL0064HE			
% LOAD	TONS	KW	EER
100.0	63.2	46.3	16.4
75.0	49.0	30.8	19.1
50.0	33.5	17.5	23.0
25.0	16.3	8.3	23.5
IPLV = 21.5			

YCWL0074HE			
% LOAD	TONS	KW	EER
100.0	73.0	53.8	16.3
75.0	55.1	32.5	20.3
50.0	39.4	19.1	24.8
25.0	16.2	8.3	23.6
IPLV = 22.7			

YCWL0084HE			
% LOAD	TONS	KW	EER
100.0	82.4	58.5	16.9
75.0	64.7	37.3	20.9
50.0	45.5	20.0	27.3
25.0	22.4	9.4	28.7
IPLV = 25.1			

YCWL0094HE			
% LOAD	TONS	KW	EER
100.0	92.6	64.8	17.1
75.0	70.9	38.8	21.9
50.0	50.6	22.5	27.0
25.0	22.5	9.2	29.2
IPLV = 25.3			

YCWL0096HE			
% LOAD	TONS	KW	EER
100.0	94.6	68.0	16.7
83.3	80.9	53.1	18.3
66.7	66.2	39.9	19.9
50.0	50.0	28.3	21.2
33.3	34.2	18.8	21.8
16.7	16.5	9.2	21.6
IPLV = 20.5			

YCWL0118HE			
% LOAD	TONS	KW	EER
100.0	117.2	83.1	16.9
71.8	89.7	49.7	21.7
50.0	64.4	29.4	26.3
21.8	27.7	11.9	27.9
IPLV = 24.7			

YCWL0127HE			
% LOAD	TONS	KW	EER
100.0	132.1	93.7	16.9
83.7	113.6	70.6	19.3
58.1	82.2	41.7	23.7
41.9	58.9	27.0	26.2
16.3	22.7	10.5	25.9
IPLV = 23.7			

YCWL0157HE			
% LOAD	TONS	KW	EER
100.0	148.5	104.3	17.1
75.0	116.8	67.2	20.9
50.0	81.4	37.7	25.9
25.0	39.9	17.8	26.9
IPLV = 24.2			

## Part Load Ratings – SI

### STANDARD EFFICIENCY (SE)

YCWL0056SE			
% LOAD	KWO	KWI	COP
100.0	182.4	38.1	4.8
75.0	142.9	25.6	5.6
50.0	100.3	15.1	6.6
25.0	49.3	7.3	6.8
IPLV = 6.3			

YCWL0064SE			
% LOAD	KWO	KWI	COP
100.0	210.7	45.7	4.6
75.0	165.6	31.1	5.3
50.0	117.0	19.1	6.1
25.0	57.3	9.2	6.2
IPLV = 5.8			

YCWL0074SE			
% LOAD	KWO	KWI	COP
100.0	238.5	53.6	4.4
72.2	184.8	34.1	5.4
50.0	136.0	21.8	6.2
22.2	57.1	9.2	6.2
IPLV = 5.9			

YCWL0084SE			
% LOAD	KWO	KWI	COP
100.0	269.3	58.3	4.6
75.0	214.5	37.7	5.7
50.0	156.0	22.3	7.0
25.0	77.1	10.5	7.3
IPLV = 6.6			

YCWL0094SE			
% LOAD	KWO	KWI	COP
100.0	302.0	63.8	4.7
72.6	234.4	41.6	5.6
50.0	167.9	25.4	6.6
22.6	77.0	11.0	7.0
IPLV = 6.3			

YCWL0104SE			
% LOAD	KWO	KWI	COP
100.0	326.5	68.9	4.7
75.0	255.5	46.5	5.5
50.0	179.1	27.6	6.5
25.0	87.6	13.2	6.6
IPLV = 6.1			

YCWL0118SE			
% LOAD	KWO	KWI	COP
100.0	388.5	84.9	4.6
71.0	301.3	50.9	5.9
50.0	220.6	30.1	7.3
21.0	95.1	12.0	7.9
IPLV = 6.9			

YCWL0132SE			
% LOAD	KWO	KWI	COP
100.0	448.0	94.7	4.7
75.0	352.4	61.0	5.8
50.0	248.9	33.7	7.4
25.0	122.1	15.9	7.7
IPLV = 6.9			

YCWL0157SE			
% Load	kWo	kWi	COP
100.0	506.4	104.7	4.8
75.0	399.2	68.1	5.9
50.0	282.1	38.0	7.4
25.0	138.1	17.9	7.7
IPLV = 6.9			

YCWL0177SE			
% LOAD	KWo	KWi	COP
100.0	592.7	118.0	5.0
76.2	502.8	80.6	6.2
61.9	384.3	53.3	7.2
38.1	257.4	32.2	8.0
23.8	124.9	16.1	7.7
IPLV = 7.3			

YCWL0198SE			
% LOAD	KWo	KWi	COP
100.0	705.4	143.3	4.9
83.3	613.4	106.7	5.8
66.7	512.8	76.3	6.7
50.0	389.6	51.6	7.6
33.3	256.3	32.9	7.9
16.7	125.2	16.5	7.6
IPLV = 7.2			

### HIGH EFFICIENCY (HE)

YCWL0064HE			
% LOAD	KWO	KWI	COP
100.0	222.8	46.5	4.8
75.0	172.7	30.8	5.6
50.0	118.3	17.4	6.8
25.0	57.9	8.3	7.0
IPLV = 6.4			

YCWL0074HE			
% LOAD	KWO	KWI	COP
100.0	257.2	54.0	4.8
75.0	194.0	32.5	6.0
50.0	139.3	19.0	7.3
25.0	57.6	8.3	7.0
IPLV = 6.7			

YCWL0084HE			
% LOAD	KWO	KWI	COP
100.0	290.3	58.8	4.9
75.0	228.2	37.3	6.1
50.0	160.8	19.9	8.1
25.0	79.6	9.3	8.5
IPLV = 7.4			

YCWL0094HE			
% LOAD	KWO	KWI	COP
100.0	326.1	65.2	5.0
75.0	249.7	38.9	6.4
50.0	173.7	22.4	8.0
25.0	79.8	9.2	8.7
IPLV = 7.5			

YCWL0096HE			
% LOAD	KWO	KWI	COP
100.0	332.6	68.0	4.9
83.3	284.4	53.1	5.4
66.7	232.7	39.9	5.8
50.0	176.0	28.3	6.2
33.3	117.7	18.6	6.3
16.7	56.6	9.0	6.3
IPLV = 6.0			

YCWL0118HE			
% LOAD	KWO	KWI	COP
100.0	412.0	83.1	5.0
71.0	315.4	49.7	6.4
50.0	226.5	29.4	7.7
21.0	97.3	11.9	8.2
IPLV = 7.2			

YCWL0127HE			
% LOAD	KWO	KWI	COP
100.0	464.6	93.7	5.0
83.7	399.6	70.6	5.7
58.1	289.0	41.7	6.9
41.9	207.1	27.0	7.7
16.3	79.7	10.5	7.6
IPLV = 6.9			

YCWL0157HE			
% LOAD	KWO	KWI	COP
100.0	522.2	104.3	5.0
75.0	410.6	67.2	6.1
50.0	286.3	37.7	7.6
25.0	140.4	17.8	7.9
IPLV = 7.1			

# Physical Data – English

## STANDARD EFFICIENCY (SE)

YCWL	0056SE	0064SE	0074SE	0084SE	0094SE	0104SE	0118SE	0132SE	0157SE	0177SE	0198SE
<b>GENERAL UNIT DATA</b>											
Nominal Unit Capacity (Tons)	51.6	59.9	67.8	76.6	85.8	92.7	110.4	127.4	144.0	167.7	199.6
Number of Independent Refrigerant Circuits	2	2	2	2	2	2	2	2	2	2	2
Refrigerant Charge, R-410A, Ckt 1/Ckt. 2 (lbs.)	60/ 60	60/ 60	60/ 60	70/ 70	65/ 65	80/ 80	80/ 80	130/ 130	170/ 170	195/ 195	195/ 195
Oil Charge, Ckt. 1/Ckt. 2, (gal.)	1.7/ 1.7	2.2/ 2.2	2.5/ 2.2	2.5/ 2.5	3.1/ 2.5	3.1/ 3.1	3.3/ 3.1	3.3/ 3.3	4.7/ 4.7	4.7/ 4.7	4.7/ 4.7
Shipping Weight (lbs.)	3723	3883	4061	4489	5023	5157	5155	5603	7189	7318	7673
Operating Weight (lbs.)	3856	4016	4194	4684	5338	5472	5470	6167	7917	8262	8617
<b>COMPRESSORS, SCROLL</b>											
Quantity per Chiller	4	4	4	4	4	4	4	4	4	5	6
Nominal Size Ckt. 1/ Ckt. 2	13-13/ 13-13	15-15/ 15-15	20-20/ 15-15	20-20/ 20-20	25-25/ 20-20	25-25/ 25-25	32-32/ 25-25	32-32/ 32-32	35-35/ 35-35	32-32- 32/ 32- 32	32-32- 32/ 32- 32-32
<b>CONDENSER</b>											
Water Volume (gal.)	19.4	19.4	19.4	26.9	26.9	26.9	26.9	35.2	52.4	59.1	59.1
Maximum Water Side Pressure (psig)	150	150	150	150	150	150	150	150	150	150	150
Maximum Refrigerant Side Pressure (psig)	560	560	560	560	560	560	560	560	560	560	560
Dia. X Length (inches X feet)	13" x 8'	13" x 8'	13" x 8'	14" x 8'	14" x 8'	14" x 8'	14" x 8'	16" x 8'	18" x 10'	18"x10'	18"x10'
Water Nozzle Connection Size, (inches)	4	4	4	4	4	4	4	5	5	5	5
<b>EVAPORATOR</b>											
Water Volume (gals.)	22.4	22.4	22.4	22.4	37.3	37.3	37.3	59.8	57.6	77.0	77.0
Maximum Water Side Pressure (psig)	150	150	150	150	150	150	150	150	150	150	150
Maximum Refrigerant Side Pressure (psig)	450	450	450	450	450	450	450	450	450	450	450
Dia. X Length (inches X feet)	11" x 8'	11" x 8'	11" x 8'	11" x 8'	13" x 8'	14" x 8'	14" x 8'	16" x 8'	15" x 10'	17" x 10'	17" x 10'
Water Nozzle Connection Size, (inches)	6	6	6	6	6	6	6	8	8	8	8

## Physical Data – English (Cont'd)

### HIGH EFFICIENCY (HE)

YCWL	0064HE	0074HE	0084HE	0094HE	0096HE	0118HE	0127HE	0157HE
<b>GENERAL UNIT DATA</b>								
Nominal Unit Capacity (Tons)	63.2	73	82.4	92.6	95.8	117.2	132.1	148.5
Number of Independent Refrigerant Circuits	2	2	2	2	2	2	2	2
Refrigerant Charge, R-410A, Ckt 1/Ckt. 2 (lbs.)	65/65	90/90	90/90	155/155	170/170	155/155	180/180	195/195
Oil Charge, Ckt. 1/Ckt. 2, (gal.)	2.2/2.2	2.5/2.2	2.5/2.5	3.1/2.5	3.3/3.3	3.3/3.1	3.7/3.7	4.7/4.7
Shipping Weight (lbs.)	4373	4835	5097	5669	6013	5905	7087	6863
Operating Weight (lbs.)	4688	5330	5592	6308	6741	6544	7975	7807
<b>COMPRESSORS, SCROLL</b>								
Quantity per Chiller	4	4	4	4	6	4	5	4
Nominal Size Ckt. 1/ Ckt. 2	15-15/ 15-15	20-20/ 15-15	20-20/ 20-20	25-25/ 20-20	15-15-15/ 15-15-15	32-32/ 25-25	20-20-20/ 32-32	35-35/ 35-35
<b>CONDENSER</b>								
Water Volume (gal.)	26.9	26.9	26.9	44.1	52.4	44.1	52.4	59.1
Maximum Water Side Pressure (psig)	150	150	150	150	150	150	150	150
Maximum Refrigerant Side Pressure (psig)	560	560	560	560	560	560	560	560
Dia. X Length (inches X feet)	14" x 8'	14" x 8'	14" x 8'	18" x 8'	18" x 10'	18" x 8'	18" x 10'	18" x 10'
Water Nozzle Connection Size, (inches)	4	4	4	5	5	5	5	5
<b>EVAPORATOR</b>								
Water Volume (gals.)	37.3	59.8	59.8	59.8	57.6	59.8	77	77
Maximum Water Side Pressure (psig)	150	150	150	150	150	150	150	150
Maximum Refrigerant Side Pressure (psig)	450	450	450	450	450	450	450	450
Dia. X Length (inches X feet)	13" x 8'	16" x 8'	16" x 8'	16" x 8'	15" x 10'	16" x 8'	17" x 10'	17" x 10'
Water Nozzle Connection Size, (inches)	6	8	8	8	8	8	8	8

# Physical Data – Standard & High Efficiency – SI

## STANDARD EFFICIENCY (SE)

YCWL	0056SE	0064SE	0074SE	0084SE	0094SE	0104SE	0118SE	0132SE	0157SE	0177SE	0198SE
<b>GENERAL UNIT DATA</b>											
Unit Capacity at 44°F water & 95°F ambient (kW)	182.4	210.6	238.4	269.3	301.7	325.9	388.5	448.0	506.4	589.3	701.4
Number of Independent Refrigerant Circuits	2	2	2	2	2	2	2	2	2	2	2
Refrigerant Charge, R-410A, Ckt.-1/Ckt.-2 (kg)	27.2/ 27.2	27.2/ 27.2	27.2/ 27.2	31.8/ 31.8	29.5/ 29.5	36.3/ 36.3	36.3/ 36.3	59/ 59	77.1/ 77.1	77/ 77	77/ 77
Oil Charge, Ckt.-1/Ckt.-2 (liters)	6.4/ 6.4	8.3/ 8.3	9.5/ 8.3	9.5/ 9.5	11.7/ 9.5	11.7/ 11.7	12.5/ 11.7	12.5/ 12.5	17.8/ 17.8	17.7/ 17.7	17.7/ 17.7
Shipping Weight (kg)	1689	1761	1842	2036	2278	2339	2338	2541	3261	3319	3480
Operating Weight (kg)	1749	1821	1902	2125	2421	2482	2481	2797	3591	3747	3908
<b>COMPRESSORS, SCROLL</b>											
Quantity per Chiller	4	4	4	4	4	4	4	4	4	5	6
Nominal Size Ckt. 1/ Ckt. 2	10-10/ 10-10	11-11/ 11-11	15-15/ 11-11	15-15/ 15-15	19-19/ 15-15	19-19/ 19-19	24-24/ 19-19	24-24/ 24-24	26-26/ 26-26	24-24- 24/ 24-24	24-24- 24/ 24-24- 24
<b>CONDENSER</b>											
Water Volume (liters)	73.4	73.4	73.4	101.8	101.8	101.8	101.8	133.2	198.4	223	223
Maximum Water Side Pressure (kPa)	10.3	10.3	10.3	10.3	10.3	10.3	10.3	10.3	10.3	10.3	10.3
Maximum Refrigerant Side Pressure (kPa)	38.6	38.6	38.6	38.6	38.6	38.6	38.6	38.6	38.6	38.6	38.6
Dia. X Length (mm x m)	330 x 2.4	330 x 2.4	330 x 2.4	356 x 2.4	356 x 2.4	356 x 2.4	356 x 2.4	406 x 2.4	457 x 3.0	460 X 3	460 X 3
Water Nozzle Connection Size, (mm)	101.6	101.6	101.6	101.6	101.6	101.6	101.6	127	127	5	5
<b>EVAPORATOR</b>											
Water Volume (liters)	84.8	84.8	84.8	84.8	141.2	141.2	141.2	226.4	218.0	291.0	291.0
Maximum Water Side Pressure (kPa)	10.3	10.3	10.3	10.3	10.3	10.3	10.3	10.3	10.3	10.3	10.3
Maximum Refrigerant Side Pressure (kPa)	31.0	31.0	31.0	31.0	31.0	31.0	31.0	31.0	31.0	31.0	31.0
Dia. X Length (mm x m)	279 x 2.4	279 x 2.4	279 x 2.4	279 x 2.4	330 x 2.4	356 x 2.4	356 x 2.4	406 x 2.4	381 x 3.0	43 X 3	43 X 3
Water Nozzle Connection Size, in.	6	6	6	6	6	6	6	8	8	8	8



## Physical Data – SI (Cont'd)

### HIGH EFFICIENCY (HE)

YCWL	0064HE	0074HE	0084HE	0094HE	0096HE	0118HE	0127HE	0157HE
<b>GENERAL UNIT DATA</b>								
Unit Capacity at 44°F water & 95°F ambient (kW)	222.8	257.2	290.3	326.1	337.8	413.3	465.8	523.6
Number of Independent Refrigerant Circuits	2	2	2	2	2	2	2	2
Refrigerant Charge, R-410A, Ckt.-1/Ckt.-2 (kg)	29.5/29.5	40.9/40.9	40.9/40.9	70.3/70.3	77.1/77.1	70.3/70.3	81.6/81.6	88.5/88.5
Oil Charge, Ckt.-1/Ckt.-2 (liters)	8.3/8.3	9.5/8.3	9.5/9.5	11.7/9.5	12.5/12.5	12.5/11.7	14/14	17.8/17.8
Shipping Weight (kg)	1984	2193	2312	2571	2727	2678	3215	3113
Operating Weight (kg)	2126	2418	2536	2861	3058	2968	3617	3541
<b>COMPRESSORS, SCROLL</b>								
Quantity per Chiller	4	4	4	4	6	4	5	4
Nominal Size Ckt. 1/ Ckt. 2	11-11/ 11-11	15-15/ 11-11	15-15/ 15-15	19-19/ 15-15	11-11-11/ 11-11-11	24-24/ 19-19	15-15-15/ 23-23	26-26/ 26-26
<b>CONDENSER</b>								
Water Volume (liters)	101.8	101.8	101.8	166.9	198.4	166.9	198.4	223.7
Maximum Water Side Pressure (kPa)	10.3	10.3	10.3	10.3	10.3	10.3	10.3	10.3
Maximum Refrigerant Side Pressure (kPa)	38.6	38.6	38.6	38.6	38.6	38.6	38.6	38.6
Dia. X Length (mm x m)	356 x 2.4	356 x 2.4	356 x 2.4	457 x 2.4	457 x 3.0	457 x 2.4	457 x 3.0	457 x 3.0
Water Nozzle Connection Size, (mm)	101.6	101.6	101.6	127	127	127	127	127
<b>EVAPORATOR</b>								
Water Volume (liters)	141.2	226.4	226.4	226.4	218	226.4	291.5	291.5
Maximum Water Side Pressure (kPa)	10.3	10.3	10.3	10.3	10.3	10.3	10.3	10.3
Maximum Refrigerant Side Pressure (kPa)	31.0	31.0	31.0	31.0	31.0	31.0	31.0	31.0
Dia. X Length (mm x m)	330 x 2.4	406 x 2.4	406 x 2.4	406 x 2.4	381 x 3.0	406 x 2.4	432 x 3.0	432 x 3.0
Water Nozzle Connection Size, (mm)	6	8	8	8	8	8	8	8

# Isolator Selection Data

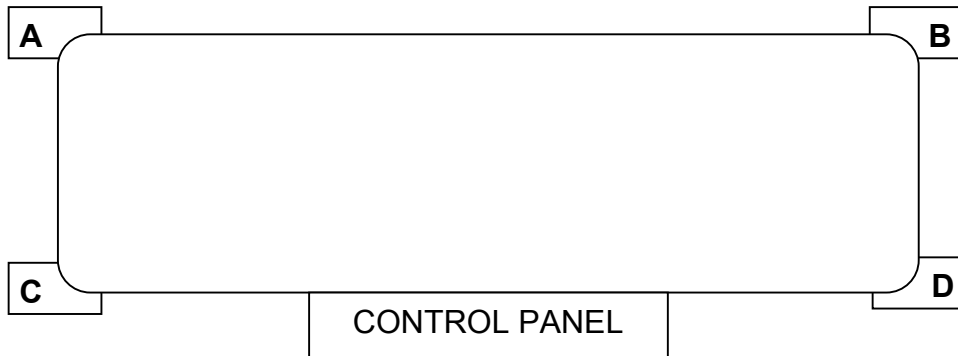

MODEL YCWL	EFFICIENCY	ELASTOMERIC ISOLATOR	1" DEFLECTION ISOLATOR	SEISMIC ISOLATOR
0056	SE	RD-4 Brick Red	CP-1D-1360 White	Red/Black
0064	SE	RD-4 Brick Red	CP-1D-1360 White	Pink
0074	SE	RD-4 Brick Red	CP-1D-1785N Gray/Red	Pink
0084	SE	RD-4 Brick Red	CP-2D-1800 Dark Green	Pink
0094	SE	RD-4 Brick Red	CP-2D-1800 Dark Green	Pink
0104	SE	RD-4 Brick Red	CP-2D-1800 Dark Green	Pink
0118	SE	RD-4 Brick Red	CP-2D-1800 Dark Green	Pink
0132	SE	RD-4 Brick Red	C2P-1D-2400 Gray	Pink/Gray
0157	SE	RD-4 Charcoal	C2P-1D-2720 White	Pink/Gray/Orange
0177	SE	RD-4 Charcoal	C2P-1D-2720 White	Pink/Gray
0198	SE	RD-4 Charcoal	C2P-1D-3570 Gray/Red	Pink/Gray/Orange
0064	HE	RD-4 Brick Red	CP-1D-1785N Gray/Red	Pink
0074	HE	RD-4 Brick Red	CP-2D-1800 Dark Green	Pink
0084	HE	RD-4 Brick Red	CP-2D-1800 Dark Green	Pink/Gray
0094	HE	RD-4 Charcoal	C2P-1D-2400 Gray	Pink/Gray
0096	HE	RD-4 Charcoal	C2P-1D-2400 Gray	Pink/Gray
0118	HE	RD-4 Charcoal	C2P-1D-2400 Gray	Pink/Gray
0127	HE	RD-4 Charcoal	C2P-1D-2720 White	Pink/Gray
0157	HE	RD-4 Charcoal	C2P-1D-3570 Gray/Red	Pink/Gray/Orange

Note: All four corners use the same isolator

# Isolator Information

## ELASTOMERIC ISOLATOR

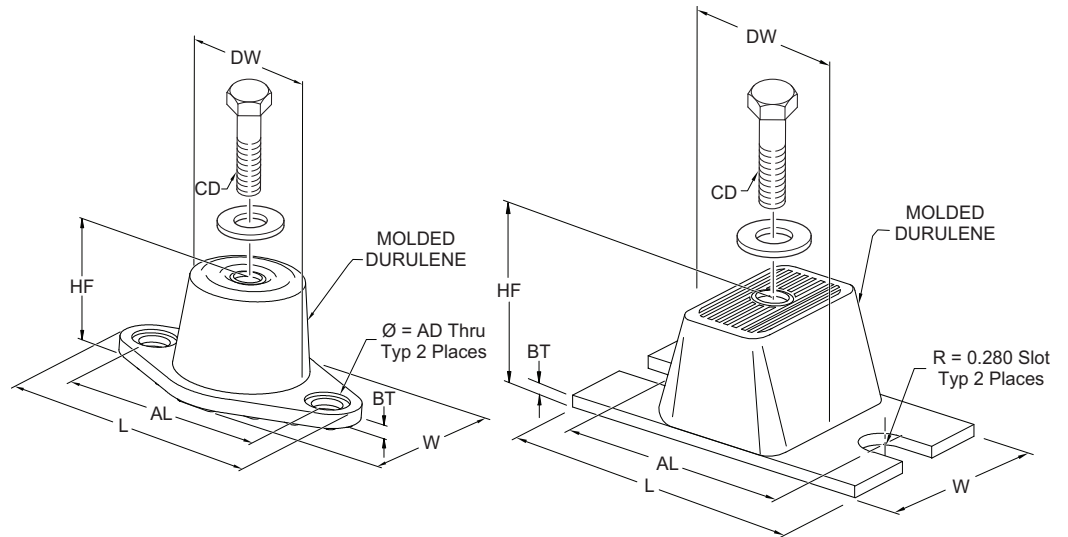

LD17304

MOUNT TYPE	DIMENSION DATA (INCHES)							
	L	W	HF	AL	AD	BT	CD	DW
<b>RD1-WR</b>	3.13	1.75	1.25	2.38	0.34	0.19	5/16-18 UNC X 3/4	1.25
<b>RD2-WR</b>	3.88	2.38	1.75	3.00	0.34	0.22	3/8-16 UNC X 1	1.75
<b>RD3-WR</b>	5.50	3.38	2.88	4.13	0.56	0.25	1/2-13 UNC X 1	2.50
<b>RD4-WR</b>	6.25	4.63	2.75	5.00	0.56	0.38	1/2-13 UNC X 1	3.00

MODEL NUMBER	ISOLATOR COLOR	WEIGHT RANGE (LBS)	WEIGHT RANGE (KGS)
RD-3-CHARCOAL-WR	CHARCOAL	Up thru 825	UP TO 374
RD-4-BRICK RED-WR	BRICK RED	826 thru 1688	375 - 766
RD-4-CHARCOAL-WR	CHARCOAL	1689 thru 4000	767 - 1814

# Isolator Information (Cont'd)

## ONE INCH DEFLECTION SPRING ISOLATOR

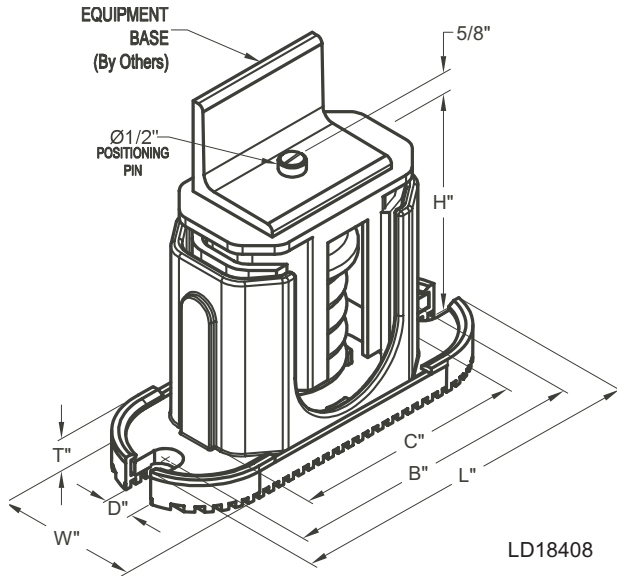

LD18408

MOUNT TYPE	DIMENSION DATA (INCHES)						
	W	D	L	B	C	T	H
CP	3	5/8	7-3/4	6-1/2	4-3/4	1/2	5-5/8
C2P	3	5/8	10-1/2	9-1/4	7-3/4	9/16	6

MODEL NUMBER	COLOR CODE	RATED CAPACITY (FOR UNITS WITH ALL LOAD POINTS LESS THAN 1785 LBS (810 KG))	
		LBS.	KG
CP-1D-510	BLACK	Up thru 434	Up thru 197
CP-1D-900	DARK GREEN	435 thru 765	198 thru 347
CP-1D-1200	GRAY	766 thru 1020	348 thru 463
CP-1D-1360	WHITE	1021 thru 1156	464 thru 524
CP-1D-1785N	GRAY/RED	1157 thru 1785	525 thru 810

MODEL NUMBER	COLOR CODE	RATED CAPACITY (FOR UNITS WITH ANY LOAD POINT ABOVE 1518 LBS (689 KG))	
		LBS.	KG
C2P-1D-1350	DARK PURPLE	Up thru 1148	Up to 521
C2P-1D-1350	DARK PURPLE	Up thru 1148	Up to 521
C2P-1D-1800	DARK GREEN	1149 thru 1530	522 - 694
C2P-1D-2400	GRAY	1531 thru 2040	695 - 925
C2P-1D-2400	GRAY	1531 thru 2040	695 - 925
C2P-1D-2720	WHITE	2041 thru 2312	926 - 1049
C2P-1D-3570N	GRAY/RED	2313 thru 3570	1050 - 1619

## Isolator Information (Cont'd)

### TWO INCH DEFLECTION, SEISMIC SPRING ISOLATOR

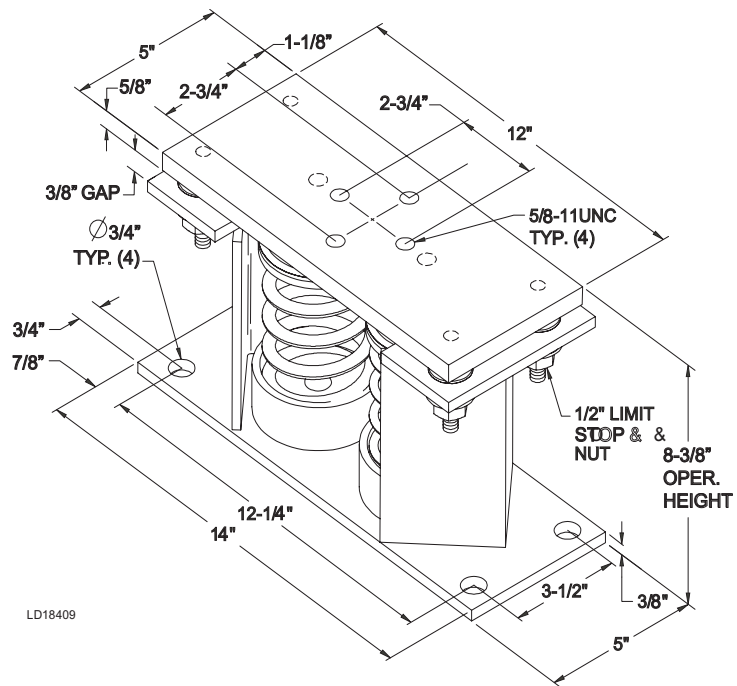

MODEL NUMBER	ISOLATOR COLOR	WEIGHT RANGE (LBS)	WEIGHT RANGE (KGS)
Y2RSI-2D-460	GREEN	Up thru 391	UP TO 177
Y2RSI-2D-460	GREEN	Up thru 391	UP TO 177
Y2RSI-2D-710	DARK BROWN	392 thru 604	178 - 274
Y2RSI-2D-870	RED	605 thru 740	275 - 336
Y2RSI-2D-1200N	RED/BLACK	741 thru 1020	337 - 463
Y2RSI-2D-1690	PINK	1021 thru 1437	464 - 652
Y2RSI-2D-2640N	PINK/GRAY	1438 thru 2244	653 - 1018
Y2RSI-2D-2870N	PINK/GRAY/ORANGE	2245 thru 2618	1019 - 1188
Y2RSI-2D-3280N	PINK/GRAY/DK.BROWN	2619 thru 3740	1189 - 1696

# Sound Data

60 HZ MODELS, BASE UNITS									
STANDARD EFFICIENCY	ARI 575 SOUND PRESSURE LEVELS (DB RE: 20 MICROPASCALS)								
	63	125	250	500	1000	2000	4000	8000	DBA
YCWL0056SE	58	47	51	67	66	65	59	55	71
YCWL0064SE	59	52	54	68	68	69	62	53	73
YCWL0074SE	60	56	64	70	70	75	68	57	78
YCWL0084SE	60	58	66	71	72	77	70	59	80
YCWL0094SE	67	61	68	74	75	76	70	58	80
YCWL0104SE	70	63	69	76	77	74	70	56	81
YCWL0118SE	42	38	57	65	68	67	66	59	73
YCWL0132SE	44	34	60	66	68	66	65	60	73
YCWL0157SE	45	33	55	65	70	73	67	58	76
YCWL0177SE	45	35	61	67	69	67	66	61	74
YCWL0198SE	45	36	62	68	69	68	67	62	74

HIGH EFFICIENCY	ARI 575 Sound Pressure Levels (dB re: 20 microPascals)								
	63	125	250	500	1000	2000	4000	8000	DBA
YCWL0064HE	59	52	54	68	68	69	62	53	73
YCWL0074HE	60	56	64	70	70	75	68	57	78
YCWL0084HE	60	58	66	71	72	77	70	59	80
YCWL0094HE	67	61	68	74	75	76	70	58	80
YCWL0096HE	61	54	55	69	70	71	64	55	75
YCWL0118HE	42	38	57	65	68	67	66	59	73
YCWL0127HE	46	36	57	67	68	68	65	59	73
YCWL0157HE	45	33	55	65	70	73	67	58	76

## Sound Data (Cont'd)

60 HZ MODELS, COMPRESSOR BLANKETS INSTALLED									
STANDARD EFFICIENCY	ARI 575 Sound Pressure Levels (dB re: 20 microPascals)								
	63	125	250	500	1000	2000	4000	8000	DBA
YCWL0056SE	58	47	50	65	61	59	53	50	66
YCWL0064SE	59	52	53	66	63	63	56	48	69
YCWL0074SE	60	56	63	68	65	69	62	52	72
YCWL0084SE	60	58	65	69	67	71	64	54	74
YCWL0094SE	67	61	67	72	70	70	64	53	75
YCWL0104SE	70	63	68	74	72	68	64	51	76
YCWL0118SE	42	38	56	63	63	61	60	54	68
YCWL0132SE	44	39	59	64	63	60	59	55	68
YCWL0157SE	45	33	54	63	65	67	61	53	71
YCWL0177SE	45	35	60	65	64	61	60	56	69
YCWL0198SE	45	36	61	66	64	62	61	57	69

HIGH EFFICIENCY	ARI 575 Sound Pressure Levels (dB re: 20 microPascals)								
	63	125	250	500	1000	2000	4000	8000	DBA
YCWL0064HE	59	52	53	66	63	63	56	48	69
YCWL0074HE	60	56	63	68	65	69	62	52	72
YCWL0084HE	60	58	65	69	67	71	64	54	74
YCWL0094HE	67	61	67	72	70	70	64	53	75
YCWL0096HE	61	54	54	67	65	65	58	50	70
YCWL0118HE	42	38	56	63	63	61	60	54	68
YCWL0127HE	46	36	56	65	63	62	59	54	68
YCWL0157HE	45	33	54	63	65	67	61	53	71

## Unit Dimensions - Four Compressor

STANDARD EFFICIENCY (SE)									
YCWL	0056SE	0064SE	0074SE	0084SE	0094SE	0104SE	0118SE	0132SE	0157SE
W	34 5/8	34 5/8	33 13/16	33 13/16	33 13/16	33 13/16	33 13/16	33 13/16	34 13/16
H	64 15/32	64 15/32	68 29/32	68 29/32	72 9/32	71 25/32	71 25/32	74 1/2	76 17/32
H*	–	–	70 1/2	70 1/2	–	73 1/2	73 1/2	–	–
H**	–	–	70 1/2	70 1/2	–	73 1/2	75	75	–
L	119 5/8	119 5/8	125 15/16	125 15/16	125 15/16	124 1/8	124 1/8	123 5/16	143 7/16
A	14 1/2	14 1/2	14 1/2	14 1/2	14 1/2	14 1/2	14 1/2	14 1/2	15
B	29	29	29	29	29	29	29	29	30
C	4 1/2	4 1/2	4 1/2	4 1/2	4 1/2	4 1/2	4 1/2	5 9/16	5 9/16
D	15 17/32	15 17/32	15 17/32	15 17/32	11 25/32	15 17/32	15 17/32	16 1/32	16 1/32
E	6 5/8	6 5/8	6 5/8	6 5/8	6 5/8	6 5/8	6 5/8	8 5/8	8 5/8
F	35 15/32	35 15/32	35 15/32	35 15/32	35 15/32	38 1/2	38 1/2	40	41
G	29	29	29	29	29	29	29	29	29
J	17 11/16	17 11/16	17 11/16	17 11/16	17 11/16	17 11/16	17 11/16	17 11/16	17 11/16
K	8 15/16	8 15/16	8 15/16	8 15/16	12 1/4	12 1/4	12 1/4	12 3/4	17 25/32
M	9 7/8	9 7/8	9 7/8	9 7/8	9 7/8	9 7/8	9 7/8	9 7/8	10 3/8
N	9 7/8	9 7/8	9 7/8	9 7/8	9 7/8	9 7/8	9 7/8	9 7/8	10 3/8
O	5 1/2	5 1/2	5 1/2	7 1/8	7 1/8	7 1/8	7 1/8	8 1/8	8 5/8
P	9 1/8	9 1/8	9 1/8	8 3/8	8 3/8	8 3/8	8 3/8	7 7/8	8 1/2
Q	5 1/8	5 1/8	5 1/8	5 1/8	5 1/8	5 1/8	5 1/8	5 7/32	5 3/16
R	84 1/2	84 1/2	84 1/2	84 1/2	85	85	85	83	102
S	8 21/32	8 21/32	8 21/32	8 21/32	8 13/32	8 13/32	8 13/32	9 13/32	11 29/32
T	101 13/16	101 13/16	101 13/16	101 13/16	101 13/16	101 13/16	101 13/16	101 13/16	125 13/16
U	15 1/16	15 1/16	21 3/8	21 3/8	21 3/8	19 9/16	19 9/16	18 3/4	14 7/8
V	107 25/32	107 25/32	107 25/32	107 25/32	107 25/32	107 25/32	107 25/32	108 7/32	132 23/32
X	30 3/8	30 3/8	30 3/8	30 3/8	32	32	32	33 1/4	36 1/4
AA	25 29/32	25 29/32	25 29/32	25 29/32	25 29/32	25 29/32	25 29/32	25 29/32	35 17/32
BB	50	50	50	50	50	50	50	50	50

HIGH EFFICIENCY (HE)						
YCWL	0064HE	0074HE	0084HE	0094HE	0118HE	0157HE
W	33 13/16	33 13/16	33 13/16	33 27/32	33 27/32	34 13/16
H	67 19/32	74 5/8	74 19/32	76 19/32	76 1/2	77 9/32
H*	–	75	75	–	77	–
H**	–	75	75	–	77	76
L	124 3/8	123 5/16	125 11/16	121 3/4	123 5/16	143 7/16
A	14 1/2	14 1/2	14 1/2	15	15	15
B	29	29	29	30	30	30
C	4 1/2	4 1/2	4 1/2	5 9/16	5 9/16	5 9/16
D	11 25/32	16 1/32	16 1/32	16 1/32	16 1/32	16 1/32
E	6 5/8	8 5/8	8 5/8	8 5/8	8 5/8	8 5/8
F	35 15/32	40	40	42	42	41
G	29	29	29	29	29	29
J	17 11/16	17 11/16	17 11/16	17 11/16	17 11/16	17 11/16
K	12 1/4	12 3/4	12 3/4	12 3/4	12 3/4	17 25/32
M	9 7/8	9 7/8	9 7/8	9 7/8	9 7/8	10 3/8
N	9 7/8	9 7/8	9 7/8	9 7/8	9 7/8	10 3/8
O	7 1/8	7 1/8	7 1/8	8 5/8	8 5/8	8 5/8
P	8 1/4	8 1/4	8 1/4	8 1/2	8 1/2	8 1/2
Q	5 1/8	5 1/8	5 1/8	5 3/16	5 3/16	5 3/16
R	85	83	83	83	83	102
S	8 13/32	9 13/32	9 13/32	9 13/32	9 13/32	11 29/32
T	101 13/16	101 13/16	101 13/16	101 13/16	101 13/16	125 13/16
U	19 13/16	18 3/4	21 1/8	17 3/16	18 3/4	14 7/8
V	107 25/32	107 25/32	107 25/32	108 3/4	108 3/4	132 23/32
X	32	33 1/4	33 1/4	35 1/4	35 1/4	36 1/4
AA	25 29/32	28 9/32	25 29/32	27 15/32	25 29/32	37 21/32
BB	50	50	50	50	50	50

H\* - for 200/230 volt units, which require a larger electrical enclosure.

H\*\* - for multiple point circuit breaker units, 200/230 volt, which require a larger electrical enclosure.



# Unit Dimensions - Four Compressor (Cont'd)

**NOTES:**

1. Recommended service clearances
  - Rear to wall: 20" (508mm)
  - Front to wall: 36" (915mm)
  - Top: 43" (1092mm)
  - Tube cleaning and removal: 132" (3353mm) either end
2. Relief valve connection sizes
  - Low side (suction line): 1/2" flare
  - High side (condenser): 5/8" NPTI

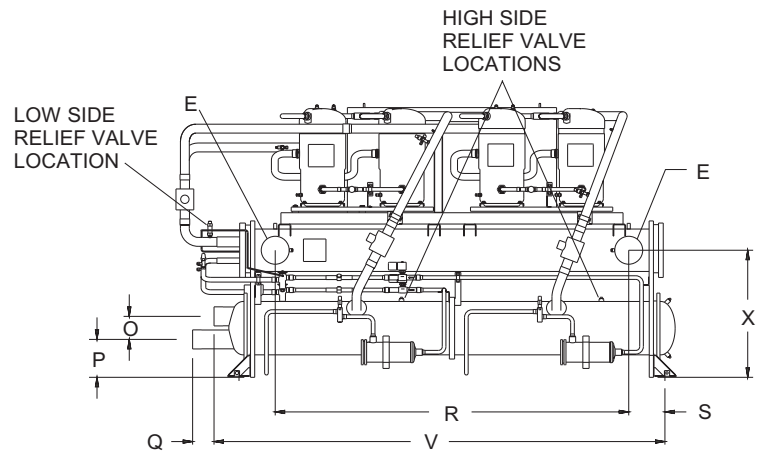
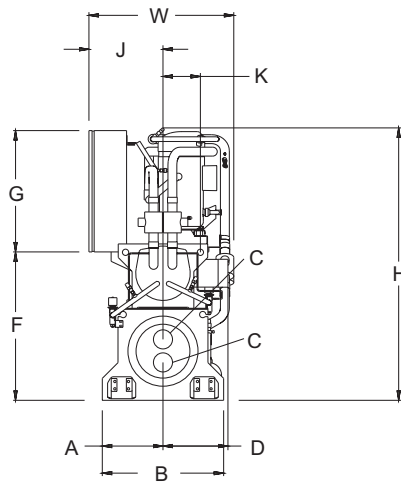
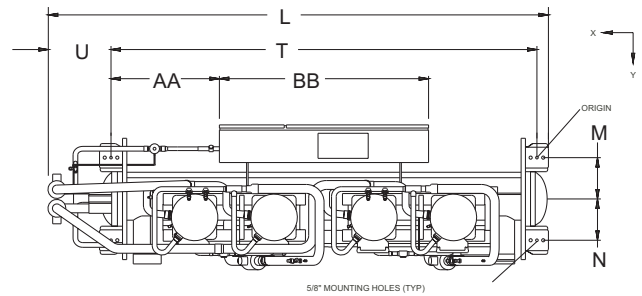

LD18410

## Unit Dimensions - Five & Six Compressor

STANDARD EFFICIENCY (SE)		
YCWL	0177SE	0198SE
W	34 13/16	34 13/16
H	77 9/32	77 9/32
H*	–	–
H**	76	76
L	143 7/16	143 7/16
A	15	15
B	30	30
C	5 9/16	5 9/16
D	16 1/32	16 1/32
E	8 5/8	8 5/8
F	41	41
G	29	29
J	17 11/16	17 11/16
K	17 25/32	17 25/32
M	10 3/8	10 3/8
N	10 3/8	10 3/8
O	8 5/8	8 5/8
P	8 1/2	8 1/2
Q	5 3/16	5 3/16
R	102	102
S	11 29/32	11 29/32
T	125 13/16	125 13/16
U	14 7/8	14 7/8
V	132 23/32	132 23/32
X	36 1/4	36 1/4
AA	37 21/32	37 21/32
BB	50	50

HIGH EFFICIENCY (HE)	
0096HE	0127HE
35 1/16	34 13/16
72 5/32	77 19/32
–	–
76	76
143 3/8	145 7/32
15	15
30	30
5 9/16	5 9/16
16 1/32	16 1/32
8 5/8	8 5/8
41	41
29	29
17 11/16	17 11/16
17 25/32	17 25/32
10 3/8	10 3/8
10 3/8	10 3/8
8 5/8	8 5/8
8 1/2	8 1/2
5 3/16	5 3/16
102	102
11 29/32	11 29/32
125 13/16	125 13/16
14 13/16	16 21/32
132 23/32	132 23/32
36 1/4	36 1/4
37 21/32	34 31/32
50	50

H\* - for 200/230 volt units, which require a larger electrical enclosure

H\*\* - for multiple point circuit breaker units, 200/230 volt, which require a larger electrical enclosure

# Unit Dimensions - Five & Six Compressor (Cont'd)

**NOTES:**

1. Recommended service clearances  
 Rear to wall: 20" (508mm)  
 Front to wall: 36" (915mm)  
 Top: 43" (1092mm)  
 Tube cleaning and removal: 132" (3353mm) either end
2. Relief valve connection sizes  
 Low side (suction line): 1/2" flare  
 High side (condenser): 5/8" NPTI

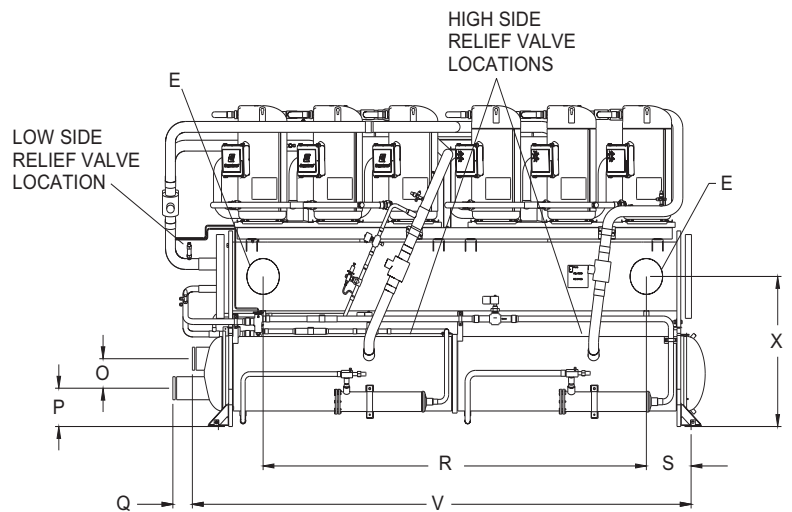
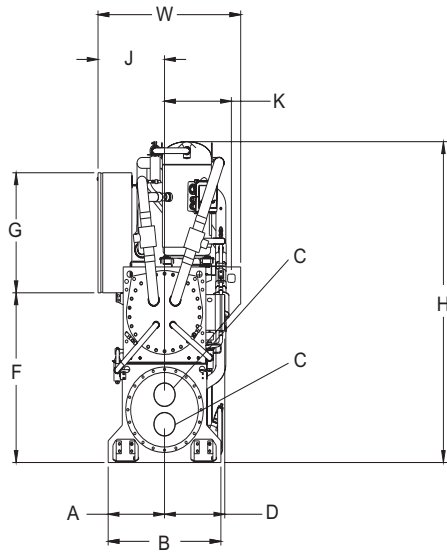
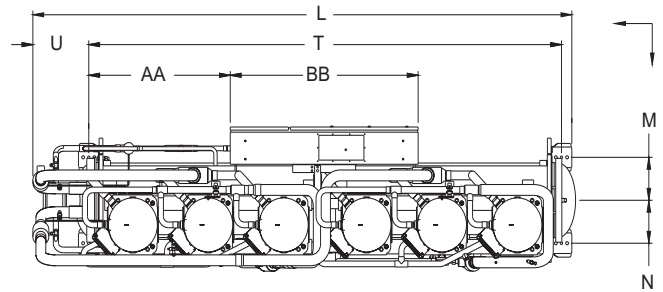

LD18411

## Unit Dimensions - SI - Four Compressor

STANDARD EFFICIENCY (SE)									
YCWL	0056SE	0064SE	0074SE	0084SE	0094SE	0104SE	0118SE	0132SE	0157SE
W	879.5	879.5	858.8	858.8	858.8	858.8	858.8	858.8	884.2
H	1637.5	1637.5	1750.2	1750.2	1835.9	1823.2	1823.2	1892.3	1943.9
H*	–	–	1790.7	1790.7	–	1866.9	1866.9	1905.0	–
H**	–	–	1790.7	1790.7	–	1866.9	1866.9	1905.0	–
L	3038.5	3038.5	3198.8	3198.8	3198.8	3152.8	3152.8	3132.1	3643.3
A	368.3	368.3	368.3	368.3	368.3	368.3	368.3	368.3	381.0
B	736.6	736.6	736.6	736.6	736.6	736.6	736.6	736.6	762.0
C	114.3	114.3	114.3	114.3	114.3	114.3	114.3	141.3	141.3
D	394.5	394.5	394.5	394.5	299.2	394.5	394.5	407.2	407.2
E	168.3	168.3	168.3	168.3	168.3	168.3	168.3	219.1	219.1
F	900.9	900.9	900.9	900.9	900.9	977.9	977.9	1016.0	1041.4
G	736.6	736.6	736.6	736.6	736.6	736.6	736.6	736.6	736.6
J	449.3	449.3	449.3	449.3	449.3	449.3	449.3	449.3	449.3
K	227.0	227.0	227.0	227.0	311.2	311.2	311.2	323.9	451.6
M	250.8	250.8	250.8	250.8	250.8	250.8	250.8	250.8	263.5
N	250.8	250.8	250.8	250.8	250.8	250.8	250.8	250.8	263.5
O	139.8	139.8	139.8	181.1	181.1	181.1	181.1	206.5	219.2
P	230.2	230.2	230.2	209.6	209.6	209.6	209.6	196.9	215.9
Q	130.2	130.2	130.2	130.2	130.2	130.2	130.2	132.6	131.8
R	2146.3	2146.3	2146.3	2146.3	2159.0	2159.0	2159.0	2108.2	2590.8
S	219.9	219.9	219.9	219.9	213.5	213.5	213.5	238.9	302.4
T	2586.1	2586.1	2586.1	2586.1	2586.1	2586.1	2586.1	2586.1	3195.7
U	382.6	382.6	542.9	542.9	542.9	496.9	496.9	476.2	377.8
V	2737.6	2737.6	2737.6	2737.6	2737.6	2737.6	2737.6	2748.8	3371.1
X	771.5	771.5	771.5	771.5	812.8	812.8	812.8	844.6	920.8
AA	658.0	658.0	658.0	658.0	658.0	658.0	658.0	658.0	902.5
BB	1270.0	1270.0	1270.0	1270.0	1270.0	1270.0	1270.0	1270.0	1270.0

HIGH EFFICIENCY (HE)					
0064HE	0074HE	0084HE	0094HE	0118HE	0157HE
858.8	858.8	858.8	859.6	859.6	884.2
1716.9	1895.5	1894.7	1945.5	1943.1	1962.9
–	1905.0	1905.0	–	1955.8	–
–	1905.0	1905.0	–	1955.8	1930.4
3159.1	3132.1	3192.5	3092.5	3132.1	3643.3
368.3	368.3	368.3	381.0	381.0	381.0
736.6	736.6	736.6	762.0	762.0	762.0
114.3	114.3	114.3	141.3	141.3	141.3
299.2	407.2	407.2	407.2	407.2	407.2
168.3	219.1	219.1	219.1	219.1	219.1
900.9	1016.0	1016.0	1066.8	1066.8	1041.4
736.6	736.6	736.6	736.6	736.6	736.6
449.3	449.3	449.3	449.3	449.3	449.3
311.2	323.9	323.9	323.9	323.9	451.6
250.8	250.8	250.8	250.8	250.8	263.5
250.8	250.8	250.8	250.8	250.8	263.5
181.1	181.1	181.1	219.2	219.2	219.2
209.6	209.6	209.6	215.9	215.9	215.9
130.2	130.2	130.2	131.8	131.8	131.8
2159.0	2108.2	2108.2	2108.2	2108.2	2590.8
213.5	238.9	238.9	238.9	238.9	302.4
2586.1	2586.1	2586.1	2586.1	2586.1	3195.7
503.2	476.2	536.6	436.5	476.2	377.8
2737.6	2737.6	2737.6	2762.3	2762.3	3371.1
812.8	844.6	844.6	895.4	895.4	920.8
658.0	718.3	658.0	697.7	658.0	956.5
1270.0	1270.0	1270.0	1270.0	1270.0	1270.0

H\* - for 200/230 volt units, which require a larger electrical enclosure.

H\*\* - for multiple point circuit breaker units, 200/230 volt, which require a larger electrical enclosure.

# Unit Dimensions - SI - Four Compressor (Cont'd)

**NOTES:**

1. Recommended service clearances
  - Rear to wall: 20" (508mm)
  - Front to wall: 36" (915mm)
  - Top: 43" (1092mm)
  - Tube cleaning and removal: 132" (3353mm) either end
2. Relief valve connection sizes
  - Low side (suction line): 1/2" flare
  - High side (condenser): 5/8" NPTI

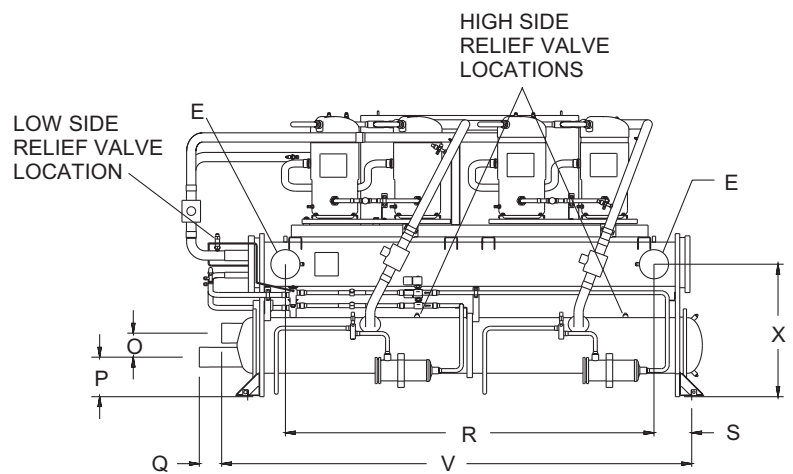
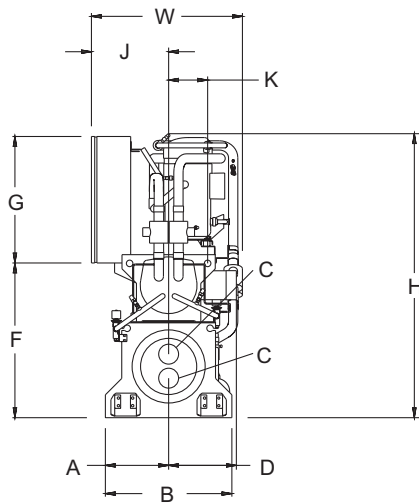
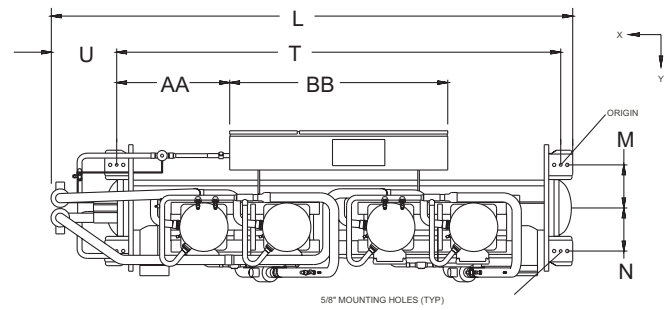

LD18410

## Unit Dimensions - SI - Five & Six Compressor

STANDARD EFFICIENCY (SE)			
YCWL	0156SE	0177SE	0198SE
W	884.2	884.2	884.2
H	1943.9	1962.9	1962.9
H*	—	—	—
H**	—	1930.4	1930.4
L	3643.3	3643.3	3643.3
A	381.0	381.0	381.0
B	762.0	762.0	762.0
C	141.3	141.3	141.3
D	407.2	407.2	407.2
E	219.1	219.1	219.1
F	1041.4	1041.4	1041.4
G	736.6	736.6	736.6
J	449.3	449.3	449.3
K	451.6	451.6	451.6
M	263.5	263.5	263.5
N	263.5	263.5	263.5
O	219.2	219.2	219.2
P	215.9	215.9	215.9
Q	131.8	131.8	131.8
R	2590.8	2590.8	2590.8
S	302.4	302.4	302.4
T	3195.7	3195.7	3195.7
U	377.8	377.8	377.8
V	3371.1	3371.1	3371.1
X	920.8	920.8	920.8
AA	902.5	956.5	956.5
BB	1270.0	1270.0	1270.0

HIGH EFFICIENCY (HE)	
0096HE	0127HE
890.6	884.2
1832.8	1970.9
—	—
1930.4	1930.4
3641.7	3688.6
381.0	381.0
762.0	762.0
141.3	141.3
407.2	407.2
219.1	219.1
1041.4	1041.4
736.6	736.6
449.3	449.3
451.6	451.6
263.5	263.5
263.5	263.5
219.2	219.2
215.9	215.9
131.8	131.8
2590.8	2590.8
302.4	302.4
3195.7	3195.7
376.2	423.1
3371.1	3371.1
920.8	920.8
956.5	888.2
1270.0	1270.0

H\* - for 200/230 volt units, which require a larger electrical enclosure

H\*\* - for multiple point circuit breaker units, 200/230 volt, which require a larger electrical enclosure

# Unit Dimensions - SI - Five & Six Compressor (Cont'd)

**NOTES:**

1. Recommended service clearances  
 Rear to wall: 20" (508mm)  
 Front to wall: 36" (915mm)  
 Top: 43" (1092mm)  
 Tube cleaning and removal: 132" (3353mm)  
 either end
2. Relief valve connection sizes  
 Low side (suction line): 1/2" flare  
 High side (condenser): 5/8" NPTI

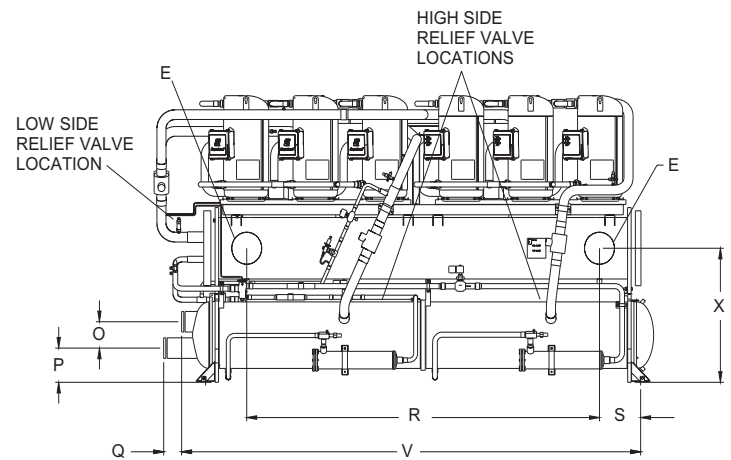
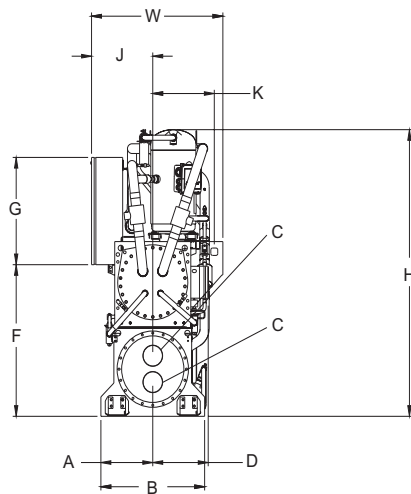
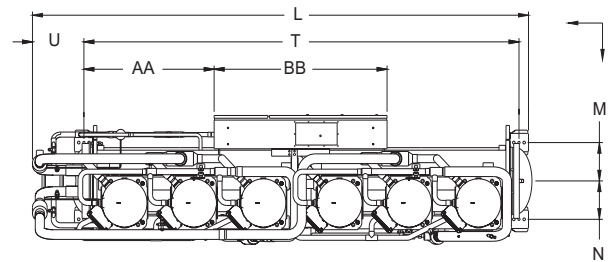

LD18411

# Single Point Electrical Data

## STANDARD EFFICIENCY WITHOUT OPTIONAL EXTERNAL COMPRESSOR OVERLOADS

MODEL YCWL	VOLT	HZ	MINIMUM CIRCUIT AMPS (MCA)	MIN N/F DISC SW	MIN DUAL ELEM FUSE & MIN CB	MAX DUAL ELEM FUSE & MAX CB	LUGS PER PHASE	
							TERMINAL BLOCK LUG SIZE (STD)	
							QTY/ ∅	LUG INFO
0056SE	200	60	206	250	250	250	1	# 10 - 300 KCM
	230	60	206	250	250	250	1	# 10 - 300 KCM
	380	60	117	150	125	125	1	#10 - 3/0AWG
	460	60	103	150	110	110	1	# 12 - 1 AWG
	575	60	74	100	90	100	1	# 12 - 1 AWG
0064SE	200	60	237	400	300	300	1	# 4 - 500 KCM
	230	60	237	400	300	300	1	# 4 - 500 KCM
	380	60	153	200	175	175	1	# 10 - 300 KCM
	460	60	114	150	125	125	1	# 10 - 300 KCM
	575	60	101	150	110	110	1	# 10 - 300 KCM
0074SE	200	60	278	400	300	350	1	# 4 - 500 KCM
	230	60	278	400	300	350	1	# 4 - 500 KCM
	380	60	158	200	175	175	1	# 10 - 300 KCM
	460	60	122	150	150	150	1	# 10 - 300 KCM
	575	60	103	150	110	125	1	# 10 - 300 KCM
0084SE	200	60	314	400	350	350	1	# 4 - 500 KCM
	230	60	314	400	350	350	1	# 4 - 500 KCM
	380	60	162	200	175	200	1	# 10 - 300 KCM
	460	60	129	150	150	150	1	# 10 - 300 KCM
	575	60	105	150	125	125	1	# 10 - 300 KCM
0094SE	200	60	348	400	400	400	2	# 10 - 300 KCM
	230	60	348	400	400	400	2	# 10 - 300 KCM
	380	60	199	250	225	250	1	# 10 - 300 KCM
	460	60	157	200	175	200	1	# 10 - 300 KCM
	575	60	121	150	150	150	1	# 10 - 300 KCM
0104SE	200	60	379	600	450	450	2	# 10 - 300 KCM
	230	60	379	600	450	450	2	# 10 - 300 KCM
	380	60	232	400	250	250	1	# 4 - 500 KCM
	460	60	182	200	200	225	1	# 4 - 500 KCM
	575	60	136	150	150	150	1	# 4 - 500 KCM
0118SE	200	60	381	600	500	500	2	# 10 - 300 KCM
	230	60	381	600	500	500	2	# 10 - 300 KCM
	380	60	230	400	300	300	1	# 4 - 500 KCM
	460	60	190	250	225	250	1	# 4 - 500 KCM
	575	60	152	200	200	200	1	# 4 - 500 KCM
0132SE	200	60	418	600	500	500	2	# 4 - 500 KCM
	230	60	418	600	500	500	2	# 4 - 500 KCM
	380	60	253	400	350	350	1	# 4 - 500 KCM
	460	60	209	400	250	250	1	# 4 - 500 KCM
	575	60	167	250	225	250	1	# 4 - 500 KCM
0157SE	200	60	453	600	600	600	2	# 4 - 500 KCM
	230	60	453	600	600	600	2	# 4 - 500 KCM
	380	60	275	400	350	350	2	# 4 - 500 KCM
	460	60	227	400	250	250	1	# 4 - 500 KCM
	575	60	181	250	225	250	1	# 4 - 500 KCM
0177SE	460	60	280	400	300	300	1	# 4 - 500 KCM
	575	60	224	250	225	225	1	# 4 - 500 KCM
0198SE	460	60	308	400	350	350	1	# 4 - 500 KCM
	575	60	246	400	300	300	1	# 4 - 500 KCM



## Single Point Electrical Data (Cont'd)

### STANDARD EFFICIENCY WITHOUT OPTIONAL EXTERNAL COMPRESSOR OVERLOADS

MODEL YCWL	SYSTEM # 1						SYSTEM # 2					
	COMPR 1		COMPR 2		COMPR 3		COMPR 1		COMPR 2		COMPR 3	
	RLA	LRA	RLA	LRA	RLA	LRA	RLA	LRA	RLA	LRA	RLA	LRA
0056SE	48.5	249	48.5	249			48.5	249	51.3	249		
	48.5	295	48.5	295			48.5	295	51.3	295		
	27.6	159	27.6	159			27.6	159	26.9	159		
	24.4	145	24.4	145			24.4	145	23.1	145		
	17.4	109	17.4	109			17.4	109	19.9	109		
0064SE	55.8	425	55.8	425			55.8	425	55.8	425		
	55.8	425	55.8	425			55.8	425	55.8	425		
	36.0	239	36.0	239			36.0	239	36.0	239		
	26.9	187	26.9	187			26.9	187	26.9	187		
	23.7	148	23.7	148			23.7	148	23.7	148		
0074SE	73.9	505	73.9	505			55.8	425	55.8	425		
	73.9	505	73.9	505			55.8	425	55.8	425		
	38.2	290	38.2	290			36.0	239	36.0	239		
	30.4	225	30.4	225			26.9	187	26.9	187		
	24.6	180	24.6	180			23.7	148	23.7	148		
0084SE	73.9	505	73.9	505			73.9	505	73.9	505		
	73.9	505	73.9	505			73.9	505	73.9	505		
	38.2	290	38.2	290			38.2	290	38.2	290		
	30.4	225	30.4	225			30.4	225	30.4	225		
	24.6	180	24.6	180			24.6	180	24.6	180		
0094SE	89.1	500	89.1	500			73.9	505	73.9	505		
	89.1	500	89.1	500			73.9	505	73.9	505		
	54.5	305	54.5	305			38.2	290	38.2	290		
	42.9	250	42.9	250			30.4	225	30.4	225		
	32.1	198	32.1	198			24.6	180	24.6	180		
0104SE	89.1	500	89.1	500			89.1	500	89.1	500		
	89.1	500	89.1	500			89.1	500	89.1	500		
	54.5	305	54.5	305			54.5	305	54.5	305		
	42.9	250	42.9	250			42.9	250	42.9	250		
	32.1	198	32.1	198			32.1	198	32.1	198		
0118SE	98.4	432	98.4	432			79.4	378	79.4	378		
	98.4	477	98.4	477			79.4	418	79.4	418		
	59.5	299	59.5	299			48.1	252	48.1	252		
	49.2	241	49.2	241			39.7	212	39.7	212		
	39.3	194	39.3	194			31.8	168	31.8	138		
0132SE	98.4	432	98.4	432			98.4	432	98.4	432		
	98.4	477	98.4	477			98.4	477	98.4	477		
	59.5	299	59.5	299			59.5	299	59.5	299		
	49.2	241	49.2	241			49.2	241	49.2	241		
	39.3	194	39.3	194			39.3	194	39.3	194		
0157SE	106.7	527	106.7	527			106.7	527	106.7	527		
	106.7	582	106.7	582			106.7	582	106.7	582		
	64.6	355	64.6	355			64.6	355	64.6	355		
	53.4	280	53.4	280			53.4	280	53.4	280		
	42.7	225	42.7	225			42.7	225	42.7	225		
0177SE	49.2	242	49.2	242	49.2	242	49.2	242	49.2	242		
	39.3	194	39.3	194	39.3	194	39.3	194	39.3	194		
0198SE	49.2	242	49.2	242	49.2	242	49.2	242	49.2	242	49.2	242
	39.3	194	39.3	194	39.3	194	39.3	194	39.3	194	39.3	194

## Single Point Electrical Data (Cont'd)

### HIGH EFFICIENCY WITHOUT OPTIONAL EXTERNAL COMPRESSOR OVERLOADS

MODEL YCWL	VOLT	HZ	MINIMUM CIRCUIT AMPS (MCA)	MIN N/F DISC SW	MIN DUAL ELEM FUSE & MIN CB	MAX DUAL ELEM FUSE & MAX CB	TERMINAL BLOCK LUG SIZE (STD)	
							QTY/ ∅	LUG INFO
0064HE	200	60	245	400	300	300	1	# 4 - 500 KCM
	230	60	245	400	300	300	1	# 4 - 500 KCM
	380	60	131	200	175	175	1	# 10 - 300 KCM
	460	60	114	150	125	125	1	# 10 - 300 KCM
	575	60	91	150	110	110	1	# 10 - 300 KCM
0074HE	200	60	270	400	300	350	1	# 4 - 500 KCM
	230	60	270	400	300	350	1	# 4 - 500 KCM
	380	60	155	200	175	175	1	# 10 - 300 KCM
	460	60	131	150	150	150	1	# 10 - 300 KCM
	575	60	105	150	110	125	1	# 10 - 300 KCM
0084HE	200	60	292	400	350	350	1	# 4 - 500 KCM
	230	60	292	400	350	350	1	# 4 - 500 KCM
	380	60	177	200	175	200	1	# 10 - 300 KCM
	460	60	146	150	150	150	1	# 10 - 300 KCM
	575	60	117	150	125	125	1	# 10 - 300 KCM
0094HE	200	60	316	400	400	400	2	# 10 - 300 KCM
	230	60	316	400	400	400	2	# 10 - 300 KCM
	380	60	191	250	225	250	1	# 10 - 300 KCM
	460	60	158	200	175	200	1	# 10 - 300 KCM
	575	60	126	150	150	150	1	# 10 - 300 KCM
0096HE	200	60	360	400	400	400	2	#10 - 300 KCM
	230	60	360	400	400	400	2	#10 - 300 KCM
	380	60	193	250	250	250	1	# 4 - 500 KCM
	460	60	168	200	175	175	1	# 4 - 500 KCM
	575	60	134	200	175	175	1	# 4 - 500 KCM
0118HE	200	60	381	600	500	500	2	#10 - 300 KCM
	230	60	381	600	500	500	2	#10 - 300 KCM
	380	60	230	400	300	300	1	# 4 - 500 KCM
	460	60	190	250	225	250	1	# 4 - 500 KCM
	575	60	152	200	200	200	1	# 4 - 500 KCM
0127HE	208	60	428	600	500	500	2	# 4 - 500 KCM
	230	60	428	600	500	500	2	# 4 - 500 KCM
	380	60	259	400	300	300	2	#10 - 300 KCM
	460	60	214	250	250	250	1	# 4 - 500 KCM
	575	60	171	250	225	225	1	#10 - 300 KCM
0157HE	208	60	453	600	600	600	2	# 4 - 500 KCM
	230	60	453	600	600	600	2	# 4 - 500 KCM
	380	60	275	400	350	350	2	#10 - 300 KCM
	460	60	227	400	250	250	1	# 4 - 500 KCM
	575	60	181	250	225	250	1	# 4 - 500 KCM

## Single Point Electrical Data (Cont'd)

### HIGH EFFICIENCY WITHOUT OPTIONAL EXTERNAL COMPRESSOR OVERLOADS

MODEL YCWL	SYSTEM # 1						SYSTEM # 2					
	COMPR 1		COMPR 2		COMPR 3		COMPR 1		COMPR 2		COMPR 3	
	RLA	LRA	RLA	LRA	RLA	LRA	RLA	LRA	RLA	LRA	RLA	LRA
0064HE	57.7	284	57.7	284			57.7	284	57.7	284		
	57.7	330	57.7	330			57.7	330	57.7	330		
	30.9	192	30.9	192			30.9	192	30.9	192		
	26.9	180	26.9	180			26.9	180	26.9	180		
	21.5	132	21.5	132			21.5	132	21.5	132		
0074HE	68.8	324	68.8	324			57.7	324	57.7	324		
	68.8	359	68.8	359			57.7	359	57.7	359		
	41.6	253	41.6	253			30.9	253	30.9	253		
	34.4	213	34.4	213			26.9	213	26.9	213		
	27.5	162	27.5	162			21.5	162	21.5	162		
0084HE	68.8	324	68.8	324			68.8	324	68.8	324		
	68.8	359	68.8	359			68.8	359	68.8	359		
	41.6	253	41.6	253			41.6	253	41.6	253		
	34.4	213	34.4	213			34.4	213	34.4	213		
	27.5	162	27.5	162			27.5	162	27.5	162		
0094HE	79.4	378	79.4	378			68.8	324	68.8	324		
	79.4	418	79.4	418			68.8	359	68.8	359		
	48.1	252	48.1	252			41.6	253	41.6	253		
	39.7	212	39.7	212			34.4	213	34.4	213		
	31.8	168	31.8	168			27.5	162	27.5	162		
0096HE	57.7	284	57.7	284	57.7	284	57.7	284	57.7	284	57.7	284
	57.7	330	57.7	330	57.7	330	57.7	330	57.7	330	57.7	330
	30.9	192	30.9	192	30.9	192	30.9	192	30.9	192	30.9	192
	26.9	180	26.9	180	26.9	180	26.9	180	26.9	180	26.9	180
	21.5	132	21.5	132	21.5	132	21.5	132	21.5	132	21.5	132
0118HE	98.4	432	98.4	432			79.4	378	79.4	378		
	98.4	477	98.4	477			79.4	418	79.4	418		
	59.5	299	59.5	299			48.1	252	48.1	252		
	49.2	241	49.2	241			39.7	212	39.7	212		
	39.3	194	39.3	194			31.8	168	31.8	138		
0127HE	68.8	324	68.8	324	68.8	324	98.4	432	98.4	432		
	68.8	359	68.8	359	68.8	359	98.4	477	98.4	477		
	41.6	253	41.6	253	41.6	253	59.5	299	59.5	299		
	34.4	213	34.4	213	34.4	213	49.2	241	49.2	241		
	27.5	162	27.5	162	27.5	162	39.3	194	39.3	194		
0157HE	106.7	527	106.7	527			106.7	527	106.7	527		
	106.7	582	106.7	582			106.7	582	106.7	582		
	64.6	355	64.6	355			64.6	355	64.6	355		
	53.4	280	53.4	280			53.4	280	53.4	280		
	42.7	225	42.7	225			42.7	225	42.7	225		

# Single Point Electrical Data (Cont'd)

## STANDARD EFFICIENCY WITH OPTIONAL EXTERNAL COMPRESSOR OVERLOADS

MODEL YCWL	VOLT	HZ	MINIMUM CIRCUIT AMPS (MCA) *	MIN N/F DISC SW	MIN DUAL ELEM FUSE & MIN CB	MAX DUAL ELEM FUSE & MAX CB	LUGS PER PHASE			
							DISCONNECT SWITCH LUG SIZE (OPT)		CIRCUIT BREAKER LUG SIZE (OPT)	
							QTY/ ∅	LUG INFO	QTY/ ∅	LUG INFO
0056SE	200	60	139	200	175	175	1	# 6 - 350 KCM	1	# 4 - 300 KCM
	230	60	121	200	175	175	1	# 6 - 350 KCM	1	# 4 - 300 KCM
	380	60	73	100	90	100	1	# 14 - 1/0 AWG	1	# 14 - 1/0 AWG
	460	60	60	100	80	80	1	# 14 - 1/0 AWG	1	# 14 - 1/0 AWG
	575	60	48	100	70	70	1	# 14 - 1/0 AWG	1	# 14 - 1/0 AWG
0064SE	200	60	179	200	200	200	1	# 6 - 350 KCM	1	# 4 - 300 KCM
	230	60	179	200	200	200	1	# 6 - 350 KCM	1	# 4 - 300 KCM
	380	60	109	150	125	125	1	# 2 - 4/0 AWG	1	# 2 - 4/0 AWG
	460	60	91	100	100	110	1	# 14 - 1/0 AWG	1	# 14 - 1/0 AWG
	575	60	74	100	80	90	1	# 14 - 1/0 AWG	1	# 14 - 1/0 AWG
0074SE	200	60	195	250	225	225	1	# 6 - 350 KCM	1	# 4 - 300 KCM
	230	60	195	250	225	225	1	# 6 - 350 KCM	1	# 4 - 300 KCM
	380	60	115	150	125	125	1	# 2 - 4/0 AWG	1	# 2 - 4/0 AWG
	460	60	95	150	110	110	1	# 2 - 4/0 AWG	1	# 2 - 4/0 AWG
	575	60	77	100	90	90	1	# 14 - 1/0 AWG	1	# 14 - 1/0 AWG
0084SE	200	60	209	250	225	250	1	# 6 - 350 KCM	1	# 6 - 350 KCM
	230	60	209	250	225	250	1	# 6 - 350 KCM	1	# 6 - 350 KCM
	380	60	120	150	150	150	1	# 2 - 4/0 AWG	1	# 2 - 4/0 AWG
	460	60	99	150	110	110	1	# 2 - 4/0 AWG	1	# 14 - 1/0 AWG
	575	60	80	100	90	90	1	# 14 - 1/0 AWG	1	# 14 - 1/0 AWG
0094SE	200	60	228	250	250	250	1	# 6 - 350 KCM	1	# 6 - 350 KCM
	230	60	228	250	250	250	1	# 6 - 350 KCM	1	# 6 - 350 KCM
	380	60	132	150	150	150	1	# 2 - 4/0 AWG	1	# 2 - 4/0 AWG
	460	60	109	150	125	125	1	# 2 - 4/0 AWG	1	# 2 - 4/0 AWG
	575	60	87	100	100	100	1	# 14 - 1/0 AWG	1	# 14 - 1/0 AWG
0104SE	200	60	245	400	300	300	1	# 250 - 500 KCM	1	# 250 - 500 KCM
	230	60	245	400	300	300	1	# 250 - 500 KCM	1	# 250 - 500 KCM
	380	60	141	200	150	150	1	# 6 - 350 KCM	1	# 4 - 300 KCM
	460	60	117	150	125	125	1	# 2 - 4/0 AWG	1	# 2 - 4/0 AWG
	575	60	94	150	100	110	1	# 14 - 1/0 AWG	1	# 14 - 1/0 AWG
0118SE	200	60	303	400	350	350	1	# 250 - 500 KCM	1	# 250 - 500 KCM
	230	60	260	400	350	350	1	# 250 - 500 KCM	1	# 250 - 500 KCM
	380	60	157	200	200	200	1	# 6 - 350 KCM	1	# 4 - 300 KCM
	460	60	130	150	150	175	1	# 6 - 350 KCM	1	# 4 - 300 KCM
	575	60	104	150	125	125	1	# 2 - 4/0 AWG	1	# 2 - 4/0 AWG
0132SE	200	60	333	400	400	400	1	# 250 - 500 KCM	1	# 250 - 500 KCM
	230	60	290	400	400	400	1	# 250 - 500 KCM	1	# 250 - 500 KCM
	380	60	175	250	225	225	1	# 6 - 350 KCM	1	# 4 - 300 KCM
	460	60	145	200	175	175	1	# 6 - 350 KCM	1	# 4 - 300 KCM
	575	60	116	150	150	150	1	# 2 - 4/0 AWG	1	# 2 - 4/0 AWG
0157SE	200	60	387	600	450	450	2	# 250 - 500 KCM	2	# 250 - 500 KCM
	230	60	337	400	400	400	1	# 250 - 500 KCM	1	# 250 - 500 KCM
	380	60	204	250	225	250	1	# 6 - 350 KCM	1	# 6 - 350 KCM
	460	60	168	200	200	200	1	# 6 - 350 KCM	1	# 6 - 350 KCM
	575	60	135	150	150	150	1	# 4 - 300 KCM	1	# 2 - 4/0 AWG
0177SE	200	60	412	600	450	450	2	# 250 - 500 KCM	2	# 250 - 500 KCM
	230	60	358	400	400	400	2	# 250 - 500 KCM	2	# 250 - 500 KCM
	380	60	217	250	225	250	1	# 250 - 500 KCM	1	# 6 - 350 KCM
	460	60	179	200	200	200	1	# 6 - 350 KCM	1	# 4 - 300 KCM
	575	60	143	200	150	150	1	# 6 - 350 KCM	1	# 2 - 4/0 AWG
0198SE	200	60	490	600	600	600	2	# 250 - 500 KCM	2	# 250 - 500 KCM
	230	60	426	600	450	450	2	# 250 - 500 KCM	2	# 250 - 500 KCM
	380	60	258	400	300	300	1	# 250 - 500 KCM	1	# 250 - 500 KCM
	460	60	213	250	225	225	1	# 6 - 350 KCM	1	# 4 - 300 KCM
	575	60	171	200	175	175	1	# 6 - 350 KCM	1	# 4 - 300 KCM

**Single Point Electrical Data (Cont'd)****STANDARD EFFICIENCY WITH OPTIONAL EXTERNAL COMPRESSOR OVERLOADS**

MODEL YCWL	SYSTEM # 1						SYSTEM # 2					
	COMPR 1		COMPR 2		COMPR 3		COMPR 1		COMPR 2		COMPR 3	
	RLA	LRA	RLA	LRA	RLA	LRA	RLA	LRA	RLA	LRA	RLA	LRA
<b>0056SE</b>	32.7	249	32.7	249			32.7	249	32.7	249		
	28.4	295	28.4	295			28.4	295	28.4	295		
	17.2	159	17.2	159			17.2	159	17.2	159		
	14.2	145	14.2	145			14.2	145	14.2	145		
	11.4	109	11.4	109			11.4	109	11.4	109		
<b>0064SE</b>	42.2	425	42.2	425			42.2	425	42.2	425		
	42.2	425	42.2	425			42.2	425	42.2	425		
	25.7	239	25.7	239			25.7	239	25.7	239		
	21.3	187	21.3	187			21.3	187	21.3	187		
	17.4	148	17.4	148			17.4	148	17.4	148		
<b>0074SE</b>	49.1	505	49.1	505			42.2	425	42.2	425		
	49.1	505	49.1	505			42.2	425	42.2	425		
	28.3	290	28.3	290			25.7	239	25.7	239		
	23.4	225	23.4	225			21.3	187	21.3	187		
	18.7	180	18.7	180			17.4	148	17.4	148		
<b>0084SE</b>	49.1	505	49.1	505			49.1	505	49.1	505		
	49.1	505	49.1	505			49.1	505	49.1	505		
	28.3	290	28.3	290			28.3	290	28.3	290		
	23.4	225	23.4	225			23.4	225	23.4	225		
	18.7	180	18.7	180			18.7	180	18.7	180		
<b>0094SE</b>	57.8	500	57.8	500			49.1	505	49.1	505		
	57.8	500	57.8	500			49.1	505	49.1	505		
	33.3	305	33.3	305			28.3	290	28.3	290		
	27.5	250	27.5	250			23.4	225	23.4	225		
	22.0	198	22.0	198			18.7	180	18.7	180		
<b>0104SE</b>	57.8	500	57.8	500			57.8	500	57.8	500		
	57.8	500	57.8	500			57.8	500	57.8	500		
	33.3	305	33.3	305			33.3	305	33.3	305		
	27.5	250	27.5	250			27.5	250	27.5	250		
	22.0	198	22.0	198			22.0	198	22.0	198		
<b>0118SE</b>	78.5	432	78.5	432			61.1	378	61.1	378		
	68.2	477	68.2	477			53.1	418	53.1	418		
	41.3	299	41.3	299			32.2	252	32.2	252		
	34.1	241	34.1	241			26.6	212	26.6	212		
	27.3	194	27.3	194			21.1	168	21.2	138		
<b>0132SE</b>	78.5	432	78.5	432			78.5	432	78.5	432		
	68.2	477	68.2	477			68.2	477	68.2	477		
	41.3	299	41.3	299			41.3	299	41.3	299		
	34.1	241	34.1	241			34.1	241	34.1	241		
	27.3	194	27.3	194			27.3	194	27.3	194		
<b>0157SE</b>	91.2	527	91.2	527			91.2	527	91.2	527		
	79.3	582	79.3	582			79.3	582	79.3	582		
	48.0	355	48.0	355			48.0	355	48.0	355		
	39.6	280	39.6	280			39.6	280	39.6	280		
	31.7	225	31.7	225			31.7	225	31.7	225		
<b>0177SE</b>	78.5	432	78.5	432	78.5	432	78.5	432	78.5	432		
	68.2	477	68.2	477	68.2	477	68.2	477	68.2	477		
	41.3	299	41.3	299	41.3	299	41.3	299	41.3	299		
	34.1	242	34.1	242	34.1	242	34.1	242	34.1	242		
	27.3	194	27.3	194	27.3	194	27.3	194	27.3	194		
<b>0198SE</b>	78.5	432	78.5	432	78.5	432	78.5	432	78.5	432	78.5	432
	68.2	477	68.2	477	68.2	477	68.2	477	68.2	477	68.2	477
	41.3	299	41.3	299	41.3	299	41.3	299	41.3	299	41.3	299
	34.1	242	34.1	242	34.1	242	34.1	242	34.1	242	34.1	242
	27.3	194	27.3	194	27.3	194	27.3	194	27.3	194	27.3	194

# Single Point Electrical Data (Cont'd)

## HIGH EFFICIENCY WITH OPTIONAL EXTERNAL COMPRESSOR OVERLOADS

MODEL YCWL	VOLT	HZ	MINIMUM CIRCUIT AMPS (MCA)*	MIN N/F DISC SW	MIN DUAL ELEM FUSE & MIN CB	MAX DUAL ELEM FUSE & MAX CB	LUGS PER PHASE			
							DISCONNECT SWITCH LUG SIZE (OPT)		CIRCUIT BREAKER LUG SIZE (OPT)	
							QTY/ ∅	LUG INFO	QTY/ ∅	LUG INFO
0064HE	200	60	170	200	200	200	1	# 6 - 350 KCM	1	# 4 - 300 KCM
	230	60	148	200	200	200	1	# 6 - 350 KCM	1	# 4 - 300 KCM
	380	60	90	150	125	125	1	# 2 - 4/0 AWG	1	# 2 - 4/0 AWG
	460	60	74	100	100	110	1	# 14 - 1/0 AWG	1	# 14 - 1/0 AWG
	575	60	59	70	70	70	1	# 14 - 1/0 AWG	1	# 14 - 1/0 AWG
0074HE	200	60	195	250	225	225	1	# 6 - 350 KCM	1	# 4 - 300 KCM
	230	60	170	250	225	225	1	# 6 - 350 KCM	1	# 4 - 300 KCM
	380	60	103	150	125	125	1	# 2 - 4/0 AWG	1	# 2 - 4/0 AWG
	460	60	85	150	110	110	1	# 2 - 4/0 AWG	1	# 2 - 4/0 AWG
	575	60	69	100	90	90	1	# 14 - 1/0 AWG	1	# 14 - 1/0 AWG
0084HE	200	60	217	250	225	250	1	# 6 - 350 KCM	1	# 6 - 350 KCM
	230	60	189	250	225	250	1	# 6 - 350 KCM	1	# 6 - 350 KCM
	380	60	114	150	150	150	1	# 2 - 4/0 AWG	1	# 2 - 4/0 AWG
	460	60	94	150	110	110	1	# 2 - 4/0 AWG	1	# 14 - 1/0 AWG
	575	60	76	100	90	90	1	# 14 - 1/0 AWG	1	# 14 - 1/0 AWG
0094HE	200	60	240	250	250	250	1	# 6 - 350 KCM	1	# 6 - 350 KCM
	230	60	208	250	250	250	1	# 6 - 350 KCM	1	# 6 - 350 KCM
	380	60	126	150	150	150	1	# 2 - 4/0 AWG	1	# 2 - 4/0 AWG
	460	60	104	150	125	125	1	# 2 - 4/0 AWG	1	# 2 - 4/0 AWG
	575	60	83	100	100	100	1	# 14 - 1/0 AWG	1	# 14 - 1/0 AWG
0096HE	200	60	251	400	300	300	1	# 250 - 500 KCM	1	# 250 - 500 KCM
	230	60	218	400	300	300	1	# 250 - 500 KCM	1	# 250 - 500 KCM
	380	60	132	200	175	175	1	# 6 - 350 KCM	1	# 4 - 300 KCM
	460	60	109	150	150	150	1	# 6 - 350 KCM	1	# 2 - 4/0 AWG
	575	60	87	150	125	125	1	# 2 - 4/0 AWG	1	# 2 - 4/0 AWG
0118HE	200	60	303	400	350	350	1	# 250 - 500 KCM	1	# 250 - 500 KCM
	230	60	260	400	350	350	1	# 250 - 500 KCM	1	# 250 - 500 KCM
	380	60	157	200	200	200	1	# 6 - 350 KCM	1	# 4 - 300 KCM
	460	60	130	150	150	175	1	# 6 - 350 KCM	1	# 2 - 4/0 AWG
	575	60	104	150	125	125	1	# 2 - 4/0 AWG	1	# 2 - 4/0 AWG
0127HE	200	60	330	400	400	400	1	# 250 - 500 KCM	1	# 250 - 500 KCM
	230	60	287	400	350	400	1	# 250 - 500 KCM	1	# 250 - 500 KCM
	380	60	174	250	200	225	1	# 6 - 350 KCM	1	# 6 - 350 KCM
	460	60	143	200	175	175	1	# 6 - 350 KCM	1	# 6 - 350 KCM
	575	60	115	150	150	150	1	# 4 - 300 KCM	1	# 2 - 4/0 AWG
0157HE	200	60	387	600	450	450	2	# 250 - 500 KCM	2	# 250 - 500 KCM
	230	60	337	400	400	400	1	# 250 - 500 KCM	1	# 250 - 500 KCM
	380	60	204	250	225	250	1	# 6 - 350 KCM	1	# 6 - 350 KCM
	460	60	168	200	200	200	1	# 6 - 350 KCM	1	# 6 - 350 KCM
	575	60	135	150	150	150	1	# 4 - 300 KCM	1	# 2 - 4/0 AWG

## Single Point Electrical Data (Cont'd)

### HIGH EFFICIENCY WITH OPTIONAL EXTERNAL COMPRESSOR OVERLOADS

MODEL YCWL	SYSTEM # 1						SYSTEM # 2					
	COMPR 1		COMPR 2		COMPR 3		COMPR 1		COMPR 2		COMPR 3	
	RLA	LRA	RLA	LRA	RLA	LRA	RLA	LRA	RLA	LRA	RLA	LRA
0064HE	40.1	284	40.1	284			40.1	284	40.1	284		
	34.9	330	34.9	330			34.9	330	34.9	330		
	21.1	192	21.1	192			21.1	192	21.1	192		
	17.4	180	17.4	180			17.4	180	17.4	180		
	13.9	132	13.9	132			13.9	132	13.9	132		
0074HE	51.1	324	51.1	324			40.1	284	40.1	284		
	44.5	359	44.5	359			34.9	330	34.9	330		
	26.9	253	26.9	253			21.1	192	21.1	192		
	22.2	213	22.2	213			17.4	180	17.4	180		
	17.8	162	17.8	162			13.9	132	13.9	132		
0084HE	51.1	324	51.1	324			51.1	324	51.1	324		
	44.5	359	44.5	359			44.5	359	44.5	359		
	26.9	253	26.9	253			26.9	253	26.9	253		
	22.2	213	22.2	213			22.2	213	22.2	213		
	17.8	162	17.8	162			27.5	162	17.8	162		
0094HE	61.1	378	61.1	378			51.1	324	51.1	324		
	53.1	418	53.1	418			44.5	359	44.5	359		
	32.2	252	32.2	252			26.9	253	26.9	253		
	26.6	212	26.6	212			22.2	213	22.2	213		
	21.2	168	21.2	168			27.5	162	17.8	162		
0096HE	40.1	284	40.1	284	40.1	284	40.1	284	40.1	284	40.1	284
	34.9	330	34.9	330	34.9	330	34.9	330	34.9	330	34.9	330
	21.1	192	21.1	192	21.1	192	21.1	192	21.1	192	21.1	192
	17.4	180	17.4	180	17.4	180	17.4	180	17.4	180	17.4	180
	13.9	132	13.9	132	13.9	132	13.9	132	13.9	132	13.9	132
0118HE	78.5	432	78.5	432			61.1	378	61.1	378		
	68.2	477	68.2	477			53.1	418	53.1	418		
	41.3	299	41.3	299			32.2	252	32.2	252		
	34.1	241	34.1	241			26.6	212	26.6	212		
	27.3	194	27.3	194			21.1	168	21.2	138		
0127HE	51.1	324	51.1	324	51.1	324	78.5	432	78.5	432		
	44.5	359	44.5	359	44.5	359	68.2	477	68.2	477		
	26.9	253	26.9	253	26.9	253	41.3	299	41.3	299		
	22.2	213	22.2	213	22.2	213	34.1	241	34.1	241		
	17.8	162	17.8	162	17.8	162	27.3	194	27.3	194		
0157HE	91.2	527	91.2	527			91.2	527	91.2	527		
	79.3	582	79.3	582			79.3	582	79.3	582		
	48.0	355	48.0	355			48.0	355	48.0	355		
	39.6	280	39.6	280			39.6	280	39.6	280		
	31.7	225	31.7	225			31.7	225	31.7	225		

# Dual Point Electrical Data

## STANDARD EFFICIENCY WITH EXTERNAL COMPRESSOR OVERLOADS

MODEL YCWL	VOLT	HZ	SYSTEM 1 WIRING				SYSTEM 2 WIRING			
			MINIMUM CIRCUIT AMPS	MIN N/F DISC SW	MIN DUAL ELEM FUSE & MIN CB	MAX DUAL ELEM FUSE & MAX CB	MINIMUM CIRCUIT AMPS	MIN N/F DISC SW	MIN DUAL ELEM FUSE & MIN CB	MAX DUAL ELEM FUSE & MAX CB
0056SE	208	60	74	100	90	110	74	100	90	110
	230	60	64	100	90	110	64	100	90	110
	380	60	39	60	50	60	39	60	50	60
	460	60	32	60	45	50	32	60	45	50
	575	60	26	60	40	45	26	60	40	45
0064SE	208	60	95	100	110	125	95	100	110	125
	230	60	95	100	110	125	95	100	110	125
	380	60	58	60	70	80	58	60	70	80
	460	60	48	60	60	60	48	60	60	60
	575	60	39	60	45	50	39	60	45	50
0074SE	208	60	111	150	125	150	95	100	110	125
	230	60	111	150	125	150	95	100	110	125
	380	60	64	100	80	90	58	60	70	80
	460	60	53	60	60	70	48	60	60	60
	575	60	42	60	50	60	39	60	45	50
0084SE	208	60	111	150	125	150	111	150	125	150
	230	60	111	150	125	150	111	150	125	150
	380	60	64	100	80	90	64	100	80	90
	460	60	53	60	60	70	53	60	60	70
	575	60	42	60	50	60	42	60	50	60
0094SE	208	60	130	150	150	175	111	150	125	150
	230	60	130	150	150	175	111	150	125	150
	380	60	75	100	90	100	64	100	80	90
	460	60	62	100	70	80	53	60	60	70
	575	60	50	60	60	70	42	60	50	60
0104SE	208	60	130	150	150	175	130	150	150	175
	230	60	130	150	150	175	130	150	150	175
	380	60	75	100	90	100	75	100	90	100
	460	60	62	100	70	80	62	100	70	80
	575	60	50	60	60	70	50	60	60	70
0118SE	208	60	177	200	200	250	137	150	150	175
	230	60	154	200	200	250	120	150	150	175
	380	60	93	150	125	125	73	100	90	100
	460	60	77	100	100	110	60	100	70	80
	575	60	62	100	80	90	49	60	60	70
0132SE	208	60	177	200	200	250	177	200	200	250
	230	60	154	200	200	250	154	200	200	250
	380	60	93	150	125	125	93	150	125	125
	460	60	77	100	100	110	77	100	100	110
	575	60	62	100	80	90	62	100	80	90
0157SE	208	60	205	200	225	225	205	200	225	225
	230	60	178	200	225	225	178	200	225	225
	380	60	108	150	125	125	108	150	125	125
	460	60	89	100	100	110	89	100	100	110
	575	60	71	100	80	90	71	100	80	90
0177SE	208	60	255	400	300	300	177	200	200	250
	230	60	222	250	250	250	154	200	200	250
	380	60	134	150	150	150	93	150	125	125
	460	60	111	150	125	125	77	100	100	110
	575	60	89	100	100	110	62	100	80	90
0198SE	208	60	255	400	300	300	255	400	300	300
	230	60	222	250	250	250	222	250	250	250
	380	60	134	150	150	150	134	150	150	150
	460	60	111	150	125	125	111	150	125	125
	575	60	89	100	100	110	89	100	100	110





## Dual Point Electrical Data (Cont'd)

### HIGH EFFICIENCY WITH EXTERNAL COMPRESSOR OVERLOADS

MODEL YCWL	VOLT	HZ	SYSTEM 1 WIRING				SYSTEM 2 WIRING			
			MINIMUM CIRCUIT AMPS	MIN N/F DISC SW	MIN DUAL ELEM FUSE & MIN CB	MAX DUAL ELEM FUSE & MAX CB	MINIMUM CIRCUIT AMPS	MIN N/F DISC SW	MIN DUAL ELEM FUSE & MIN CB	MAX DUAL ELEM FUSE & MAX CB
0064HE	208	60	91	100	110	125	91	100	110	125
	230	60	79	100	110	125	79	100	110	125
	380	60	48	60	70	80	48	60	70	80
	460	60	40	60	60	60	40	60	60	60
	575	60	32	60	45	50	32	60	45	50
0074HE	208	60	115	150	125	150	91	100	110	125
	230	60	100	150	125	150	79	100	110	125
	380	60	61	100	80	90	48	60	70	80
	460	60	50	60	60	70	40	60	60	60
	575	60	40	60	50	60	32	60	45	50
0084HE	208	60	115	150	125	150	115	150	125	150
	230	60	100	150	125	150	100	150	125	150
	380	60	61	100	80	90	61	100	80	90
	460	60	50	60	60	70	50	60	60	70
	575	60	40	60	50	60	40	60	50	60
0094HE	208	60	137	150	150	175	115	150	125	150
	230	60	120	150	150	175	100	150	125	150
	380	60	73	100	90	100	61	100	80	90
	460	60	60	100	70	80	50	60	60	70
	575	60	49	60	60	70	40	60	50	60
0096HE	208	60	131	150	150	175	131	150	150	175
	230	60	114	150	150	175	114	150	150	175
	380	60	69	100	90	100	69	100	90	100
	460	60	57	100	80	90	57	100	80	90
	575	60	45	100	70	70	45	100	70	70
0118HE	208	60	177	200	200	250	137	150	150	175
	230	60	154	200	200	250	120	150	150	175
	380	60	93	150	125	125	73	100	90	100
	460	60	77	100	100	110	60	100	70	80
	575	60	62	100	80	90	49	60	60	70
0127HE	208	60	166	200	200	200	177	200	200	250
	230	60	145	200	175	200	154	200	200	250
	380	60	88	100	100	110	93	150	125	125
	460	60	73	100	90	90	77	100	100	110
	575	60	58	100	70	70	62	100	80	90
0157HE	208	60	205	200	225	225	205	200	225	225
	230	60	178	200	225	225	178	200	225	225
	380	60	108	150	125	125	108	150	125	125
	460	60	89	100	100	110	89	100	100	110
	575	60	71	100	80	90	71	100	80	90



# Electrical Notes

1. Minimum Circuit Ampacity (MCA) is based on 125% of the rated load amps for the largest motor plus 100% of the rated load amps for all other loads included in the circuit, per N.E.C. Article 43024. If the optional Factory Mounted Control Transformer is provided, add the following MCA values to the electrical tables for the system providing power to the transformer: 17, add 2.5 amps; 28, add 2.3 amps; 40, add 1.5 amps, 46, add 1.3 amps; 58, add 1 amps.
2. MCA for units with optional external compressor overloads is calculated at 54/44 evaporator (water), 85/95 condenser (water) condition per UL1995. If unit is to be operated at higher temperatures, increase Service Wiring and Equipment accordingly.
3. For Leaving Condenser Temperatures above 95°F (with maximum limit of 110°F) use the following formula:

$$RMCA = MCA * (1 + (DLCT - 95)/100 )$$

DLCT is "Design Leaving Condenser Temperature"  
RMCA is "Recommended Minimum Circuit Ampacity"

4. The minimum recommended disconnect switch is based on 115% of the rated load amps for all loads included in the circuit, per N.E.C. Article 440.
5. Minimum fuse size is based upon 150% of the rated load amps for the largest motor plus 100% of the rated load amps for all other loads included in the circuit to avoid nuisance trips at startup due to lock rotor amps. It is not recommended in applications where brown outs, frequent starting and stopping of the unit, and/or operation at ambient temperatures in excess of 95°F (35°C) is anticipated.
6. Maximum fuse size is based upon 225% of the rated load amps for the largest motor plus 100% of the rated load amps for all other loads included in the circuit, per N.E.C. Article 440-22.
7. Circuit breakers must be UL listed and CSA certified and maximum size is based on 225% of the rated load amps for the largest motor plus 100% of the rated load amps for all other loads included in the circuit. Otherwise, an HACR type circuit breakers must be used. Maximum HACR circuit breaker rating is based on 225% of the rated The "INCOMING WIRE RANGE" is the minimum and maximum wire size that can be accommodated by the unit wiring lugs. The (2) preceding the wire range indicates the number of termination points available per phase of the wire range specified. Actual wire size and number of wires per phase must be determined based on the National Electrical Code, using copper connectors only. Field wiring must also comply with local codes.
8. An equipment ground lug(s) is provided for the incoming power. Ground line sizing shall be in accordance with the current NEC Table 250-122.
9. The supplied disconnect is a "Disconnecting Means" as defined in the N.E.C. 100, and is intended for isolating the unit for the available power supply to perform maintenance and troubleshooting. This disconnect is not intended to be a Load Break Device.
10. Field Wiring by others which complies to the National Electrical Code & Local Codes.
11. Voltage Utilization Range

**LEGEND**

- |                  |  |
|------------------|--|
| ACR              | ACROSS THE LINE START                              |
| C.B.             | CIRCUIT BREAKER                                    |
| D.E.             | DUAL ELEMENT FUSE                                  |
| DISC SW          | DISCONNECT SWITCH                                  |
| FACT MOUNT CB    | FACTORY MOUNTED CIRCUIT BREAKER                    |
| FLA              | FULL LOAD AMPS                                     |
| HZ               | HERTZ  |
| MAX              | MAXIMUM  |
| MCA              | MINIMUM CIRCUIT AMPACITY                           |
| MIN              | MINIMUM  |
| MIN NF           | MINIMUM NON FUSED                                  |
| RLA              | RATED LOAD AMPS                                    |
| S.P. WIRE        | SINGLE POINT WIRING                                |
| UNIT MTD SERV SW | UNIT MOUNTED SERVICE (NON-FUSED DISCONNECT SWITCH) |
| LRA              | LOCKED ROTOR AMPS                                  |
| ECWT             | ENTERING CONDENSER WATER TEMPERATURE               |

Rated Voltage	Utilization Range
208/60/3	187 - 229
230/60/3	200 - 254
380/60/3	342 - 402
460/60/3	414 - 508
575/60/3	520 - 635

## Ground Wire Sizing

GROUND LUG SIZING WITH OR WITHOUT OPTIONAL OVERLOADS		
NON FUSED DISCONNECT SWITCH OPTION		
RATING	INCOMING WIRE	GROUND WIRE
150A	# 14 - 1/0 AWG	# 8 - 2 AWG
150A	# 2 - 4/0 AWG	# 8 - 2 AWG
150A	# 4 - 300 KCM	# 8 - 2 AWG
225A	# 4 - 300 KCM	# 6 - 1/0 AWG
250A	# 6 - 350 KCM	# 4 - 3/0 AWG
400A	# 250 - 500 KCM	# 2 - 4/0 AWG
400A	(2) # 3/0 - 250 KCM	(2) # 6 - 1/0 AWG
600A	(2) # 250 - 500 KCM	(2) # 2 - 4/0 AWG
800A	(2) # 250 - 500 KCM	(2) # 2 - 4/0 AWG
800A	(3) # 2/0 - 400 KCM	(3) # 4 - 3/0 AWG
CIRCUIT BREAKER OPTION		
RATING	INCOMING WIRE	GROUND WIRE
60A	# 14 - 1/0 AWG	# 14 - 6 AWG
70A	# 14 - 1/0 AWG	# 14 - 6 AWG
80A	# 14 - 1/0 AWG	# 14 - 6 AWG
90A	# 14 - 1/0 AWG	# 14 - 6 AWG
100A	# 14 - 1/0 AWG	# 8 - 2 AWG
125A	# 14 - 1/0 AWG	# 8 - 2 AWG
125A	# 2 - 4/0 AWG	# 8 - 2 AWG
150A	# 2 - 4/0 AWG	# 8 - 2 AWG
175A	# 4 - 300 KCM	# 6 - 1/0 AWG
200A	# 4 - 300 KCM	# 6 - 1/0 AWG
225A	# 4 - 300 KCM	# 6 - 1/0 AWG
250A	# 6 - 350 KCM	# 4 - 3/0 AWG
400A	# 250 - 500 KCM	# 2 - 4/0 AWG
400A	(2) # 3/0 - 250 KCM	(2) # 6 - 1/0 AWG
600A	(2) # 250 - 500 KCM	(2) # 2 - 4/0 AWG
TERMINAL BLOCK OPTION		
RATING	INCOMING WIRE	GROUND WIRE
130A	# 12 - 1 AWG	# 8 - 2 AWG
165A	# 10 - 3/0 AWG	# 6 - 1/0 AWG
240A	# 10 - 300 KCM	# 4 - 3/0 AWG
320A	# 4 - 500 KCM	# 2 - 4/0 AWG
480A	(2) # 10 - 300 KCM	(2) # 4 - 3/0 AWG

### INSTRUCTIONS:

1. Start in correct power option table (switch, breaker, terminal block)
2. Match engineering guide value for amperage
3. Match engineering guide value for wire range
4. Note corresponding ground wire range

# Typical Control Panel Wiring

## 4 COMPRESSOR UNITS

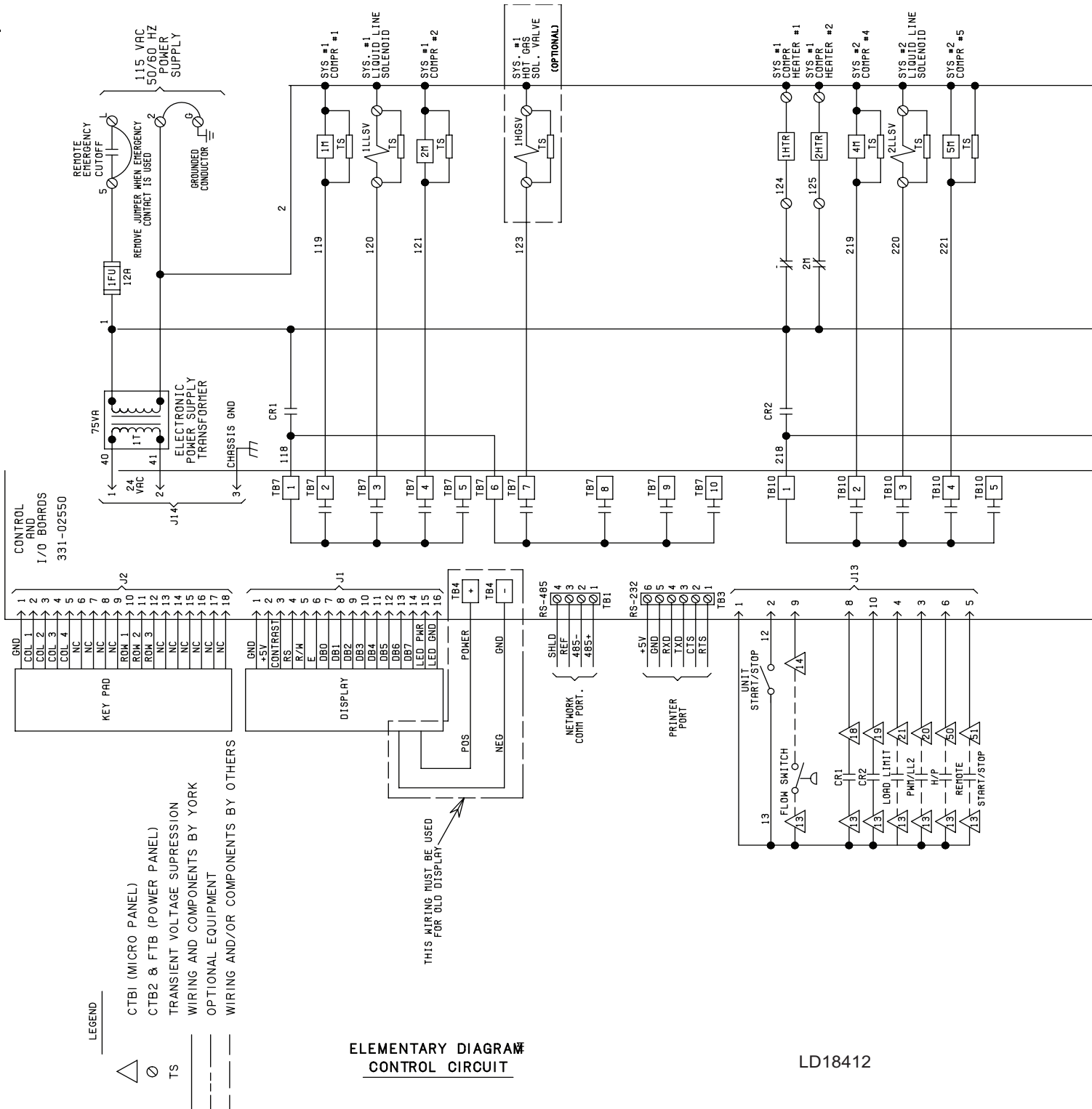

LEGEND



WIRING AND COMPONENTS BY YORK  
 OPTIONAL EQUIPMENT  
 WIRING AND/OR COMPONENTS BY OTHERS

ELEMENTARY DIAGRAM  
 CONTROL CIRCUIT

LD18412

# Typical Control Panel Wiring (Cont'd)

## 4 COMPRESSOR UNITS

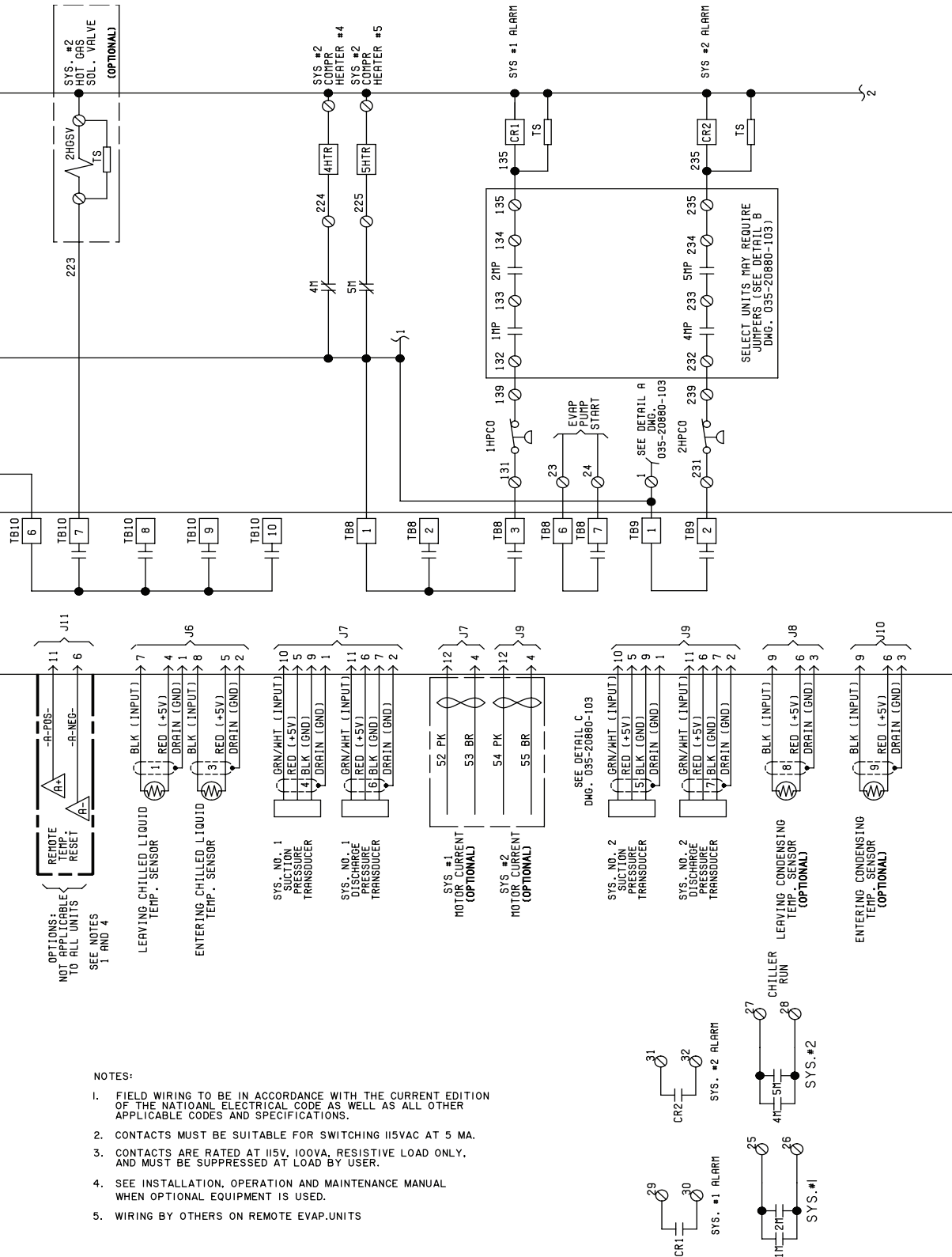

- NOTES:
1. FIELD WIRING TO BE IN ACCORDANCE WITH THE CURRENT EDITION OF THE NATIONAL ELECTRICAL CODE AS WELL AS ALL OTHER APPLICABLE CODES AND SPECIFICATIONS.
  2. CONTACTS MUST BE SUITABLE FOR SWITCHING 115VAC AT 5 MA.
  3. CONTACTS ARE RATED AT 115V, 100VA, RESISTIVE LOAD ONLY, AND MUST BE SUPPRESSED AT LOAD BY USER.
  4. SEE INSTALLATION, OPERATION AND MAINTENANCE MANUAL WHEN OPTIONAL EQUIPMENT IS USED.
  5. WIRING BY OTHERS ON REMOTE EVAP. UNITS

# Typical Control Panel Wiring (Cont'd)

## 5 & 6 COMPRESSOR UNITS

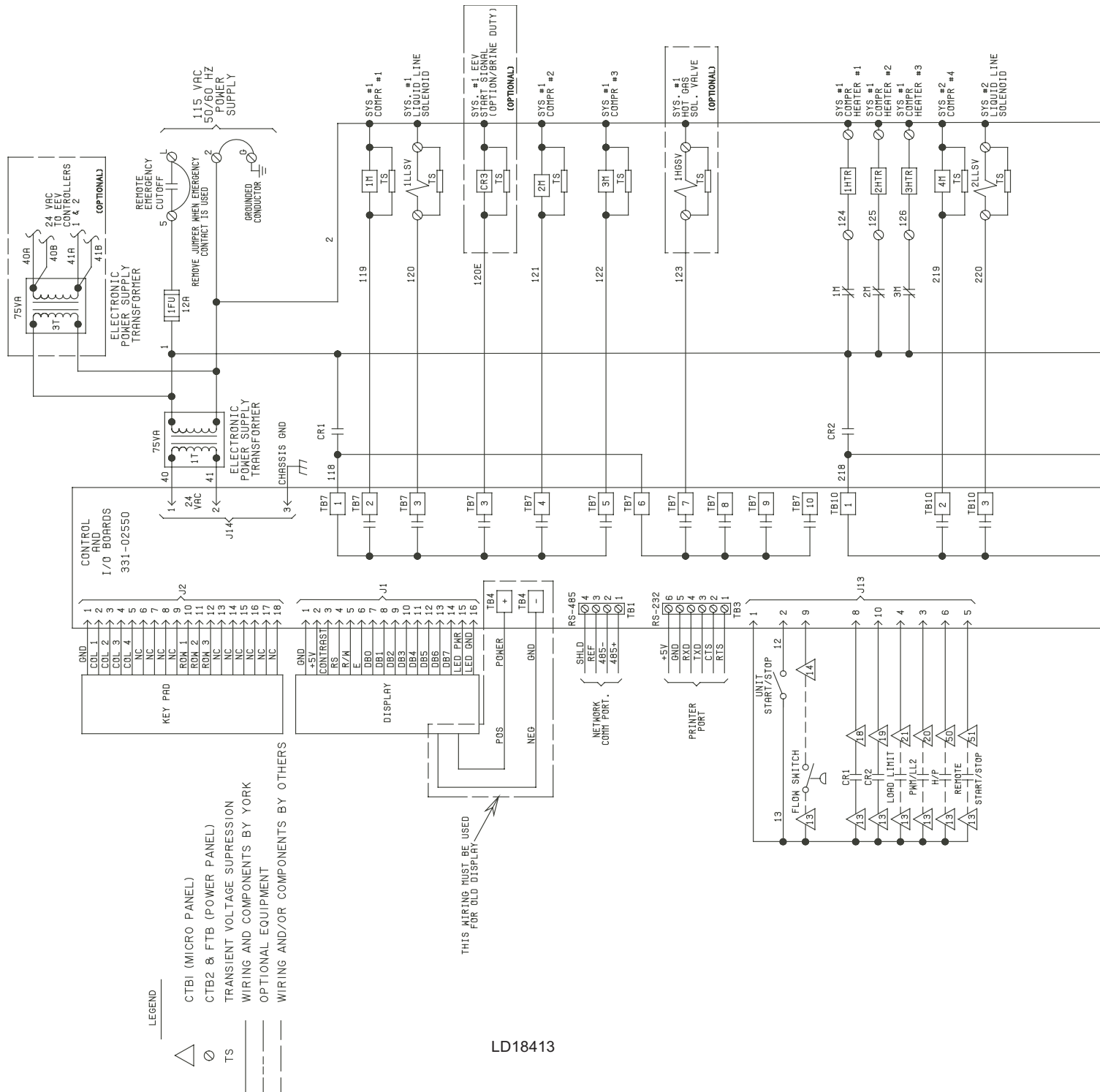



# Typical Control Panel Wiring (Cont'd)

## 5 & 6 COMPRESSOR UNITS

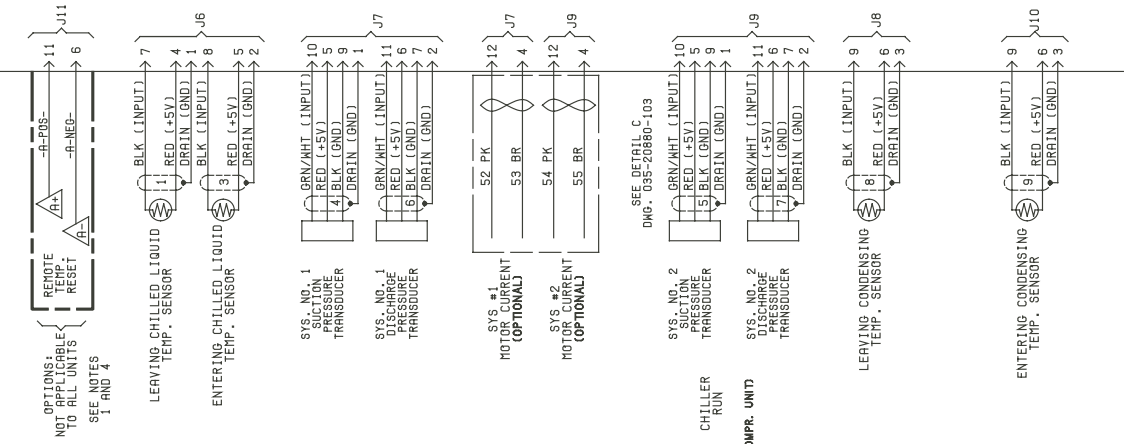
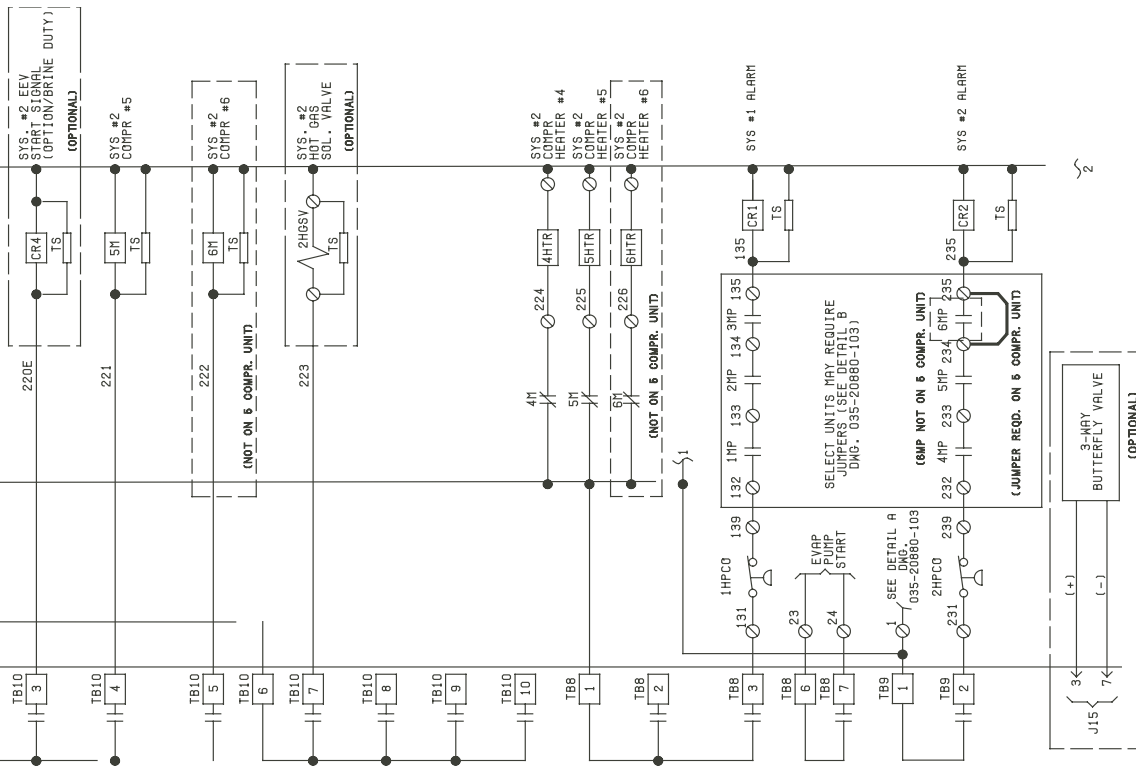

- NOTES:
- FIELD WIRING TO BE IN ACCORDANCE WITH THE CURRENT EDITION OF THE NATIONAL ELECTRICAL CODE AS WELL AS ALL OTHER APPLICABLE CODES AND SPECIFICATIONS.
  - CONTACTS MUST BE SUITABLE FOR SWITCHING 115VAC AT 5 MA.
  - CONTACTS ARE RATED AT 115V, 100VA, RESISTIVE LOAD ONLY, AND MUST BE SUPPRESSED AT LOAD BY USER.
  - SEE INSTALLATION, OPERATION AND MAINTENANCE MANUAL WHEN OPTIONAL EQUIPMENT IS USED.
  - WIRING BY OTHERS TO REMOTE EQUIPMENTS

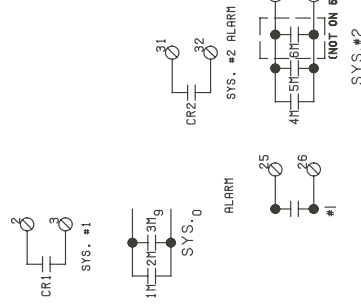

# Customer Wiring Information

STD FIELD PROVIDED  
120-1-60 POWER SUPPLY  
(NOT REQUIRED IF OPTIONAL  
CONTROL TRANSFORMER  
FITTED)

FIELD PROVIDED UNIT  
POWER SUPPLY

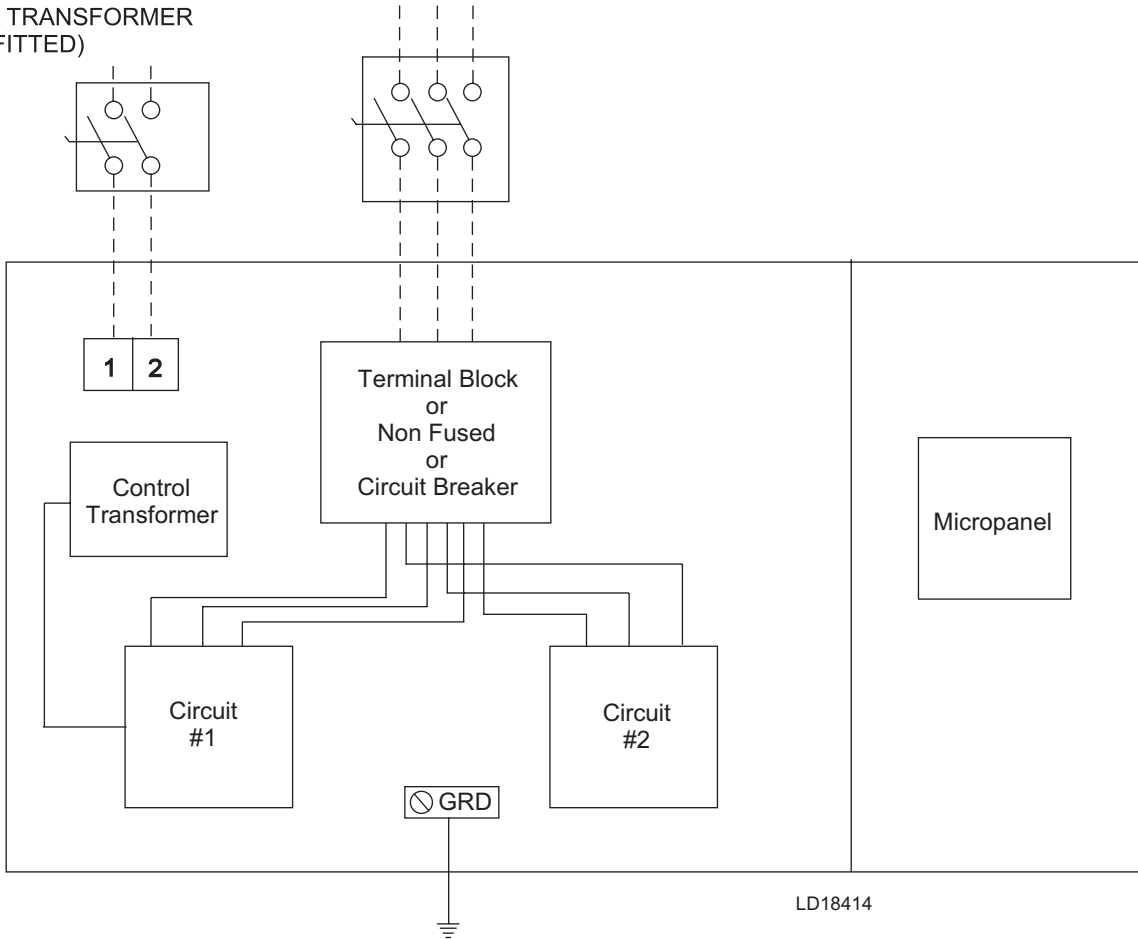

FIGURE 1 - SINGLE POINT POWER SUPPLY CONNECTION – STANDARD UNIT

# Customer Wiring Information (Cont'd)

STD FIELD PROVIDED  
120-1-60 POWER SUPPLY  
(NOT REQUIRED IF OPTIONAL  
CONTROL TRANSFORMER  
FITTED)

FIELD PROVIDED UNIT  
POWER SUPPLY

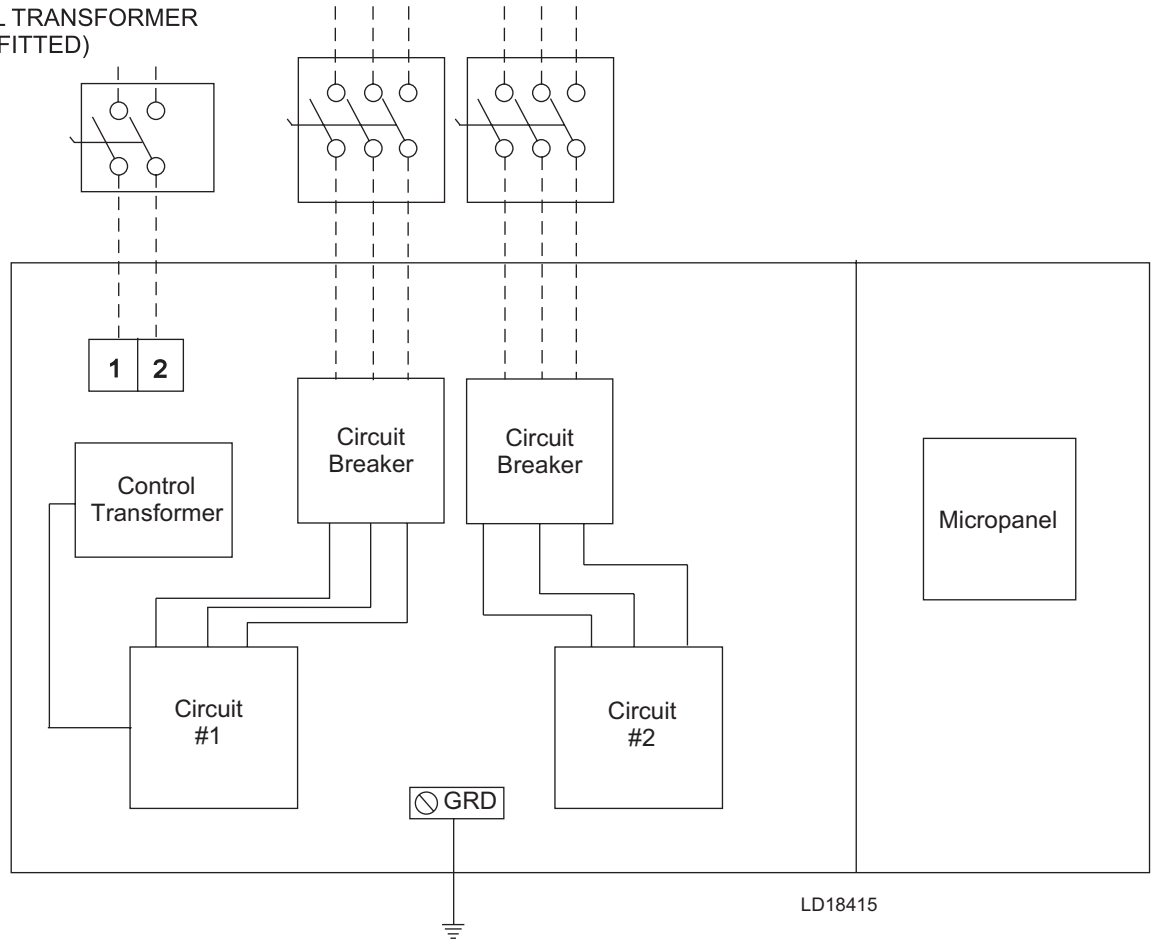

FIGURE 2 - DUAL POINT POWER SUPPLY CONNECTION – OPTIONAL

# Application Data

## UNIT LOCATION

Chillers are designed for indoor installation. Units should be located away from noise-critical areas. Service clearance must be allowed and include space for removing condenser tubes. A doorway or window can sometimes provide space for tube removal. Units should be installed indoors where they are not exposed to rain or water splash. Chillers should be located near a drain. The use of chillers in corrosive, dusty or explosive atmospheres should be avoided unless the unit is properly protected. A unit located in a clean room will run best, require least maintenance, and last longest. Heat or ventilation may be required to maintain the ambient between 40°F and 115°F (4.4°C and 46.1°C).

## UNIT ISOLATION

The chiller foundation must be rigid to reduce vibration transmission to a minimum. All upper story installations should use vibration isolators under the unit base. To maintain isolator efficiency, no mechanical ties should be made to the building. Properly selected flexible connectors and piping isolators are recommended. All the above recommendations will help to reduce vibration transmission and result in a quieter operation.

## FIELD CONNECTED WATER PIPING

Piping must comply in all respects with applicable local plumbing codes and ordinances. In no case should the unit support the weight of connecting piping. Since elbows, tees, and valves increase pressure drop, all piping should be kept as simple as possible. Hand stop valves should be installed where required to facilitate servicing. Piping to the inlet and outlet connections of the evaporator and condenser may include high-pressure rubber hose or piping loops to ensure against water pump transmission of vibration.

Facilities should be provided for measuring temperature and pressure in the evaporator and condenser field water piping. Drain connections should be provided at all low points to permit complete drainage of the evaporator(s), condenser(s), and system piping. This is especially important if the unit is located in an unheated room where freezing could prevail. Water lines subjected to ambient temperatures below freezing may require heater cables or antifreeze (by others).

Water loops should contain provisions for venting. A strainer, preferably 40 mesh, should be installed in the evaporator and condenser inlet lines, and located where it will protect the circulating pump and the heat exchanger tube bundles. It should be determined that the maximum water pressure at the evaporator or condenser does not exceed the maximum design working pressure of the evaporator or condenser.

The water circulating pumps should be located on the inlet side of the heat exchangers. If, however, space does not permit this, the pumps may be located in the outlet water piping. The net positive suction head must be considered when applying pumps.

## ***Application Data (Cont'd)***

### **FIELD WIRING**

All field wiring must comply with the National Electric Code and all applicable local codes. YORK liquid chiller units are factory wired for optimum reliability. Therefore the unit controls must not be modified without expressed written consent by Johnson Controls. The use of a simple switch or timer from a remote point is permitted; but it must be connected to the unit panel at points expressly indicated for that purpose.

### **CONDENSER WATER**

The chiller is engineered for maximum efficiency at both design and part-load operation by taking advantage of the colder cooling tower water temperatures which naturally occur during the winter months. Appreciable power savings are realized from these reduced heads. For stable unit performance, continuous operation with entering condenser water temperature below 65°F (18°C) is not recommended. For operation with entering condenser water temperature below this, it is recommended that some type of condenser water temperature control be used.

### **REFRIGERANT RELIEF PIPING**

Each chiller is equipped with pressure relief valves. The purpose of the relief valves is to quickly relieve excess pressure of the refrigerant charge as a safety precaution in the event of an emergency such as a fire. Sized to the requirements of applicable local codes, a vent line must be run from the relief valve to the outside of the building. Vent piping must be arranged to avoid imposing a strain on the relief valves and should include flexible connections.

The low side relief valve is located on the suction line. It has a pressure setting of 400 psig (27.6 bar) and a capacity of 26.8 lbs. air/min ( 166.3 l/s). The high side relief valve is located on the condenser shell. It has a pressure setting of 560 psig (38.6 bar) and a capacity of 49.8 lbs air/min (309.1 l/s).

The 0064, 0074, and 0096 units have additional relief valves on the discharge line(s) in lieu of compressor internal relief. The valve has a pressure setting of 650 psig (44.8 barg), a capacity of 44.6 lbs air/min (277.0 l/s) and a 1/2" flare connection.

# Guide Specifications

## PART 1 – GENERAL

### 1.01 SCOPE

- A. The requirements of the General Conditions, Supplementary Conditions, Division 1, and Drawings apply to all Work herein.
- B. Provide Microprocessor controlled, multiple-scroll compressor, water-cooled, liquid chillers of the scheduled capacities as shown and indicated on the Drawings, including but not limited to:
  - 1. Chiller package
  - 2. Electrical power and control connections
  - 3. Chilled water connections
  - 4. Charge of refrigerant and oil
  - 5. Factory start-up

### 1.02 QUALITY ASSURANCE

- A. Products shall be Designed, Tested, Rated and Certified in accordance with, and installed in compliance with applicable sections of the following Standards and Codes:
  - 1. ANSI/ASHRAE Standard 15 – Safety Code for Mechanical Refrigeration
  - 2. ASHRAE 90.1– Energy Efficiency compliance.
  - 3. ANSI/NFPA Standard 70 – National Electrical Code (N.E.C.)
  - 4. ASME Boiler & Pressure Vessel Code, Section VIII, Division 1
  - 5. ASHRAE 34 – Number Designation and Safety Classification of Refrigerants
  - 6. ARI Standard 550/590 – Positive Displacement Compressors and Water Cooled Rotary Screw Water-Chilling Packages
  - 7. Conform to UL code 1995 for construction of chillers and provide ETL/cETL Listing label
  - 8. Manufactured in facility registered to ISO 9001
  - 9. OSHA - Occupational Safety and Health Act
- B. Factory Test: Chiller shall be pressure-tested, evacuated and fully charged with refrigerant and oil, and shall be factory operational run tested with water flowing through the vessels.
- C. Chiller manufacturer shall have a factory trained and supported service organization that is within a 50 mile radius of the site.

## Guide Specifications (Cont'd)

- D. Warranty: Manufacturer shall Warrant all equipment and material of its manufacture against defects in workmanship and material for a period of one year from date of initial start-up or eighteen (18) months from date of shipment, whichever occurs first.

### 1.03 DELIVERY AND HANDLING

- E. Unit shall be delivered to job site fully assembled, and charged with refrigerant and oil by the Manufacturer.
- F. Unit shall be stored and handled per Manufacturer's instructions.
- G. Unit and its accessories shall be protected from the weather and dirt exposure during shipment.
- H. During shipment, a covering shall be provided over vulnerable components. Nozzles and open ends shall be fitted with plastic enclosures.

## PART 2 – PRODUCTS

### 2.01 CHILLER MATERIALS AND COMPONENTS

- I. General: Install and commission, as shown on the schedules and plans, factory assembled, charged, and tested water-cooled scroll compressor chiller(s) as specified herein. Chiller shall be designed, selected, and constructed using a refrigerant with Flammability rating of "1", as defined by ANSI/ASHRAE STANDARD - 34 Number Designation and Safety Classification of Refrigerants. Chiller shall include, but is not limited to: a complete system with not less than two refrigerant circuits, scroll compressors, direct expansion type evaporator, water-cooled condenser, refrigerant, lubrication system, interconnecting wiring, safety and operating controls including capacity controller, control center, motor starting components, and special features as specified herein or required for safe, automatic operation.

### 2.02 COMPRESSORS

- J. Compressors Shall be hermetic, scroll-type, including:
1. Compliant design for axial and radial sealing
  2. Refrigerant flow through the compressor with 100% suction cooled motor.
  3. Large suction side free volume and oil sump to provide liquid handling capability.
  4. Compressor crankcase heaters to provide extra liquid migration protection.
  5. Annular discharge check valve and reverse vent assembly to provide low pressure drop, silentshutdown and reverse rotation protection.
  6. Initial Oil charge.
  7. Oil Level sightglass.
  8. Vibration isolator mounts for compressors.
  9. Brazed-type connections for fully hermetic refrigerant circuits.
  10. Microprocessor controlled, Factory installed Across-the-Line type compressor motor starters.

## Guide Specifications (Cont'd)

### 2.03 REFRIGERANT CIRCUIT COMPONENTS

Each refrigerant circuit shall include: liquid line shutoff valve with charging port, low side pressure relief device, filter-drier, solenoid valve, discharge service valve, system high pressure relief device, sight glass with moisture indicator, expansion valves, and flexible, closed-cell foam insulated suction line.

### 2.04 HEAT EXCHANGERS

#### A. Evaporator:

1. Evaporator shall be a direct expansion shell and tube construction, dual circuit heat exchanger capable of refrigerant working pressure of 400 PSIG (27.6 bar) and liquid side pressure of 150 psig (10.3 bar).
2. Evaporator shall be covered with 3/4" (19mm), flexible, closed-cell insulation, thermal conductivity of 0.26k ([BTU/HR-Ft<sup>2</sup>-°F]/in.) maximum. Water nozzles shall be insulated by Contractor after pipe installation.
3. Heat exchangers shall be ASME pressure vessel code certified.
4. Installing contractor must include accommodations in the chilled water piping to allow proper drainage and venting of the heat exchanger.
5. The water connections shall be fully accessible and grooved to accept ANSI/AWWA C-606 couplings if used (by others).

#### B. Condenser:

1. Condenser shall be a cleanable thru-tube construction with removable heads and integral subcooling. Heat exchanger shall be capable of a refrigerant side working pressure of 560 PSIG (45 bar) and liquid side pressure of 150 psig (10.3 bar).
2. The condenser shall be equipped with relief valves and be capable of holding the full refrigerant charge for pumpdown.
3. The water connections shall be fully accessible and grooved to accept ANSI/AWWA C-606 couplings if used (by others).

### 2.05 CONTROLS

A. General: Automatic start, stop, operating, and protection sequences across the range of scheduled conditions and transients.

B. Microprocessor Enclosure: NEMA 1 (IP32) powder painted steel cabinet with hinged, latched, and gasket sealed door.

C. Microprocessor Control Center:

1. Automatic control of compressor start/stop, anti coincidence and anti-recycle timers, automatic pumpdown on shutdown, evaporator pump, and unit alarm contacts. Automatic reset to normal chiller operation after power failure.
2. Remote water temperature reset via a Pulse Width Modulated (PWM) input signal or up to two steps of demand (load) limiting.
3. Software stored in non-volatile memory, with programmed setpoints retained in lithium battery backed regulated time clock (RTC) memory for minimum 5 years.



## Guide Specifications (Cont'd)

4. Forty character liquid crystal display, numeric data in English (or Metric) units. Sealed keypad with sections for Setpoints, Display/Print, Entry, Unit Options & clock, and On/Off Switch. Display descriptions and membrane keypad graphics shown in English language.
  5. Programmable Setpoints (within Manufacturer limits): display language; chilled liquid temperature setpoint and range, remote reset temperature range, set daily schedule/holiday for start/ stop, manual override for servicing, number of compressors, low liquid temperature cutout, low suction pressure cutout, high discharge pressure cutout, anti-recycle timer (compressor start cycle time), and anti-coincident timer (delay compressor starts).
  6. Display Data: Return and leaving evaporator liquid temperatures, low leaving liquid temperature cutout setting, English or metric data, suction pressure cutout setting, each system suction pressure, discharge pressure, liquid temperature reset via a 0-20 VDC input, 2-10 VDC input or a 0-20mA input contact closure, anti-recycle timer status for each compressor, anti-coincident system start timer condition, compressor run status, no cooling load condition, day, date and time, daily start/ stop times, holiday status, automatic or manual system lead/lag control, lead system definition, compressor starts/operating hours (each), status of hot gas valves (if supplied), run permissive status, number of compressors running, liquid solenoid valve status, load & unload timer status, water pump status.
  7. System Safeties: Shall cause individual compressor systems to perform auto shut down; manual reset required after the third trip in 90 minutes. Includes: high discharge pressure, low suction pressure, high pressure switch, and motor protector. Compressor motor protector shall protect against damage due to high input current or thermal overload of windings.
  8. Unit Safeties: Shall be automatic reset and cause compressors to shut down if low ambient, low leaving chilled liquid temperature, under voltage, and flow switch operation. Contractor shall provide flow switch installation and wiring per chiller manufacturer requirements.
  9. Alarm Contacts: Low ambient, low leaving chilled liquid temperature, low voltage, low battery, and (per compressor circuit): high discharge pressure, and low suction pressure.
  10. BAS/EMS Temperature Reset: Chiller to accept 4 to 20mA, 0 to 10 VDC, or discrete contact closure input to reset the leaving chilled liquid temperature.
- D. Pressure Transducers and Readout Capability
1. Discharge Pressure Transducers: Permits unit to sense and display discharge pressure.
  2. Suction Pressure Transducers: Permits unit to sense and display suction pressure.
- E. Manufacturer shall provide any controls not listed above, necessary for automatic chiller operation. Mechanical Contractor shall provide field control wiring necessary to interface sensors to the chiller control system.

## Guide Specifications (Cont'd)

### 2.06 POWER CONNECTION AND DISTRIBUTION

#### A. Power Panels:

1. NEMA 1 (IP32), powder painted steel cabinets with hinged, latched, and gasket sealed outer doors. Provide main power connection(s), control power connections, compressor start contactors, current overloads, and factory wiring.
2. Power supply shall enter unit at a single location, be 3 phase of scheduled voltage, and connect to individual terminal blocks per compressor. Separate disconnecting means and/ or external branch circuit protection (by Contractor) required per applicable local or national codes.

B. Exposed compressor and control power wiring shall be routed through liquid tight conduit.

#### C. Power Supply Connection shall be:

1. Single Point Power Supply: Single point Terminal Block for field connection and interconnecting wiring to the compressors. Separate external protection must be supplied, by others, in the incoming power wiring, which must comply with the National Electric Code and/or local codes.

### 2.07 ACCESSORIES AND OPTIONS

Some accessories and options supersede standard product features. Your Johnson Controls sales representative will be pleased to provide assistance.

#### A. Power Supply Connections (Factory Mounted):

1. Single Point Disconnect Switch: Single point Non-Fused Disconnect and lockable external handle (in compliance with Article 440-14 of N.E.C.) can be supplied to isolate the unit power voltage for servicing. Separate external fusing must be supplied, by others, in the incoming power wiring, which must comply with the National Electric Code and/or local codes.
2. Single Point Circuit Breaker: Single point Terminal Block with Circuit Breaker and lockable external handle (in compliance with Article 440 14 of N.E.C.) can be supplied to isolate power voltage for servicing. Incoming power wiring must comply with the National Electric Code and/or local codes.
3. Multiple Point Circuit Breaker: Multiple point circuit breakers with lockable external handles (in compliance with Article 440-14 of N.E.C.) can be supplied to isolate power for servicing. Incoming power wiring must comply with the National Electric Code and/or local codes.

B. Control Power Transformer (Factory Mounted): Converts unit power voltage to 120-1-60 (500 VA capacity). Factory mounting includes primary and secondary wiring between the transformer and the control panel.

C. Flow Switch (Field-mounted): Vapor proof SPDT, NEMA 3R switch (150 PSIG), -20°F to 250°F. Available with evaporator.

D. Differential Pressure Switch (Field mounted): Alternative to the paddle-type flow switch. 3-45 PSIG (0.2-3 bar) range with ¼" NPTE pressure connections. Available with evaporator.

## Guide Specifications (Cont'd)

- E. Double Thick Evaporator Insulation (Factory Mounted): Evaporator covered with double thick (1-1/2") flexible, closed-cell Insulation in lieu of
- F. Standard (3/4") insulation. Water nozzles shall be insulated by Contractor after pipe installation.
- G. ANSI/AWWA C-606 Flange Kit (Field Mounted): ANSI/AWWA C-606 flange adapters included with the water connections on the evaporator and condenser providing raised face flanges for field piping connection (note: the 0056SE, 0064SE, 0064HE, 0074SE, and 0094SE units do not include condenser flanges).
- H. Service Isolation valves (Factory Mounted): Service suction (ball type) isolation valves are added to unit per circuit in addition to the standard discharge service valve. (Factory-mounted.)
- I. Hot Gas By-Pass (Factory Mounted): Permits continuous, stable operation at capacities below the minimum step of unloading to as low as 5% capacity (depending on both the unit & operating conditions) by introducing an artificial load on the evaporator. Hot gas by-pass is installed on only one refrigerant circuit (System #2).
- J. Microprocessor Membrane Keypad Graphics on in lieu of Standard English:
  - 1. Spanish language.
  - 2. French language.
  - 3. German language.
  - 4. Italian language.
- K. Chicago Code Relief Valves (Factory Mounted): Relief valves provided to meet Chicago Code requirements.
- L. Sound Reduction (Factory-mounted):
  - 1. Each compressors is individually enclosed in anacoustic sound blankets.
- M. Vibration Isolation (Field-mounted):
  - 1. Elastomeric Pad Isolators.
  - 2. 1 Inch Deflection Spring Isolators: Level adjustable, spring and cage type isolators for mounting under the unit base.
  - 3. 2 Inch Deflection Seismic Isolators: Level adjustable, restrained isolators, mounts in rugged welded steel housing with vertical and horizontal limit stops. Housings shall be designed to withstand a minimum 1.0g accelerated force in all directions to 2 inches.
- N. Final Paint Overspray: Overspray painting of assembled unit with Caribbean blue enamel.

## ***Guide Specifications (Cont'd)***

### **PART 3 – EXECUTION**

#### **3.01 INSTALLATION**

- A. General: Rig and Install in full accordance with Manufacturers requirements, Project drawings, and Contract documents.
- B. Location: Locate chiller as indicated on drawings, including cleaning and service maintenance clearance per Manufacturer instructions. Adjust and level chiller on support structure. If equipment provided exceeds height of scheduled chiller, installing contractor is responsible for additional costs associated with extending the height of parapet or screening walls/enclosures
- C. Components: Installing Contractor shall provide and install all auxiliary devices and accessories for fully operational chiller.
- D. Electrical: Coordinate electrical requirements and connections for all power feeds with Electrical Contractor.
- E. Controls: Coordinate all control requirements and connections with Controls Contractor.
- F. Finish: Installing Contractor shall paint damaged and abraded factory finish with touch-up paint matching factory finish.

# Notes

Printed on recycled paper

Form 150.26-EG1 (715) Supersedes: 150.26-EG1 (515)  
© 2015 Johnson Controls, Inc. P.O. Box 423, Milwaukee, WI 53201 Printed in USA  
[www.johnsoncontrols.com](http://www.johnsoncontrols.com)  
Issued on 7/23/2015

