

MODEL YLAA AIR-COOLED SCROLL CHILLERS WITH BRAZED PLATE HEAT EXCHANGERS STYLE B

55 – 175 TON
195 – 615 kW
60 Hz
R-410A



BY JOHNSON CONTROLS

Nomenclature

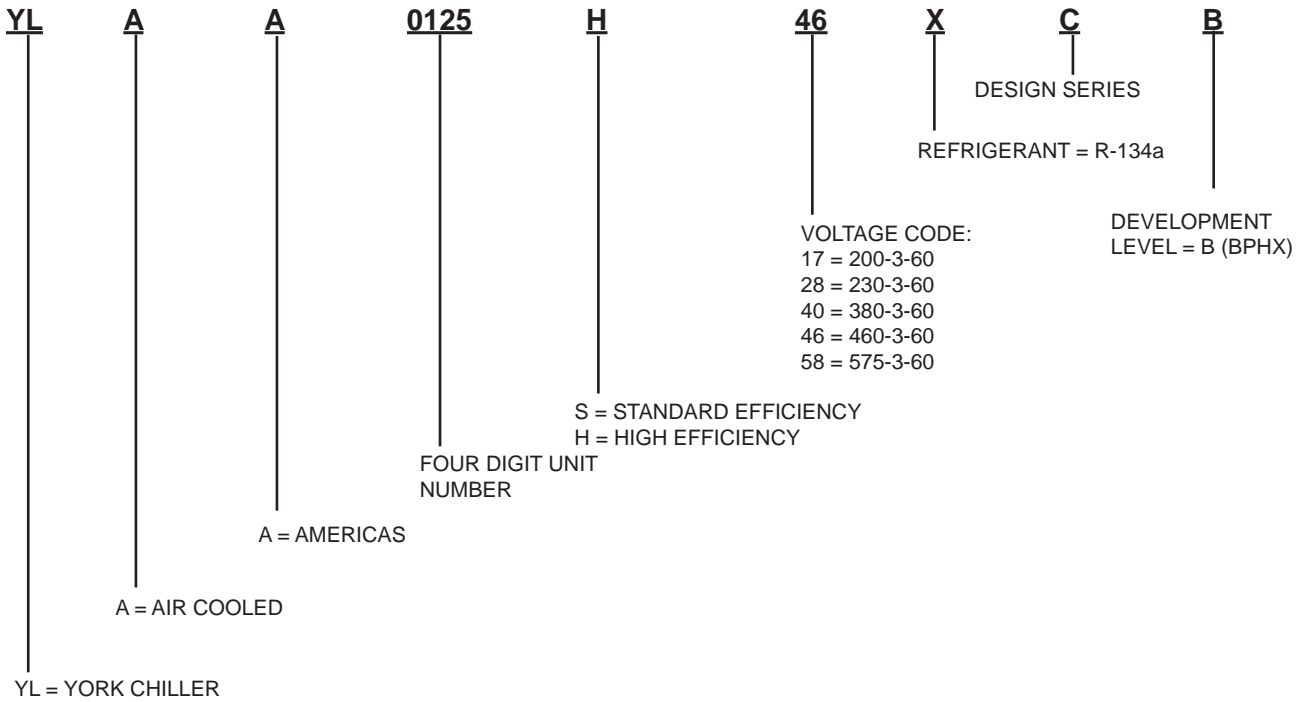

Approvals

- ASME Boiler and Pressure Vessel Code – Section VIII Division 1.
- AHRI Standard 550/590 and 551/591.
- UL 1995 – Heating and Cooling Equipment
- ASHRAE 15 – Safety Code for Mechanical Refrigeration
- ASHRAE Guideline 3 – Reducing Emission of Halogenated Refrigerants in Refrigeration and Air-Conditioning Equipment and Systems
- N.E.C. – National Electrical Code
- OSHA – Occupational Safety and Health Act



Products are produced at a facility whose quality-management systems are ISO9001 certified.

Table Of Contents

INTRODUCTION.....	5
EQUIPMENT OVERVIEW.....	8
UNIT COMPONENTS	15
ACCESSORIES AND OPTIONS	16
DESIGN PARAMETERS.....	20
WATER PRESSURE DROP.....	21
PHYSICAL DATA AND NOMINAL RATINGS.....	22
PART LOAD RATINGS.....	24
UNIT DIMENSIONS	26
ISOLATOR LOCATIONS	32
ISOLATOR DETAILS	36
ELECTRICAL NOTES	39
VARIABLE SPEED PUMP ELECTRICAL DATA.....	41
WIRING LUGS	42
ELECTRICAL DATA WITHOUT PUMPS.....	44
WIRING DIAGRAM.....	48
USER CONTROL WIRING	50
NOTES.....	51
APPLICATION DATA.....	53
GUIDE SPECIFICATIONS	55

Performance data provided in this document was created in accordance with Johnson Controls software: **YORKworks version 13.02 and DXCHILL version 6.04**

THIS PAGE INTENTIONALLY LEFT BLANK.

Introduction

Johnson Controls, the building efficiency leader, is proud to present the YORK Model YLAA Air-Cooled Scroll Chiller.

FEATURES AND BENEFITS

Installation

The YLAA chiller arrives as a factory-assembled package ready to be installed outdoors, either on the roof or at ground level. The air-cooled condensers eliminate the capital, installation and maintenance costs of a cooling-tower circuit.

The YLAA weighs less and has a smaller footprint than other chillers in its class. In fact, it is 20-35% lighter weight than the market average chiller. When the chiller is roof-mounted in new construction, the cost of the support structure can be reduced. In building retrofits, the YLAA can provide the largest capacity in a given space and existing structure.

Power hook-up could not be any easier with the standard single-point connection. A terminal block, disconnect switch or circuit breaker is provided to meet the unique needs of every project and minimize installation time and labor. The factory-installed control transformer steps down the power voltage to the control voltage.

Chilled-water piping is also simple. The water connections are factory-piped to the outside of the unit, for ease of access. Factory-cut grooves, or optional flanges, make piping connections simple. Optional factory-installed pump kits eliminate the time, cost, and mechanical-equipment room space necessary to install chilled-water pumps.

Press the start button with confidence – your YLAA has been run-tested at the factory to ensure that you will have a successful start-up.

Reliability

The YLAA chiller is proven and reliable, designed to reduce service calls. The scroll compressors have logged hundreds of thousands of operating hours in numerous different applications. The corrosive-resistant condenser heat exchangers have been specifically designed for stationary HVAC applications and have undergone extensive laboratory and field testing to extend chiller life and improve performance. They are also more rigid than standard condenser coils, making them less susceptible to damage during rigging, lifting, and installation of the chiller.

Components are designed to keep the chiller up-and-running. A factory-installed water strainer prevents debris from affecting unit flow and/or heat transfer. The rugged thermal-dispersion flow switch is factory-installed at the optimum location in the piping for superior flow sensing, reducing the potential for nuisance trips. Intelligent controls protect the chiller while keeping it online, for maximum uptime. Exterior panels of the chiller are powder-coated with highly durable corrosion-resistant paint.

Introduction (Cont'd)

Efficiency

YLAA high-efficiency chillers, with their innovative control algorithms, offer industry-leading energy efficiency. Real-world energy efficiency is measured by IPLV (off-design) performance, and YLAA chillers provide some of the best IPLVs in their class.

YLAA also offers an efficiency choice. In addition to the high-efficiency units, YLAA chillers are available in standard efficiency models with smaller footprints and lower capital costs.

Only pay for the chiller you need – the multi-efficiency levels of the YLAA allow you to decide the best investment for the job.

Flexibility

The YLAA chiller offers a number of options designed to operate reliably across a wide range of customer needs. It can cool glycol down to 10°F (-12°C). It can provide heat recovery up to 140°F (60°C), with up to 85% of total heat rejection captured.

When factory-mounted pump kits are considered, there are now more pump sizes to choose from. The optional kits come standard with valves, pressure ports, flow switch, and strainer for quick hook-up, and frost protection to prevent freeze-up. There are also more pump options available: variable-speed drives, dual pumps, service shut-off valves, expansion tanks, and additional test ports for temperature and pressure sensing.

Standard low sound and multiple sound attenuation options allow flexibility in locating the chiller, and reduce the cost for field-constructed barriers.

Sustainability

The YLAA makes you a leader in sustainability through innovation, not added cost. With the combination of R-410A refrigerant, which has no ozone-depletion potential, and state-of-the-art heat exchanger technology that allows refrigerant charge to be reduced by as much as 30%, the YLAA chiller provides the most ecologically friendly equipment. Partnered with its low-sound properties for noise pollution prevention, this chiller is a true earth-friendly offering.

Introduction (Cont'd)

Communications

The YLAA chiller comes standard with native communication capability for BACnet (MS/TP), Modbus, and N2, with optional capabilities available for LON. The standard unit capabilities include built-in-scheduling, remote start-stop, remote water temperature reset and up to two steps of demand (load) limiting depending on model. The standard control panel can be directly connected to a Johnson Controls Building Automated System via the standard factory-installed RS232 communication port.

Serviceability

Minimal maintenance is required to keep the unit operating at maximum performance. If service should ever be required, the YLAA chiller has been designed to simplify the work, keeping costs down. The layout of the chiller locates all the major components that can be serviced near the outside edge. The condenser heat exchangers are light enough that no crane is required for replacement. And when it's time to clean them, city tap water, with water pressure typical of a spray from a common garden hose, is all that's needed.

AHRI CERTIFICATION PROGRAM

YORK YLAA chillers have been tested and certified by Air-Conditioning, Heating and Refrigeration Institute (AHRI) in accordance with the latest edition of AHRI Standard 550/590 (I-P). Under this Certification Program, chillers are regularly tested in strict compliance with this Standard. This provides an independent, third-party verification of chiller performance. Refer to the AHRI site at: <http://www.ahrinet.org/> for complete Program Scope, Inclusions, and Exclusions as some options listed herein fall outside the scope of the AHRI certification program. For verification of certification, go to the AHRI Directory at www.ahridirectory.org.



Rated in accordance with the latest issuance of AHRI Standard 550/590 and 551/591.

Equipment Overview

The 55 - 175 Ton (195 - 615 kW) YLAA models are shipped complete from the factory ready for installation and use. The unit is pressure-tested, evacuated, and fully charged with a zero Ozone Depletion Potential Refrigerant R-410A and includes an initial oil charge. After assembly, a complete operational test is performed with water flowing through the evaporator to assure that the refrigeration circuit operates correctly.

The unit structure is heavy-gauge, galvanized steel. This galvanized steel is coated with baked-on powder paint, which, when subjected to ASTM B117 1000 hour, salt spray testing, yields a minimum ASTM 1654 rating of "6". Units are designed in accordance with NFPA 70 (National Electric Code), ASHRAE/ANSI 15 Safety code for mechanical refrigeration, ASME and rated in accordance with AHRI Standard 550/590 and 551/591.

COMPRESSORS

The chiller has suction-gas cooled, hermetic scroll compressors. The YLAA compressors incorporate a compliant scroll design in both the axial and radial direction. All rotating parts are statically and dynamically balanced. A large internal volume and oil reservoir provides greater liquid tolerance. Compressor-crankcase heaters are also included for extra protection against liquid migration.



LD18425

Equipment Overview (Cont'd)

BRAZED PLATE EVAPORATOR

The compact, high efficiency Brazed Plate Heat Exchanger (BPHE) is constructed with 316L stainless steel corrugated channel plates with a filler material between each plate. It offers excellent heat transfer performance with a compact size and low weight, reducing structural steel requirements on the job site.



LD18426

The heat exchanger is manufactured in a precisely controlled vacuum-brazing process that allows the filler material to form a brazed joint at every contact point between the plates, creating complex channels. The arrangement is similar to older plate and frame technology, but without gaskets and frame parts.

Water inlet and outlet connections are 3" in diameter and are grooved for compatibility with field supplied ANSI/AWWA C-606 couplings.

A 20 mesh wye-strainer is provided as standard to provide protection at the evaporator inlet, particularly at system start-up when construction debris may be present in the piping system.

The evaporator is equipped with a thermostat-controlled heater. The heater provides freeze protection for the evaporator down to -20°F (-29°C) ambient. The evaporator is covered with 3/4" flexible, closed-cell, foam insulation (K=0.25).

A factory-wired flow switch is standard, installed in a pipe section at the outlet of the evaporator.

Equipment Overview (Cont'd)

CANADIAN REGISTRATION NUMBER (CRN) APPLICATION & PROOF OF CONFORMANCE

Reference Table 1 for YLAA brazed plate evaporator Canadian Registration Numbers (CRN) for all Canadian Provinces. All YLAA brazed plate evaporators are categorized as pressure "H" fittings per CSA-B51.

TABLE 1 - CANADIAN REGISTRATION NUMBERS

CANADIAN PROVINCE	CRN#
BC	OH13953.51
AB	OH13953.52
ON	OH13953.5
PQ/MB/SK	OH13953.56
NB	OH13953.57
NS	OH13953.58
PEI	OH13953.59
NF	OH13953.50
NU	OH13953.5N
NWT	OH13953.5T
YU	OH13953.5Y

CONDENSER

Coils - Condenser coils are made of a single material to avoid galvanic corrosion due to dissimilar metals. Coils and headers are brazed as one piece. Integral sub cooling is included. The design working pressure of the coil is 650 PSIG (45 bar). Condenser coil is easily washable with clear water up to 100 psi (7 bar).



LD18427

Fans – The condenser fans are composed of corrosion resistant aluminum hub and glass-fiber-reinforced polypropylene composite blades molded into a low-noise airfoil section. They are designed for maximum efficiency and are statically and dynamically balanced for vibration-free operation. They are directly driven by independent motors, and positioned for vertical air discharge. The fan guards are constructed of heavy-gauge, rust-resistant, coated steel. All blades are statically and dynamically balanced for vibration-free operation.

Equipment Overview (Cont'd)



LD18428

Motors – The fans are driven by Totally Enclosed Air-Over, squirrel-cage type, current protected motors. They feature ball bearings that are double-sealed and permanently lubricated.

UNIT CONTROL SYSTEM

The YLAA chiller is designed with an intelligent control system that operates the chiller automatically with maximum reliability, safety and ease of use. The controls are factory tested and with as little user input as a chilled liquid setpoint the chiller will operate to meet the load demand.

The control system includes native BACnet MS/TP, Modbus and N2 communications, with LON protocol served through an optional eLink communications card.

The operating program is stored in non-volatile memory (EPROM), so power failures and battery discharge will not require reprogramming the chiller. Programmed setpoints are retained in lithium battery-backed RTC memory for 5 years minimum.

Unit alarm contacts are standard. Contacts for remote chilled liquid temperature reset and two steps of demand load limiting are also standard, for projects without BAS or for redundancy.

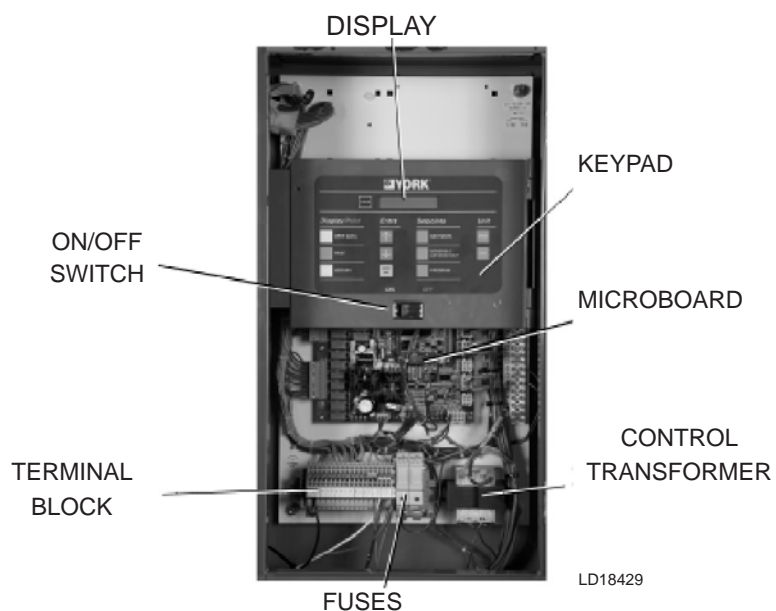

LD18429

Equipment Overview (Cont'd)

Maximum reliability is achieved through intelligent control. Run hours and starts are averaged across all compressors automatically, and between both pumps of the optional dual pump hydro-kit. When compressors are cycled off, an anti-recycle timer ensures the motors have time to cool before starting again, for the maximum service life. At unit shutdown, the unit pumps down automatically to prevent liquid refrigerant from entering the compressors at restart, which can cause premature bearing wear and other compressor damage.

Liquid temperature sensors provide feedback to the controller, and logic predicts when additional capacity will be required based on how quickly the unit has loaded or unloaded in the past. This prevents unnecessary compressor cycling and helps maintain setpoint accurately.

If there is a problem that prevents the unit operating properly, the controls are designed to allow the unit to operate safely while making as much capacity as possible. For example, if airflow to the condenser coil is diminished due to a dirty coil, the chiller will unload slightly to provide maximum capacity possible while remaining within the unit operating envelope.

If a fault prevents the unit from starting or causes it to shutdown, the chiller will attempt to restart three times. If it cannot start, a manual reset is required to alert the operator about the fault condition. The fault history is stored in the unit controller RTC memory for the last six fault shutdown conditions. An RS-232 port provides capability to print hard copy reports (printer available separately).

All controls are contained in a NEMA 3R cabinet with a hinged outer door and includes a liquid crystal display (LCD) with light emitting diode (LED) backlighting for outdoor viewing. There are two display lines, each with twenty text characters per line, and a color coded 12-button non-tactile keypad with sections for display, entry and printing.

DISPLAY/PRINT provides quick access to frequently needed information:

- Chilled liquid temperatures
- Ambient temperature
- System pressures (each circuit)
- Operating hours and starts (each compressor)
- Operating data for the systems

ENTRY section allows entering setpoints or modifying system values.

SETPOINTS updating can be performed to:

- Chilled liquid temperature setpoint and range
- Remote reset temperature range
- Set daily schedule/holiday for start/stop
- Manual override for servicing
- Low and high ambient cut-outs

Equipment Overview (Cont'd)

- Number of compressors
- Low liquid temperature cut-out
- Low suction pressure cut-out
- High discharge pressure cut-out
- Anti-recycle timer (compressor start cycle time)
- Anti-coincident timer (delay compressor starts)

UNIT section to:

- Set time
- Set unit options

In addition, the microprocessor control center is capable of displaying the following data points:

- Return and leaving liquid temperature
- Low leaving liquid temperature cut-out setting
- Low ambient temperature cut-out setting
- Outdoor air temperature
- English or Metric data
- Suction pressure cut-out setting
- Each system suction pressure
- Discharge pressure (optional)
- Anti-recycle timer status for each system
- Anti-coincident system start timer condition
- Compressor run status
- No cooling load condition
- Day, date and time
- Daily start/stop times
- Holiday status
- Automatic or manual system lead/lag control
- Lead system definition
- Compressor starts & operating hours (each compressor)
- Status of hot gas valves, evaporator heater and fan operation
- Run permissive status

Equipment Overview (Cont'd)

- Number of compressors running
- Liquid solenoid valve status
- Load & unload timer status
- Water pump status

COMMUNICATIONS

- Native communication capability for BACnet (MS/TP), Modbus and N2
- Optional communication available for LON via eLink option

BUILDING AUTOMATION SYSTEM INTERFACE

In addition to native BACnet, Modbus and N2, the YLAA chiller accepts a 4-20 milliamp or 0-10VDC input to reset of the leaving chilled liquid temperature. The standard unit capabilities include remote start-stop, remote water temperature reset via up to two steps of demand (load) limiting depending on model. The standard control panel can be directly connected to a Johnson Controls Building Automated System via the standard on-board RS232 communication port. (Factory- installed)

POWER PANEL

- Each panel contains:
 - Compressor power terminals
 - Compressor motor starting contactors per I.E.C.
 - Control power terminals to accept incoming for 115-1-60 control power
 - Fan contactors & overload current protection

The power wiring is routed through liquid-tight conduit to the compressors and fans.

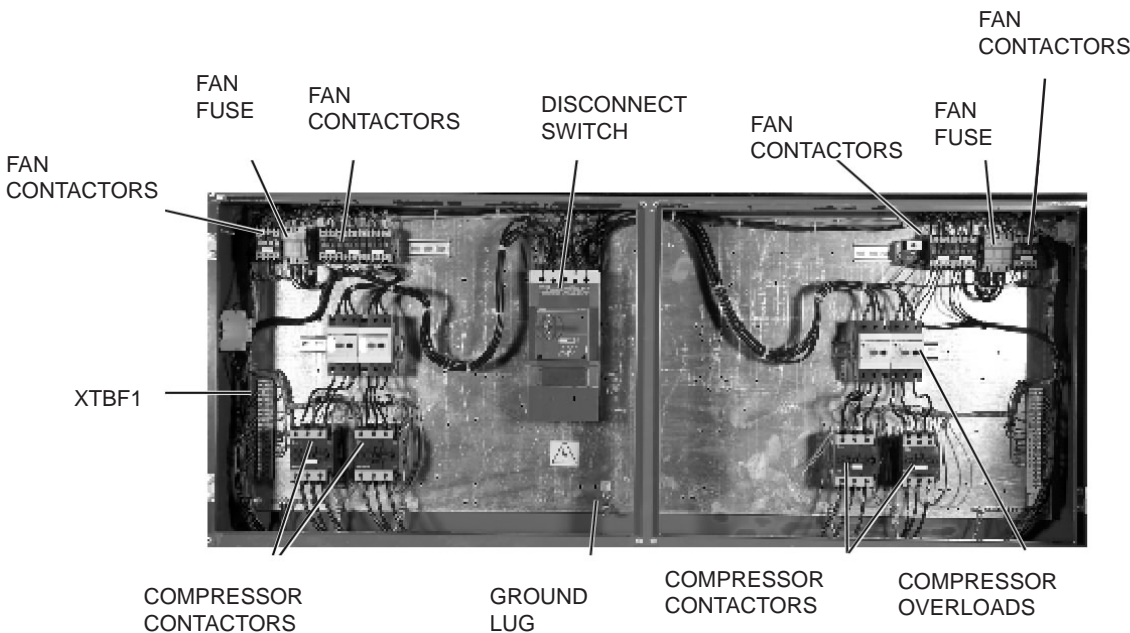

LD18430

Unit Components

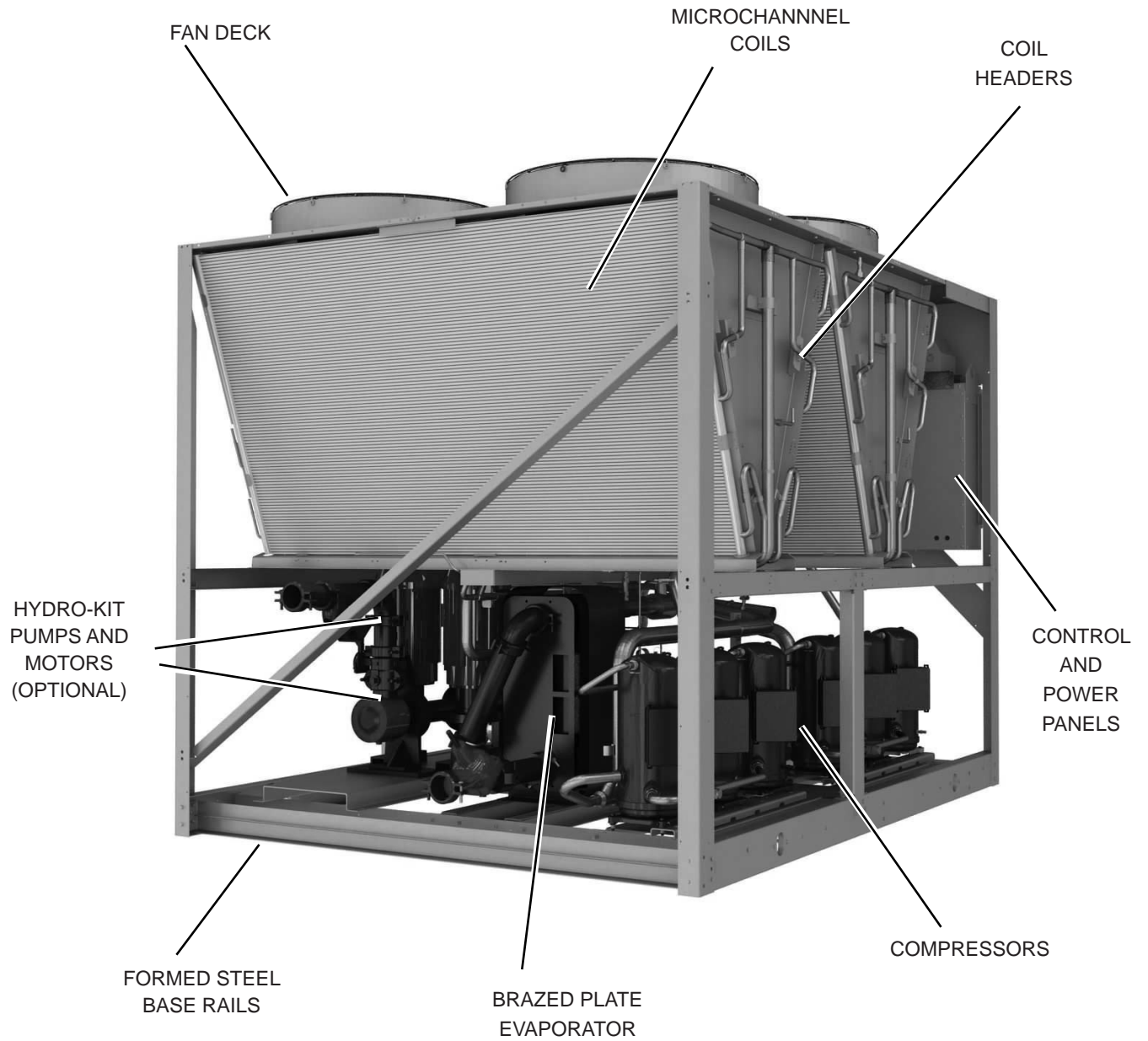

LD18426

FIGURE 1 - GENERAL UNIT COMPONENTS

Accessories and Options

All options are factory installed unless otherwise noted.

POWER OPTIONS:

Unit Power Connections – Single-point terminal block connection(s) are provided as standard. The following power connections are available as options. (See electrical data for specific voltage and options availability.)

Single-Point Supply Terminal Block – Includes enclosure, terminal-block and interconnecting wiring to the compressors. Separate external protection must be supplied, by others, in the incoming compressor-power wiring. (Do not include this option if either the Single-Point Non-Fused Disconnect Switch or Single-Point Circuit Breaker options have been included.)

Single-Point Non-Fused Disconnect Switch – Unit-mounted disconnect switch(es) with external, lockable handle (in compliance with Article 440-14 of N.E.C.) can be supplied to isolate the unit power voltage for servicing. Separate external fusing must be supplied, by others in the power wiring, which must comply with the National Electrical Code and/or local codes.

Single-Point Circuit Breaker – A unit mounted circuit breaker with external, lockable handle (in compliance with NEC Article 440-14), can be supplied to isolate the power voltage for servicing. (This option includes the Single-Point Power connection.)

Multiple Point Supply With Individual System Circuit Breakers – Two unit-mounted circuit breakers, with external lockable handles (in compliance with NEC Article 440-14), can be supplied to isolate the power voltage for servicing. **(SQ only)**

Control Transformer – Converts unit power voltage to 115-1-60 (0.5 or 1.0 kVA capacity). Factory mounting includes primary and secondary wiring between the transformer and the control panel.

Power Factor Correction Capacitors – Will correct unit compressor power factors to a 0.90-0.95.

CONTROL OPTIONS:

High Ambient Kit – Allows units to operate when the ambient temperature is above 115°F (46°C). Includes sun shield panels and discharge pressure transducers.

Low Ambient Kit – Standard units will operate to 30°F (-1°C). This accessory includes all necessary components to permit chiller operation to 0°F (-18°C). (This option includes the discharge pressure transducer/readout capability option.) For proper head pressure control in applications below 30°F (-1°C) where wind gusts may exceed 5 mph, it is recommended that optional condenser louvered enclosure panels also be included.

Language LCD and Keypad Display – Spanish, French, German, and Italian unit LCD controls and keypad display available. Standard language is English.

Accessories and Options (Cont'd)

COMPRESSOR, PIPING, EVAPORATOR OPTIONS:

Low Temperature Glycol – Replaces standard Thermostatic Expansion Valves with Electronic Expansion Valves to achieve leaving glycol temperatures as low as 10°F (-12°C). Required for any leaving liquid temperature below 30°F (-1°C). Electronic Expansion Valves permit operation at both low temperatures and comfort cooling applications without a capacity loss or derate at either condition.

Chicago Code Relief Valves – Unit will be provided with relief valves to meet Chicago code requirements.

Service Suction Isolation Valve – Service suction discharge (ball-type) isolation valves are added to unit per system (discharge service ball-type isolation valve is standard on each circuit).

Hot Gas By-Pass – Permits continuous, stable operation at capacities below the minimum step of compressor unloading to as low as 5% capacity (depending on both the unit and operating conditions) by introducing an artificial load on the evaporator. Hot gas by-pass is installed on only refrigerant system #1.

Thermal Dispersion Flow Switch – A thermal dispersion type flow switch provides accurate, low maintenance flow proving and is included standard. It is factory wired and installed in the extension pipe between evaporator outlet and edge of chiller. The extension pipe is secured to the chiller frame for shipping to avoid risk of damage to evaporator and is easily attached to the evaporator at startup using the supplied ANSI/AWWA C-606 connector. The flow switch can be deleted if alternate or existing flow switch is field supplied.

Evaporator Nozzle Extension Kit – Pipe and ANSI/AWWA C-606 fittings to extend the evaporator connections to the outside of the chiller. Includes the Thermal Dispersion Flow Switch. Provided as standard on all chillers but can be deleted if alternate or existing piping and flow switch is field supplied. The extension pipe is secured to the chiller frame for shipping to avoid risk of damage to evaporator and is easily attached to the evaporator at startup using the supplied ANSI/AWWA C-606 connector. A support bracket for the extension kit or field piping is standard on all chillers. Extension kit insulation and heat trace to be field provided if required.

Heat Recovery Condenser – A partially condensing refrigerant to liquid condenser recovers heat off both refrigerant circuits and rejects into a single liquid circuit. Factory installed between the compressor discharge and the condenser (air) coils to capture the maximum amount of heat. Capable of recovering up to 85% total heat of rejection (cooling load plus work input); temperatures as high as 140°F (60°C) are possible.

Hydro-Kit – Factory installed Hydro-Kit suitable for water glycol systems with up to 35% glycol at leaving temperatures down to 20°F. The hydro-kit option is available in a single or dual configuration (dual as standby duty only), with totally enclosed permanently lubricated pump motors.

The hydro-kit comes standard with a variable speed drive, a balancing valve, discharge check valve, discharge shutoff valve, thermal dispersion flow switch, pressure ports, inlet wye-strainer, bleed and drain valves and frost protection.

Service shut off valves, additional pressure ports and taps for the expansion tank are optional within the hydro-kit option. Expansion tanks are available by request.

Accessories and Options (Cont'd)

CONDENSER AND CABINET OPTIONS:

Condenser coil protection against corrosive environments is available by choosing any of the following options. For additional application recommendations, refer to FORM 150.12-ES1.

Post-Coated Condenser Coils – The unit is built with electrostatic post-coated condenser coils. This is the choice for corrosive applications (with the exception of strong alkalis, oxidizers and wet bromine, chlorine and fluorine in concentrations greater than 100 ppm).

Enclosure Panels (Unit) – Tamperproof enclosure panels prevent unauthorized access to units. Enclosure panels can provide an aesthetically pleasing alternative to expensive fencing. Additionally, for proper head pressure control, Johnson Controls recommends the use of Condenser Louvered Panels for winter applications where wind gusts may exceed five miles per hour (8 kph). The following types of enclosure panels are available:

Wire Panels (Full Unit) – Consists of welded wire-mesh guards mounted on the exterior of the unit. Prevents unauthorized access, yet provides free air flow.

Wire/Louvered Panels – Consists of welded wire-mesh panels on the bottom part of unit and louvered panels on the condenser section of the unit. **(Factory-mounted)**.

Louvered Panels (Condenser Coil Only) – Louvered panels are mounted on the sides and ends of the condenser coils for protection.

Louvered Panels (Full Unit) – Louvered panels surround the front, back, and sides of the unit. They prevent unauthorized access and visually screen unit components. Unrestricted air flow is permitted through generously sized louvered openings. This option is applicable for any outdoor design ambient temperature up to 115°F (46°).

Coil End Hail Guard – Louvered panel attached to exposed coil end.

Accessories and Options (Cont'd)

SOUND ATTENUATION:

One or both of the following sound attenuation options are recommended for residential or other similar sound sensitive locations.

Compressor Acoustic Sound Blanket – Each compressor is individually enclosed by an acoustic sound blanket. The sound blankets are made with one layer of acoustical absorbent textile fiber of 5/8" (15mm) thickness; one layer of heavy duty anti-vibration material thickness of 1/8" (3mm). Both are closed by two sheets of welded PVC, reinforced for temperature and UV resistance.

Ultra Quiet Fans – Lower RPM, 8-pole fan motors are used with steeper-pitch fans.

Variable Speed Fans - Controls all the fans on the circuit. There is a drive installed for each circuit. Available on both low sound and ultra quiet fans.

VIBRATION ISOLATION

Vibration Isolators – Level adjusting, spring type 1" (25.4mm), 2" (50.8 mm) deflection, or neoprene isolators for mounting under unit base rails. **(Field installed)**

Design Parameters

NOMINAL EVAPORATOR WATER FLOW						
YLAA	TEMPERATURE (°F)		WATER FLOW (GPM)		AIR ON CONDENSER (°F)	
	MIN ¹	MAX ²	MIN	MAX	MIN ³	MAX ⁴
STANDARD EFFICIENCY						
0070SE	40	55	60	285	0	125
0080SE	40	55	100	355	0	125
0089SE	40	55	100	385	0	125
0100SE	40	55	100	385	0	125
0120SE	40	55	150	625	0	125
0136SE	40	55	150	625	0	125
0155SE	40	55	150	625	0	125
0170SE	40	55	150	625	0	125
HIGH EFFICIENCY						
0058HE	40	55	60	285	0	125
0065HE	40	55	60	285	0	125
0081HE	40	55	150	625	0	125
0092HE	40	55	100	385	0	125
0101HE	40	55	100	385	0	125
0125HE	40	55	100	385	0	125
0142HE	40	55	150	625	0	125
0156HE	40	55	150	625	0	125
0175HE	40	55	150	625	0	125

NOTES:

1. For leaving liquid temperature below 40°F (4°C) (to 10°F [-12°C]) optional low temperature glycol kit required. Contact your nearest Johnson Controls Office for application requirements.
2. For leaving liquid temperature higher than 55°F (13°C), contact the nearest Johnson Controls Office for application guidelines.
3. The evaporator is protected against freezing to -20°F (-29°C) with an electric heater as standard.
4. For operation at temperatures above 115°F (46°C), the optional High Ambient Kit will need to be installed on the system.

Water Pressure Drop

YLAA EVAPORATOR PRESSURE DROP CURVE

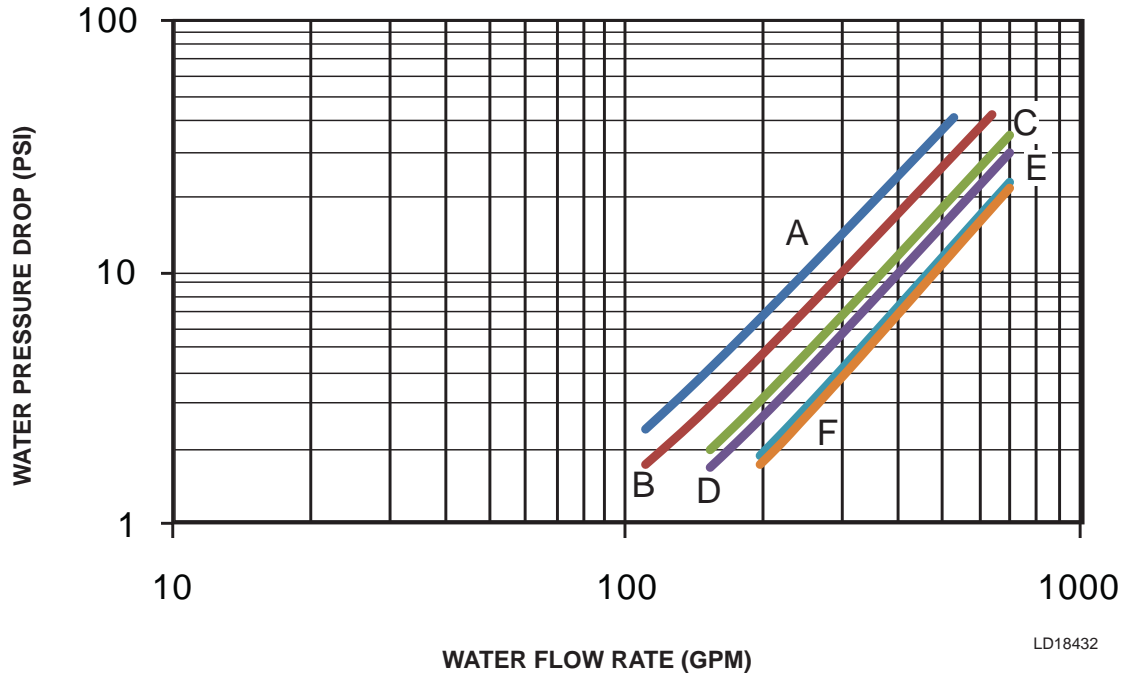

EVAPORATOR	YLAA MODELS
A	0058HE, 0065HE, 0070SE
B	0080SE
C	0089SE, 0100SE, 0092HE, 0101HE, 0125HE
D	0081HE, 0136SE, 0170SE, 0156HE
E	0120SE, 0155SE, 0142HE
F	0175HE

Physical Data and Nominal Ratings

REFRIGERANT R-410A	YLAA							
	STANDARD EFFICIENCY UNITS							
	0070SE	0080SE	0089SE	0100SE	0120SE	0136SE	0155SE	0170SE
NOMINAL RATINGS								
TONS	71.0	77.8	81.8	95.6	118.1	126.1	143.0	167.4
KW	77.5	86.3	93.0	111.5	134.6	142.6	165.0	192.1
EER	10.1	10.0	9.8	9.6	9.8	9.7	9.8	9.6
IPLV	16.1	15.6	15.7	14.5	15.0	15.8	15.9	15.6
GENERAL UNIT DATA								
Length	116.1	116.1	116.1	142.7	142.7	187.7	187.7	232.7
Width	88	88	88	88	88	88	88	88
Height	94.2	94.2	94.2	94.2	94	94.2	94.2	94.2
Number of Refrigerant Circuits	2	2	2	2	2	2	2	2
REFRIGERANT CHARGE, OPERATING								
R-410A, Circuit 1 / Circuit 2, lbs	43/43	47/44	57/57	55/58	54/62	75/71	75/70	90/87
Oil Charge, Circuit 1 / Circuit 2, gallons	2.58/2.58	3.28/2.58	3.28/2.76	3.28/3.33	3.33/3.33	4.99/2.76	4.99/3.33	4.99/4.99
Shipping Weight	3578	3898	4168	4791	5183	6148	6414	7734
Operating Weight	3623	3954	4241	4864	5293	6232	6524	7818
COMPRESSORS, SCROLL TYPE								
Compressors per circuit	3/3	3/3	3/3	3/2	2/2	3/3	3/2	3/3
Compressors per unit	6	6	6	5	4	6	5	6
NOMINAL TONS PER COMPRESSOR								
Circuit 1	13	15	15	15	32	32	32	32
Circuit 2	13	13	15	32	32	15	32	32
CONDENSER								
Total Face Area ft ²	106.9	106.9	106.9	133.6	160.3	213.8	213.8	267.2
Number of Rows	1	1	1	1	1	1	1	1
Fins per Inch	20	20	20	20	20	20	20	20
CONDENSER FANS, LOW SOUND								
Number of Fans, Circuit 1 / Circuit 2	2/2	2/2	2/2	3/2	3/3	4/4	4/4	5/5
Fan hp	2	2	2	2	2	2	2	2
Fan RPM	1160	1160	1160	1160	1160	1160	1160	1160
Total Chiller CFM	62400	62400	62400	78000	93600	124800	124800	156000
EVAPORATOR								
Water Volume, Gallons	5.4	6.7	8.8	8.8	13.2	10.0	13.2	10.0
Maximum Water Side Pressure, Psig	150	150	150	150	150	150	150	150
Maximum Refrigerant Side Pressure, Psig	450	450	450	450	450	450	450	450
Minimum Chiller Water Flow Rate, Gpm	60	100	140	100	150	150	150	150
Maximum Chiller Water Flow Rate, Gpm	285	355	385	385	625	625	625	625
Water Connections Size, Inches	3	3	3	3	3	4*	4*	4*

* Side extension kit (standard), evaporator nozzle remains 3".

Physical Data and Nominal Ratings (Cont'd)

REFRIGERANT R-410A	YLAA								
	HIGH EFFICIENCY UNITS								
	0058HE	0065HE	0081HE	0092HE	0101HE	0125HE	0142HE	0156HE	0175HE
NOMINAL RATINGS									
TONS	57.0	62.3	79.8	85.7	98.3	116.0	129.5	144.5	172.5
KW	64.4	71.9	91.0	83.6	106.1	122.0	138.9	153.0	194.2
EER	10.6	10.4	10.4	11.0	10.1	10.3	10.2	10.2	9.8
IPLV	15.6	15.6	16.1	16.1	15.7	15.7	15.9	15.5	15.6
GENERAL UNIT DATA									
Length	100.2	100.2	100.2	142.7	142.7	187.7	187.7	232.7	232.7
Width	88.0	88.0	88.0	88	88	88	88	88	88
Height	94.2	94.2	94.2	94.2	94.2	94.2	94.2	94.2	94.2
Number of Refrigerant Circuits	2	2	2	2	2	2	2	2	2
REFRIGERANT CHARGE, OPERATING									
R-410A, Circuit 1 / Circuit 2, lbs	43/43	43/43	44/44	59/55	45/65	75/71	83/73	90/82	94/92
Oil Charge, Circuit 1 / Circuit 2, gallons	2.58/2.58	2.89/2.58	2.58/2.58	2.76/2.76	3.28/3.33	3.33/3.33	4.99/2.76	4.99/3.33	4.99/4.99
Shipping Weight	3508	3704	4061	4718	4953	5869	6259	7344	7882
Operating Weight	3552	3748	4145	4791	5026	5942	6369	7428	8001
COMPRESSORS, SCROLL TYPE									
Compressors per circuit	2/2	3/2	3/3	3/3	3/2	2/2	3/3	3/2	3/3
Compressors per unit	4	5	6	6	5	4	6	5	6
NOMINAL TONS PER COMPRESSOR									
Circuit 1	15	13	15	15	15	32	32	32	32
Circuit 2	15	15	13	15	32	32	15	32	32
CONDENSER									
Total Face Area ft ²	106.9	106.9	106.9	160.3	160.3	213.8	213.8	267.2	267.2
Number of Rows	1	1	1	1	1	1	1	1	1
Fins per Inch	20	20	20	20	20	20	20	20	20
CONDENSER FANS, LOW SOUND									
Number of Fans, Circuit 1 / Circuit 2	2/2	2/2	2/2	3/3	4/2	4/4	5/3	6/4	5/5
Fan hp	2	2	2	2	2	2	2	2	2
Fan RPM	1160	1160	1160	1160	1160	1160	1160	1160	1160
Total Chiller CFM	62400	62400	62400	93600	93600	124800	124800	156000	156000
EVAPORATOR									
Water Volume, Gallons	5.4	5.4	10	8.8	8.8	8.8	13.2	10.0	14.3
Maximum Water Side Pressure, PSIG	150	150	150	150	150	150	150	150	150
Maximum Refrigerant Side Pressure, PSIG	450	450	450	450	450	450	450	450	450
Minimum Chiller Water Flow Rate, GPM	60	60	150	100	100	100	150	150	150
Maximum Chiller Water Flow Rate, GPM	285	285	625	385	385	385	625	625	625
Water Connections Size, Inches	3	3	3	3	3	4*	4*	4*	4*

* Side extension kit (standard), evaporator nozzle remains 3".

Part Load Ratings

STANDARD EFFICIENCY

YLAA0070SE				
% DISPL.	TONS	COMPR. KW	AMBIENT (°F)	UNIT EER
100.0	71.0	75.5	95.0	10.4
83.3	62.8	56.2	88.1	12.0
66.7	53.7	39.4	80.4	14.0
50.0	42.1	26.4	70.5	16.0
33.3	29.2	15.6	59.6	18.5
16.7	14.4	7.4	55.0	19.1
IPLV 16.1				

YLAA0080SE				
% DISPL.	TONS	COMPR. KW	AMBIENT (°F)	UNIT EER
100.0	77.8	86.3	95.0	10.0
83.6	69.5	68.2	88.6	11.1
66.7	59.2	46.2	80.6	13.4
50.3	47.3	32.3	71.5	15.2
33.3	32.0	17.9	59.7	18.1
16.9	16.9	9.1	55.0	18.9
IPLV 15.6				

YLAA0089SE				
% DISPL.	TONS	COMPR. KW	AMBIENT (°F)	UNIT EER
100.0	81.8	93.0	95.0	9.8
83.3	72.6	69.7	88.2	11.4
66.7	62.3	48.7	80.7	13.5
50.0	49.1	31.8	71.0	15.3
33.3	33.3	18.5	59.1	18.3
16.7	16.4	8.6	55.0	19.1
IPLV 15.7				

YLAA0100SE				
% DISPL.	TONS	COMPR. KW	AMBIENT (°F)	UNIT EER
100.0	95.6	111.5	95.0	9.6
86.1	86.5	88.5	89.3	10.7
57.0	64.5	45.4	75.5	14.4
43.0	47.4	34.4	64.7	15.1
13.9	16.0	8.5	55.0	18.7
IPLV 14.5				

YLAA0120SE				
% DISPL.	TONS	COMPR. KW	AMBIENT (°F)	UNIT EER
100.0	118.1	134.6	95.0	9.8
75.0	96.6	84.1	84.1	12.3
50.0	71.0	43.1	71.1	16.0
25.0	33.0	22.0	55.0	16.7
IPLV 15.0				

YLAA0136SE				
% DISPL.	TONS	COMPR. KW	AMBIENT (°F)	UNIT EER
100.0	126.1	142.6	95.0	9.7
83.3	108.0	91.9	86.4	12.3
66.7	95.7	73.7	80.5	13.4
50.0	67.3	41.5	67.0	16.7
33.3	52.1	27.8	59.8	18.1
16.7	35.0	18.4	55.0	19.3
IPLV 15.8				

YLAA0155SE				
% DISPL.	TONS	COMPR. KW	AMBIENT (°F)	UNIT EER
100.0	143.0	165.0	95.0	9.8
80.0	127.2	112.3	87.3	12.1
60.0	101.5	71.3	76.7	14.4
40.0	70.0	41.0	63.8	17.6
20.0	35.0	18.4	55.0	19.3
IPLV 15.9				

YLAA0170SE				
% DISPL.	TONS	COMPR. KW	AMBIENT (°F)	UNIT EER
100.0	167.4	192.1	95.0	9.6
83.3	148.5	142.3	88.2	11.2
66.7	127.9	98.8	80.8	13.3
50.0	101.5	64.3	71.4	15.0
33.3	69.5	38.9	59.9	18.3
16.7	34.5	18.2	55.0	19.2
IPLV 15.6				

Part Load Ratings (Cont'd)

HIGH EFFICIENCY

YLAA0058HE				
% DISPL.	TONS	COMPR. KW	AMBIENT (°F)	UNIT EER
100.0	57.0	57.7	95.0	10.6
75.0	46.2	36.6	83.7	12.8
50.0	32.4	20.9	69.1	16.0
25.0	16.6	8.8	55.0	19.0
IPLV 15.6				

YLAA0125HE				
% DISPL.	TONS	COMPR. KW	AMBIENT (°F)	UNIT EER
100.0	116.0	112.0	95.0	10.3
75.0	94.6	76.8	83.9	12.6
50.0	67.2	43.5	69.7	16.0
25.0	34.9	18.3	55.0	19.3
IPLV 15.7				

YLAA0065HE				
% DISPL.	TONS	COMPR. KW	AMBIENT (°F)	UNIT EER
100.0	62.3	65.2	95.0	10.4
80.0	54.3	46.8	87.3	12.2
60.0	42.5	28.9	75.9	14.3
40.0	30.0	17.7	63.9	17.1
20.0	13.8	7.3	55.0	18.5
IPLV 15.6				

YLAA0142HE				
% DISPL.	TONS	COMPR. KW	AMBIENT (°F)	UNIT EER
100.0	129.5	138.9	95.0	10.2
83.3	109.7	90.1	85.8	12.7
66.7	97.4	71.1	80.1	13.8
50.0	67.4	39.6	66.2	16.9
33.3	51.4	27.1	58.8	18.3
16.7	34.4	18.1	55.0	19.2
IPLV 15.9				

YLAA0081HE				
% DISPL.	TONS	COMPR. KW	AMBIENT (°F)	UNIT EER
100.0	78.8	84.3	95.0	10.4
83.6	70.2	64.9	88.4	11.8
66.7	59.5	43.9	80.3	14.1
50.3	47.7	30.2	71.3	15.5
33.3	31.7	16.9	59.2	18.8
16.7	16.8	8.6	55.0	19.6
IPLV 16.1				

YLAA0156HE				
% DISPL.	TONS	COMPR. KW	AMBIENT (°F)	UNIT EER
100.0	144.5	153.0	95.0	10.2
80.0	124.8	108.4	86.8	12.0
60.0	97.8	72.4	75.6	14.2
40.0	70.4	39.9	64.2	16.9
20.0	34.6	18.5	55.0	19.0
IPLV 15.5				

YLAA0092HE				
% DISPL.	TONS	COMPR. KW	AMBIENT (°F)	UNIT EER
100.0	85.7	83.6	95.0	11.0
83.3	74.9	64.0	87.4	12.4
66.7	62.7	46.3	78.9	14.2
50.0	48.7	30.9	69.1	16.3
33.3	33.2	17.7	58.3	18.9
16.7	16.3	8.1	55.0	19.4
IPLV 16.1				

YLAA0175HE				
% DISPL.	TONS	COMPR. KW	AMBIENT (°F)	UNIT EER
100.0	172.5	194.2	95.0	9.8
83.3	152.6	143.5	88.1	11.4
66.7	130.8	99.2	80.5	13.5
50.0	102.7	64.2	70.7	15.2
33.3	69.2	38.6	59.1	18.3
16.7	34.1	18.3	55.0	18.9
IPLV 15.6				

YLAA0101HE				
% DISPL.	TONS	COMPR. KW	AMBIENT (°F)	UNIT EER
100.0	98.3	106.1	95.0	10.1
86.1	89.3	82.8	89.5	11.5
57.0	65.6	43.7	75.1	14.6
43.0	50.3	30.5	65.7	17.0
13.9	16.0	8.5	55.0	19.0
IPLV 15.7				

Unit Dimensions

YLAA0058HE, YLAA0065HE, YLAA0081HE

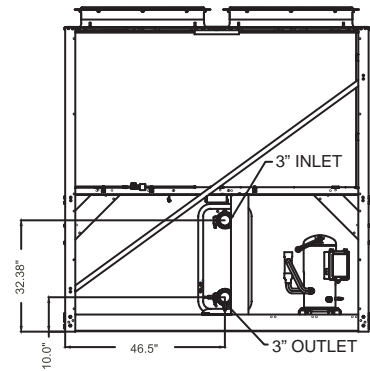
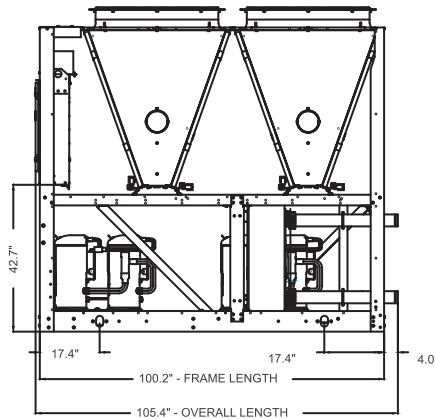
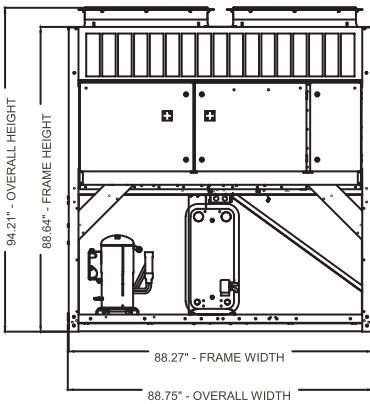
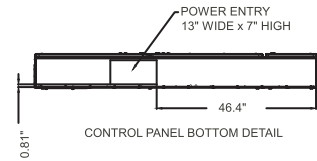
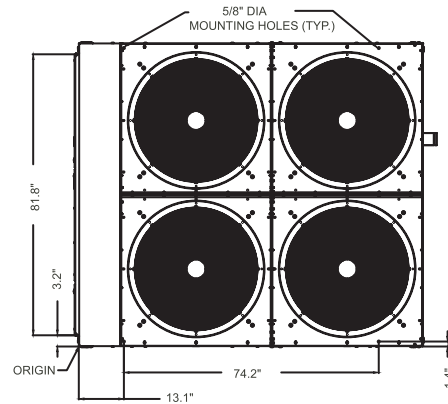

LD18432

NOTE:

Placement on a level surface of free of obstructions (including snow, for winter operation) or air circulation ensures rated performance, reliable operation, and ease of maintenance. Site restrictions may compromise minimum clearances indicated below, resulting in unpredictable airflow patterns and possible diminished performance. The unit controls will optimize operation without nuisance high-pressure safety cut-outs; however, the system designer must consider potential performance degradation. Access to the unit control center assumes the unit is no higher than on spring isolators. Recommended minimum clearances: Side to wall – 6'; rear to wall – 6'; control panel to end wall – 4'0"; top – no obstructions allowed; distance between adjacent units – 10'. No more than one adjacent wall may be higher than the unit.

Unit Dimensions (Cont'd)

YLAA0070SE, YLAA0080SE, YLAA0089SE

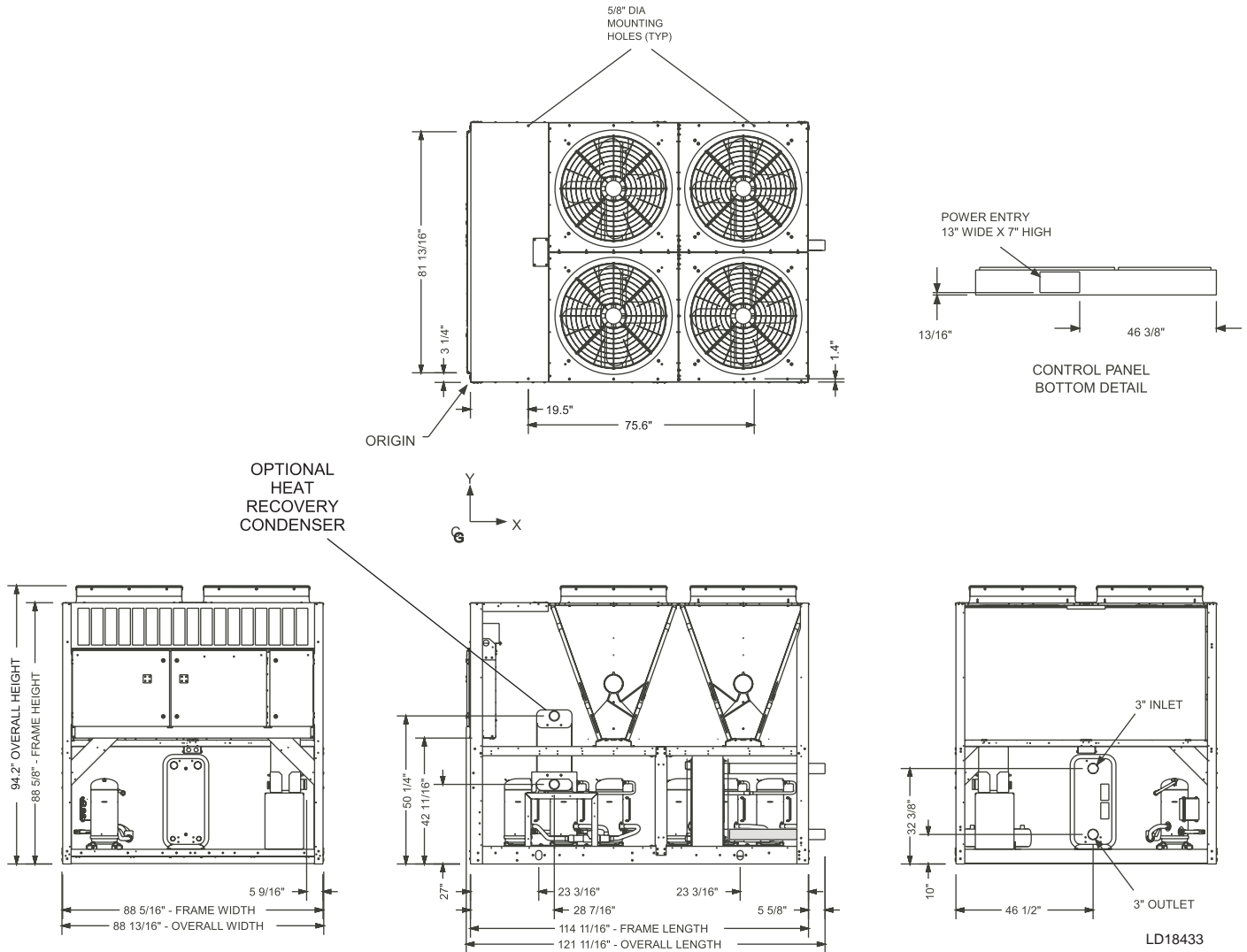

NOTE:

Placement on a level surface of free of obstructions (including snow, for winter operation) or air circulation ensures rated performance, reliable operation, and ease of maintenance. Site restrictions may compromise minimum clearances indicated below, resulting in unpredictable airflow patterns and possible diminished performance. The unit controls will optimize operation without nuisance high-pressure safety cut-outs; however, the system designer must consider potential performance degradation. Access to the unit control center assumes the unit is no higher than on spring isolators. Recommended minimum clearances: Side to wall – 6'; rear to wall – 6'; control panel to end wall – 4'0"; top – no obstructions allowed; distance between adjacent units – 10'. No more than one adjacent wall may be higher than the unit.

Unit Dimensions (Cont'd)

YLAA0100SE

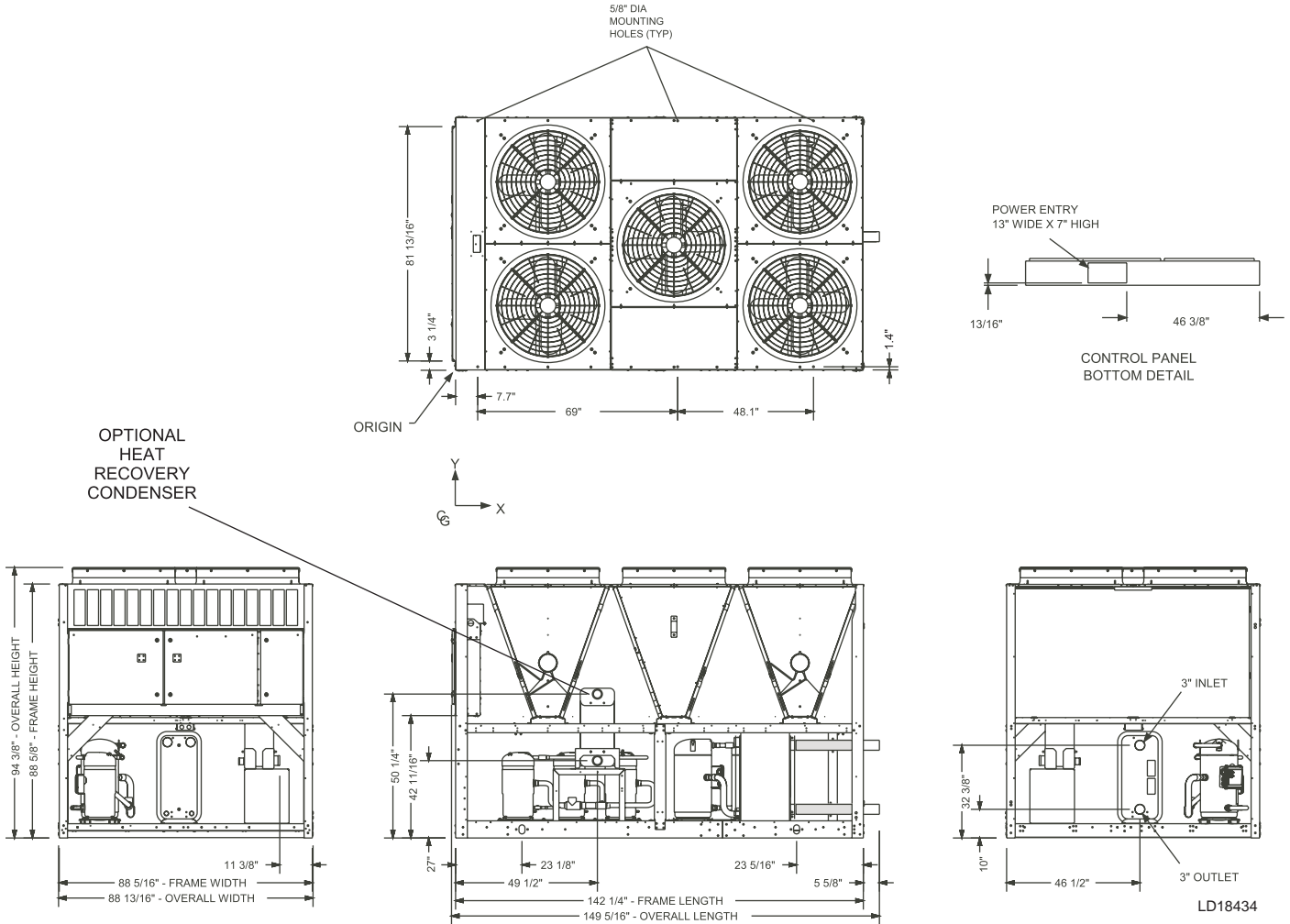

NOTE:

Placement on a level surface of free of obstructions (including snow, for winter operation) or air circulation ensures rated performance, reliable operation, and ease of maintenance. Site restrictions may compromise minimum clearances indicated below, resulting in unpredictable airflow patterns and possible diminished performance. The unit controls will optimize operation without nuisance high-pressure safety cut-outs; however, the system designer must consider potential performance degradation. Access to the unit control center assumes the unit is no higher than on spring isolators. Recommended minimum clearances: Side to wall – 6'; rear to wall – 6'; control panel to end wall – 4'0"; top – no obstructions allowed; distance between adjacent units – 10'. No more than one adjacent wall may be higher than the unit.

Unit Dimensions (Cont'd)

YLAA0120SE, YLAA0092HE, YLAA0101HE

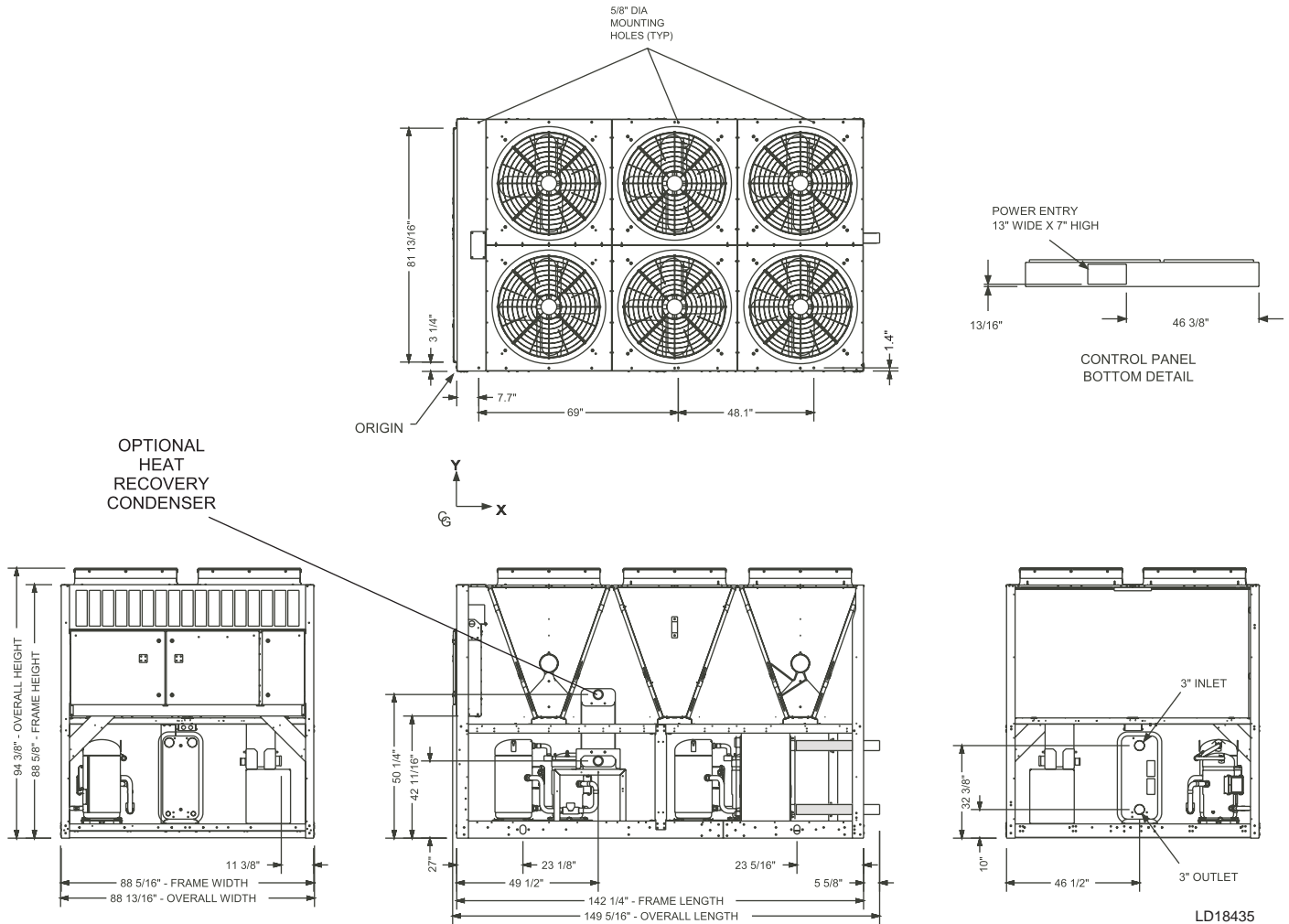

NOTE:

Placement on a level surface of free of obstructions (including snow, for winter operation) or air circulation ensures rated performance, reliable operation, and ease of maintenance. Site restrictions may compromise minimum clearances indicated below, resulting in unpredictable airflow patterns and possible diminished performance. The unit controls will optimize operation without nuisance high-pressure safety cut-outs; however, the system designer must consider potential performance degradation. Access to the unit control center assumes the unit is no higher than on spring isolators. Recommended minimum clearances: Side to wall – 6'; rear to wall – 6'; control panel to end wall – 4'0"; top – no obstructions allowed; distance between adjacent units – 10'. No more than one adjacent wall may be higher than the unit.

Unit Dimensions (Cont'd)

YLAA0125HE, YLAA 0136SE, YLAA0155SE, YLAA0142HE

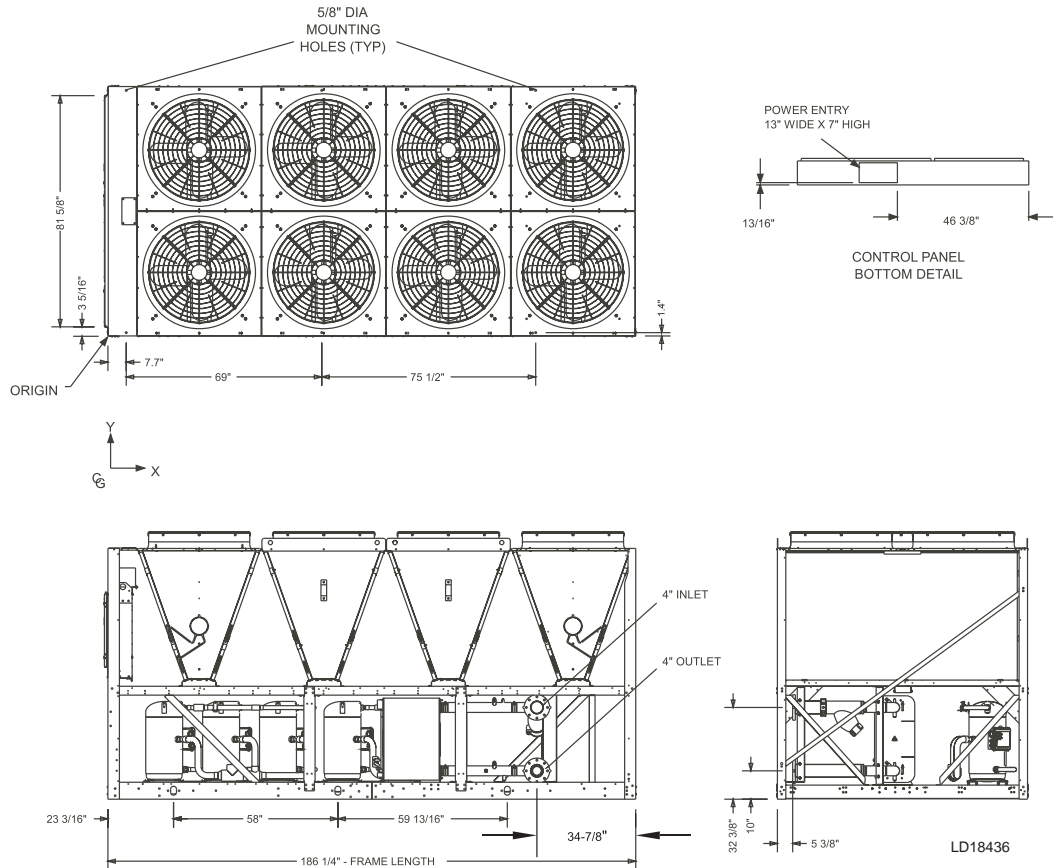

NOTE:

Placement on a level surface of free of obstructions (including snow, for winter operation) or air circulation ensures rated performance, reliable operation, and ease of maintenance. Site restrictions may compromise minimum clearances indicated below, resulting in unpredictable airflow patterns and possible diminished performance. The unit controls will optimize operation without nuisance high-pressure safety cut-outs; however, the system designer must consider potential performance degradation. Access to the unit control center assumes the unit is no higher than on spring isolators. Recommended minimum clearances: Side to wall – 6'; rear to wall – 6'; control panel to end wall – 4'0"; top – no obstructions allowed; distance between adjacent units – 10'. No more than one adjacent wall may be higher than the unit.

Unit Dimensions (Cont'd)

YLAA 0170SE, YLAA0156HE, YLAA0175HE

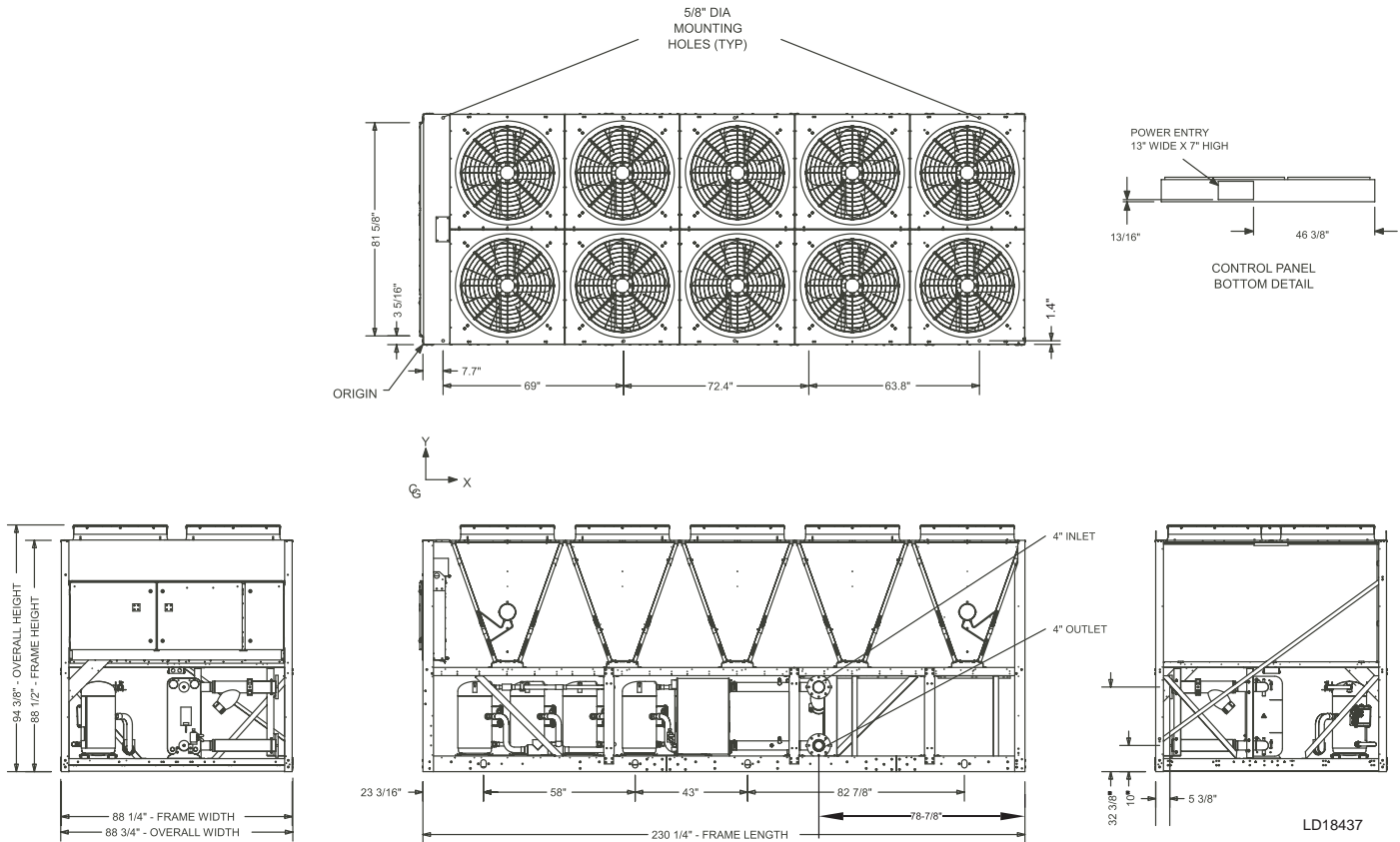

NOTE:

Placement on a level surface of free of obstructions (including snow, for winter operation) or air circulation ensures rated performance, reliable operation, and ease of maintenance. Site restrictions may compromise minimum clearances indicated below, resulting in unpredictable airflow patterns and possible diminished performance. The unit controls will optimize operation without nuisance high-pressure safety cut-outs; however, the system designer must consider potential performance degradation. Access to the unit control center assumes the unit is no higher than on spring isolators. Recommended minimum clearances: Side to wall – 6'; rear to wall – 6'; control panel to end wall – 4'0"; top – no obstructions allowed; distance between adjacent units – 10'. No more than one adjacent wall may be higher than the unit.

Isolator Locations

FOUR FAN ISOLATOR LOCATIONS YLAA0058HE, YLAA0065HE, YLAA0081HE

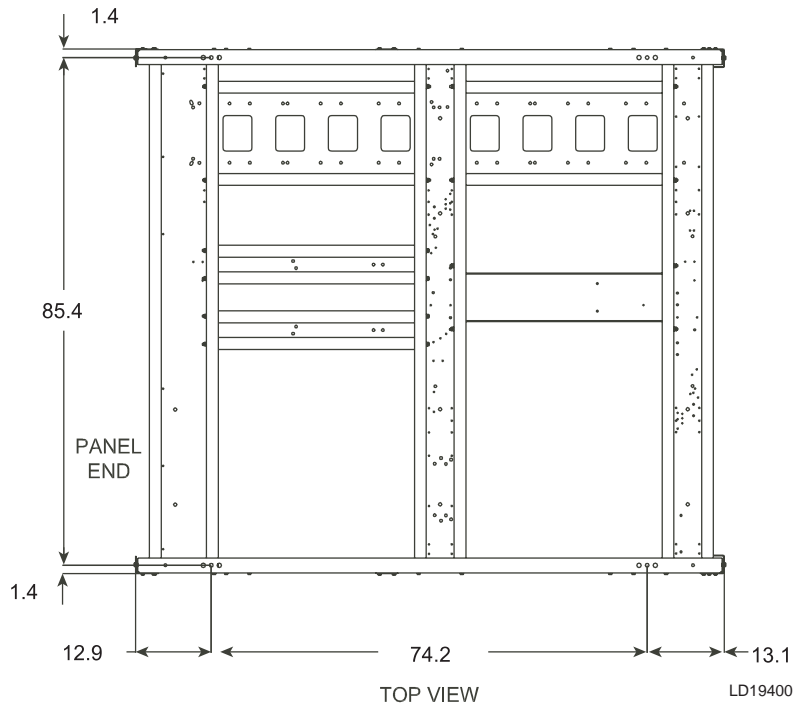

FOUR FAN ISOLATOR LOCATIONS YLAA0070SE, YLAA0080SE, YLAA0089SE

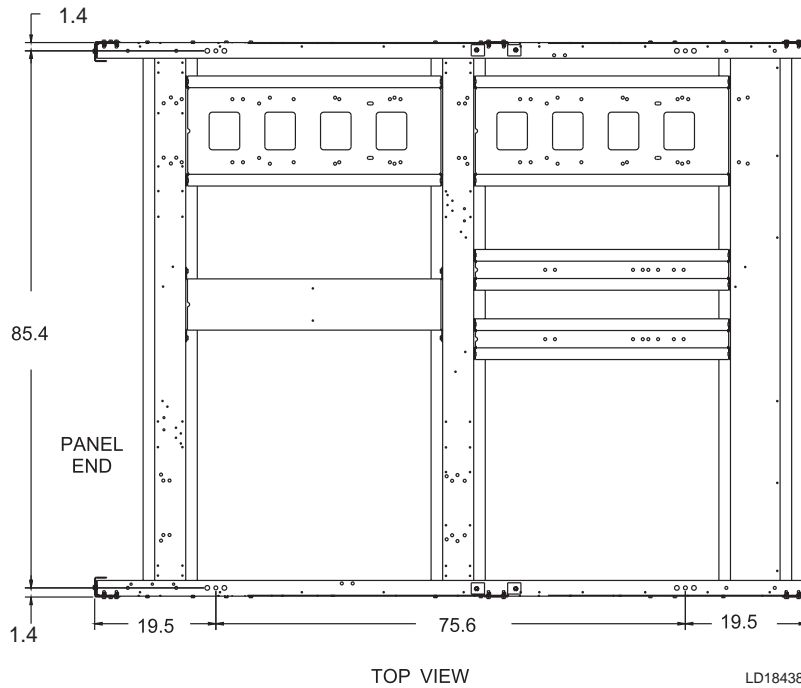

All dimensions are inches unless otherwise specified.
Dimensions indicate isolator mounting centerlines.

Isolator Locations (Cont'd)

FIVE & SIX FAN ISOLATOR LOCATIONS YLA0100SE, YLA0120SE, YLA0092HE, YLA0101HE

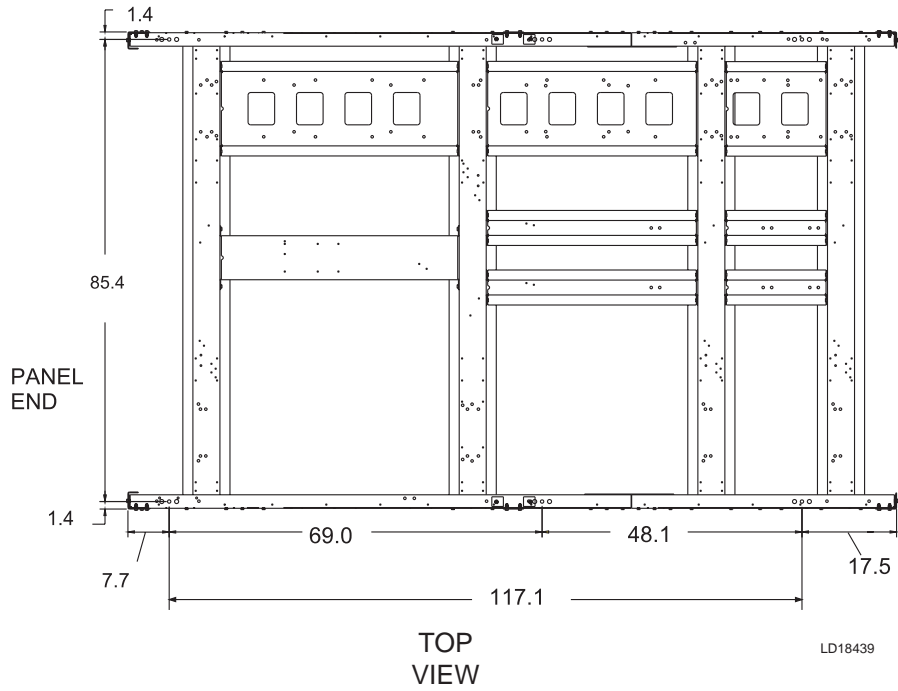

EIGHT FAN ISOLATOR LOCATIONS YLA0125HE, YLA0136SE, YLA0155SE, YLA0142HE

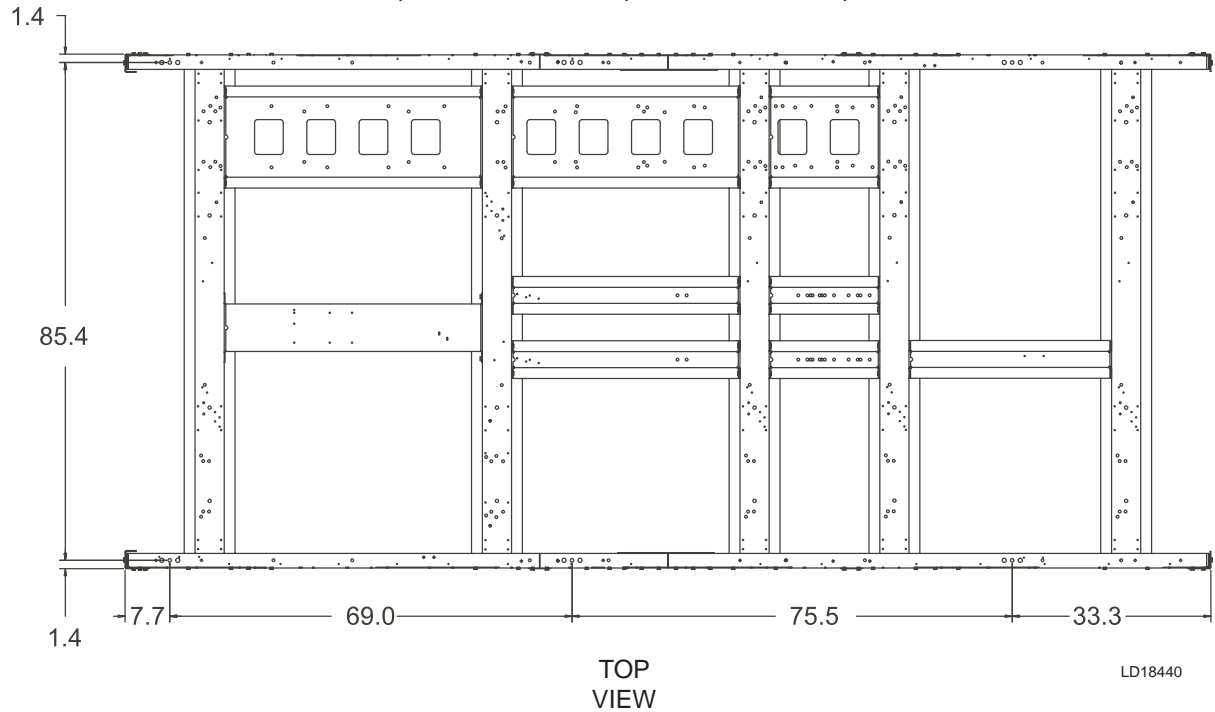

All dimensions are inches unless otherwise specified.
Dimensions indicate isolator mounting centerlines.

Isolator Locations (Cont'd)

TEN FAN ISOLATOR LOCATIONS YLAA 0170SE, YLAA0156HE, YLAA0175HE

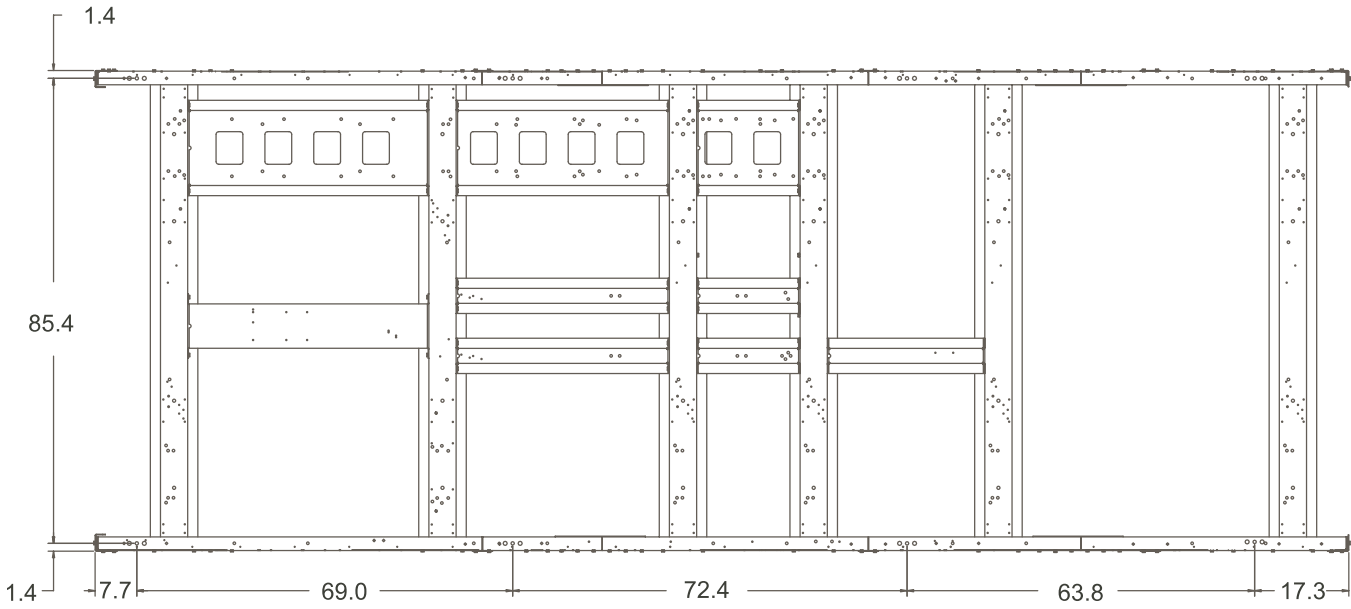

TOP
VIEW

LD18441

All dimensions are inches unless otherwise specified.
Dimensions indicate isolator mounting centerlines.

THIS PAGE INTENTIONALLY LEFT BLANK.

Isolator Details

TWO INCH DEFLECTION, SEISMIC SPRING ISOLATOR (Y2RS-)

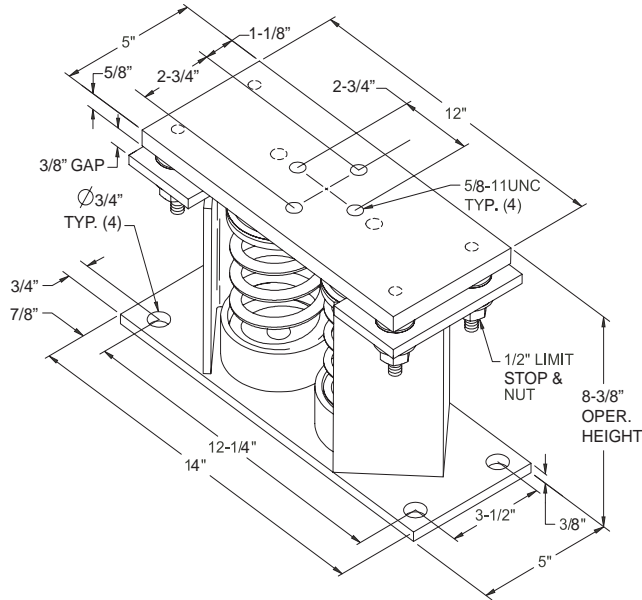

LD18442

MODEL Y2RSI-2D SEISMICALLY RESTRAINED VIBRATION ISOLATOR FOR 2" DEFLECTION						
SEISMIC MOUNT	RATED LOAD LBS (KG)	RATED DEFLECTION IN (MM)	SPRING RATE LBS/IN (N/M)	SOLID LOAD LBS (KG)	COLOR CODE	ALLOWABLE G RATING HORIZONTAL
Y2RSI-2D-150	150 (68)	2.4 (61)	62 (7)	234 (106)	WHITE	34.7
Y2RSI-2D-320	320 (145)	2.3 (58)	140 (16)	490 (222)	YELLOW	16.3
Y2RSI-2D-460	460 (209)	2.3 (58)	200 (23)	688 (312)	GREEN	11.3
Y2RSI-2D-710	710 (322)	2.2 (56)	330 (37)	1072 (486)	DK BROWN	7.3
Y2RSI-2D-870	870 (395)	1.9 (48)	460 (52)	1312 (595)	RED	6
Y2RSI-2D-1200N	1200 (544)	1.9 (48)	638 (72)	1818 (825)	RED/BLACK	4.3
Y2RSI-2D-1450	1450 (658)	1.8 (46)	900 (102)	2450 (1111)	TAN	3.6
Y2RSI-2D-1690	1690 (767)	1.7 (43)	1140 (129)	2892 (1312)	PINK	3.1
Y2RSI-2D-2000N	2000 (907)	1.7 (43)	1318 (149)	3342 (1516)	PINK/BLACK	2.6
Y2RSI-2D-2640N	2640 (1197)	1.5 (38)	1854 (209)	4283 (1943)	PINK/GRAY	2
Y2RSI-2D-2870N	3080 (1397)	1.5 (38)	2004 (226)	4629 (2100)	PINK/GRAY/ ORANGE	1.7
Y2RSI-2D-3280N	3740 (1696)	1.8 (46)	2134 (241)	4930 (2236)	PINK/GRAY/DK BROWN	1.4

Isolator Details (Cont'd)

ONE INCH DEFLECTION SPRING ISOLATOR (CPX-X-)

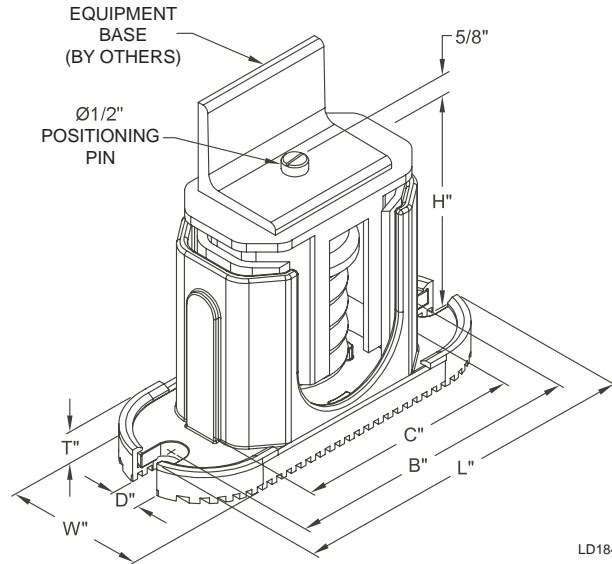

LD18443

MOUNT	DIMENSION DATA INCHES (MM)						
	W	D	L	B	C	T	H
CP1	3 (76)	0.625 (16)	7.75 (197)	6.5 (165)	4.75 (121)	0.5 (13)	4.625 (117)
CP2	3 (76)	0.625 (16)	10.5 (267)	9.25 (235)	7.75 (197)	0.5625 (14)	6 (152)

MOUNT	RATED CAPACITY LBS (KG)	DEFLECTION RATED IN (MM)	COLOR CODE
CP1-1D-85	85 (39)	1020 (463)	LT. PURPLE
CP1-1D-120	120 (54)	1.2 (30)	DK. YELLOW
CP1-1D-175	175 (79)	1.17 (30)	DK. BLUE
CP1-1D-250	250 (113)	1.4 (36)	YELLOW
CP1-1D-340	340 (154)	1.13 (29)	RED
CP1-1D-510	510 (231)	1.02 (26)	BLACK
CP1-1D-675	675 (306)	1.32 (34)	DK. PURPLE
CP1-1D-900	900 (408)	1.02 (26)	DK. GREEN
CP1-1D-1200	1200 (544)	0.9 (23)	GRAY
CP1-1D-1360	1360 (617)	0.77 (20)	WHITE
CP1-1D-1785N	1785 (810)	0.88 (22)	GRAY/RED

MOUNT	RATED CAPACITY LBS (KG)	DEFLECTION RATED IN (MM)	COLOR CODE
CP2-1D-1020	1020 (463)	1.020 (46)	BLACK
CP2-1D-1350	1350 (612)	1.32 (34)	DK. PURPLE
CP2-1D-1800	1800 (816)	1.02 (26)	DK. GREEN
CP2-1D-2400	2400 (1089)	0.9 (23)	GRAY
CP2-1D-2720	2720 (1234)	0.77 (20)	WHITE
CP2-1D-3570N	3570 (1619)	0.88 (22)	GRAY / RED

Isolator Details (Cont'd)

ELASTOMERIC ISOLATOR

RD3 ISOLATORS

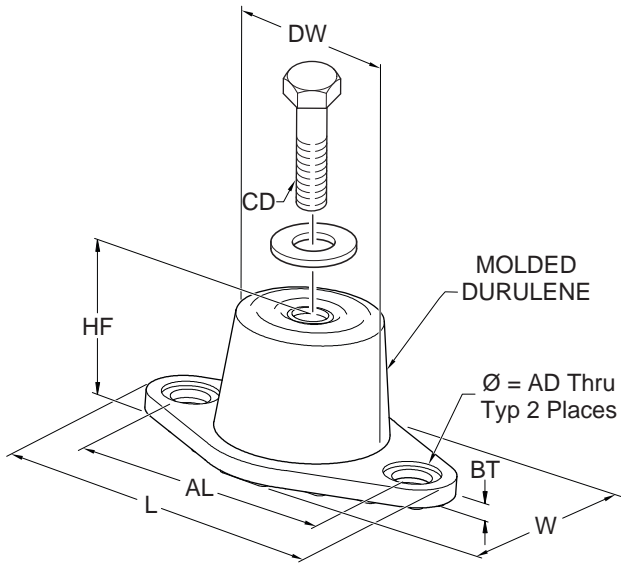

RD4 ISOLATORS

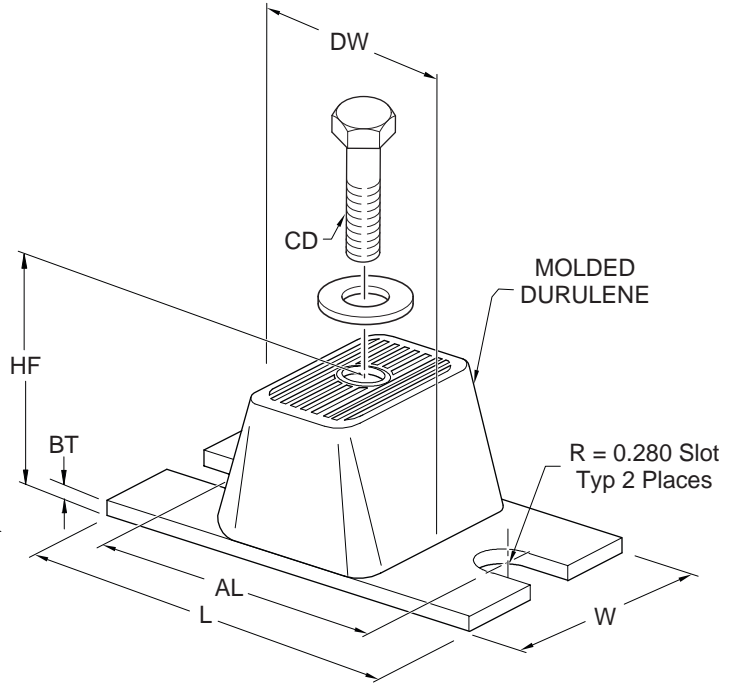

LD17304

MOUNT TYPE	DIMENSION DATA INCHES (mm)							
	L	W	HF	AL	AD	BT	CD	DW
RD3-WR	5.5 (139.7)	3.38 (85.85)	2.88 (73.15)	4.13 (104.90)	0.56 (14.22)	0.25 (6.35)	1/2-13 UNC X 1	2.5 (63.5)
RD4-WR	6.25 (158.7)	4.63 (117.60)	2.75 (69.85)	5 (127)	0.56 (14.22)	0.38 (9.65)	1/2-13 UNC X 1	3 (76.2)

RD3	RATED CAPACITY LBS (KG)	RATED DEFLECTION IN (MM)	DURO (± 5)
RD3-BROWN-WR	250 (113)	0.5 (12)	40
RD3-BRICK RED-WR	525 (238)	0.5 (12)	50
RD3-LIME-WR	750 (340)	0.5 (12)	60
RD3-CHARCOAL-WR	1100 (499)	0.5 (12)	70

RD4	RATED CAPACITY LBS (KG)	RATED DEFLECTION IN (MM)	DURO (± 5)
RD4-BROWN-WR	1500 (680)	0.5 (12)	40
RD4-BRICK RED-WR	2250 (1021)	0.5 (12)	50
RD4-LIME-WR	3000 (1361)	0.5 (12)	60
RD4-CHARCOAL-WR	4000 (1814)	0.5 (12)	70

Electrical Notes

NOTES:

1. Minimum Circuit Ampacity (MCA) is based on 125% of the rated load amps for the largest motor plus 100% of the rated load amps for all other loads included in the circuit, per N.E.C. Article 430-24. If the optional Factory Mounted Control Transformer is provided, add the following MCA values to the electrical tables for the system providing power to the transformer: -17, add 2.5 amps; -28, add 2.3 amps; -40, add 1.5 amps; -46, add 1.3 amps; -58, add 1 amp.
2. The minimum recommended disconnect switch is based on 115% of the rated load amps for all loads included in the circuit, per N.E.C. Article 440.
3. Minimum fuse size is based upon 150% of the rated load amps for the largest motor plus 100% of the rated load amps for all other loads included in the circuit to avoid nuisance trips at start-up due to lock rotor amps. It is not recommended in applications where brown outs, frequent starting and stopping of the unit, and/or operation at ambient temperatures in excess of 95°F (35°C) is anticipated.
4. Maximum fuse size is based upon 225% of the rated load amps for the largest motor plus 100% of the rated load amps for all other loads included in the circuit, per N.E.C. Article 440-22.
5. Circuit breakers must be UL listed and CSA certified and maximum size is based on 225% of the rated load amps for the largest motor plus 100% of the rated load amps for all other loads included in the circuit. Otherwise, HACR-type circuit breakers must be used. Maximum HACR circuit breaker rating is based on 225% of the rated load amps for the largest motor plus 100% of the rated load amps for all other loads included in the circuit.
6. The "INCOMING WIRE RANGE" is the minimum and maximum wire size that can be accommodated by the unit wiring lugs. The (2) preceding the wire range indicates the number of termination points available per phase of the wire range specified. Actual wire size and number of wires per phase must be determined based on the National Electrical Code, using copper connectors only. Field wiring must also comply with local codes.
7. A ground lug is provided for each compressor system to accommodate a field grounding conductor per N.E.C. Table 250-95. A control circuit grounding lug is also supplied.
8. The supplied disconnect is a "Disconnecting Means" as defined in the N.E.C. 100, and is intended for isolating the unit for the available power supply to perform maintenance and troubleshooting. This disconnect is not intended to be a Load Break Device.
9. Field Wiring by others which complies to the National Electrical Code & Local Codes.

Electrical Notes (Cont'd)**LEGEND**

ACR-LINE	ACROSS THE LINE START
C.B.	CIRCUIT BREAKER
D.E.	DUAL ELEMENT FUSE
DISC SW	DISCONNECT SWITCH
FACT MOUNT CB	FACTORY MOUNTED CIRCUIT BREAKER
FLA	FULL LOAD AMPS
HZ	HERTZ
MAX	MAXIMUM
MCA	MINIMUM CIRCUIT AMPACITY
MIN	MINIMUM
MIN NF	MINIMUM NON FUSED
RLA	RATED LOAD AMPS
S.P. WIRE	SINGLE POINT WIRING
UNIT MTD SERV SW	UNIT MOUNTED SERVICE (NON-FUSED DISCONNECT SWITCH)
LRA	LOCKED ROTOR AMPS

VOLTAGE CODE

- 17 = 208-3-60
- 28 = 230-3-60
- 40 = 380-3-60
- 46 = 460-3-60
- 58 = 575-3-60

Variable Speed Pump Electrical Data

PUMP	HORSE POWER	RPM	PUMP ELECTRICAL DATA									
			208V-3-60HZ		230V-3-60HZ		380V-3-60HZ		460V-3-60HZ		575V-3-60HZ	
			FLA	LRA	FLA	LRA	FLA	LRA	FLA	LRA	FLA	LRA
A	5	3600	15.4	4.6	13	3.9	7.9	2.4	6.5	2	5.2	1.6
B	7.5	3600	23.2	7	18.4	5.5	11.1	3.3	9.2	2.8	7.4	2.2
C	10	3600	28.3	8.5	24	7.2	15.1	4.5	12	3.6	9.6	2.9
D	3	1800	9.5	2.9	8	2.4	4.7	1.4	4	1.2	3.2	1
E	15	3600	43	12.9	36.4	10.9	22	6.6	18.2	5.5	14.6	4.4
F	7.5	3600	23.2	7	18.4	5.5	11.1	3.3	9.2	2.8	7.4	2.2
G	10	3600	28.3	8.5	24	7.2	15.1	4.5	12	3.6	9.6	2.9
H	15	3600	43	12.9	36.4	10.9	22	6.6	18.2	5.5	14.6	4.4
I	5	1800	15.4	4.6	13	3.9	7.9	2.4	6.5	2	5.2	1.6
J	15	3600	43	12.9	36.4	10.9	22	6.6	18.2	5.5	14.6	4.4
K	20	3600	54	16.2	45	13.5	28.7	8.6	22.5	6.8	18	5.4
L	3	1800	9.5	2.9	8	2.4	4.7	1.4	4	1.2	3.2	1
M	10	3600	23.2	7	18.4	5.5	11.1	3.3	9.2	2.8	7.4	2.2
N	20	3600	54	16.2	45	13.5	28.7	8.6	22.5	6.8	18	5.4
P	5	1800	15.4	4.6	13	3.9	7.9	2.4	6.5	2	5.2	1.6
R	15	3600	43	12.9	36.4	10.9	22	6.6	18.2	5.5	14.6	4.4
S	3	3600	9.5	2.9	8	2.4	4.7	1.4	4	1.2	3.2	1
T	5	3600	15.4	4.6	13	3.9	7.9	2.4	6.5	2	5.2	1.6
U	10	3600	28.3	8.5	24	7.2	15.1	4.5	12	3.6	9.6	2.9
V	10	1800	28.3	8.5	24	7.2	15.1	4.5	12	3.6	9.6	2.9

CONTROL TRANSFORMER LOAD		
VOLT	KVA	
	2	3
208	9.6	14.4
230	8.7	13.0
380	5.3	7.9
460	4.3	6.5
575	3.5	5.2

Wiring Lugs

YLAA	GLOBAL MARKET		SINGLE POINT SUPPLY TERMINAL BLOCK	MOLDED CASE SWITCH SINGLE POINT SUPPLY		MOLDED CASE CIRCUIT BREAKER SINGLE POINT SUPPLY	
	VOLTS	HZ	INSTALLED LUG	INSTALLED LUG	ALTERNATE LUG	INSTALLED LUG	ALTERNATE LUG
0058	208	60	(1) # 6 - 500	(2) 250 - 500	(3) 2/0 - 400	(2) 3/0 - 250	(1) 250 - 500
	230	60	(1) # 6 - 500	(2) 250 - 500	(3) 2/0 - 400	(2) 3/0 - 250	(1) 250 - 500
	380	60	(1) # 6 - 500	(1) 6 - 350	-	(1) 6 - 350	-
	460	60	(1) # 6 - 500	(1) 6 - 350	-	(1) 6 - 350	-
	575	60	(1) # 6 - 500	(1) 6 - 350	-	(1) 6 - 350	-
0065	208	60	(2) # 6 - 500	(2) 250 - 500	(3) 2/0 - 400	(2) 3/0 - 250	(1) 250 - 500
	230	60	(2) # 6 - 500	(2) 250 - 500	(3) 2/0 - 400	(2) 3/0 - 250	(1) 250 - 500
	380	60	(1) # 6 - 500	(1) 250 - 500	(2) 3/0 - 250	(1) 6 - 350	-
	460	60	(1) # 6 - 500	(1) 6 - 350	-	(1) 6 - 350	-
	575	60	(1) # 6 - 500	(1) 6 - 350	-	(1) 6 - 350	-
0070	208	60	(2) # 6 - 500	(2) 250 - 500	(3) 2/0 - 400	(2) 3/0 - 250	(1) 250 - 500
	230	60	(2) # 6 - 500	(2) 250 - 500	(3) 2/0 - 400	(2) 3/0 - 250	(1) 250 - 500
	380	60	(1) # 6 - 500	(1) 6 - 350	-	(1) 6 - 350	-
	460	60	(1) # 6 - 500	(1) 6 - 350	-	(1) 6 - 350	-
	575	60	(1) # 6 - 500	(1) 6 - 350	-	(1) 6 - 350	-
0080	208	60	(2) # 6 - 500	(2) 250 - 500	(3) 2/0 - 400	(2) 3/0 - 250	(1) 250 - 500
	230	60	(2) # 6 - 500	(2) 250 - 500	(3) 2/0 - 400	(2) 3/0 - 250	(1) 250 - 500
	380	60	(1) # 6 - 500	(2) 3/0 - 250	(1) 250 - 500	(1) 6 - 350	-
	460	60	(1) # 6 - 500	(1) 6 - 350	-	(1) 6 - 350	-
	575	60	(1) # 6 - 500	(1) 6 - 350	-	(1) 6 - 350	-
0081	208	60	(2) # 6 - 500	(2) 250 - 500	(3) 2/0 - 400	(3) 2/0 - 400	(2) 250 - 500
	230	60	(2) # 6 - 500	(2) 250 - 500	(3) 2/0 - 400	(3) 2/0 - 400	(2) 250 - 500
	380	60	(1) # 6 - 500	(1) 250 - 500	(2) 3/0 - 250	(2) 3/0 - 250	(1) 250 - 500
	460	60	(1) # 6 - 500	(1) 250 - 500	(2) 3/0 - 250	(1) 6 - 350	-
	575	60	(1) # 6 - 500	(1) 6 - 350	-	(1) 6 - 350	-
0089	208	60	(2) # 6 - 500	(2) 250 - 500	(3) 2/0 - 400	(2) 250 - 500	(3) 2/0 - 400
	230	60	(2) # 6 - 500	(2) 250 - 500	(3) 2/0 - 400	(2) 250 - 500	(3) 2/0 - 400
	380	60	(1) # 6 - 500	(2) 3/0 - 250	(1) 250 - 500	(2) 3/0 - 250	(1) 250 - 500
	460	60	(1) # 6 - 500	(1) 250 - 500	(2) 3/0 - 250	(1) 6 - 350	-
	575	60	(1) # 6 - 500	(1) 6 - 350	-	(1) 6 - 350	-
0092	208	60	(2) # 6 - 500	(2) 250 - 500	(3) 2/0 - 400	(2) 250 - 500	(3) 2/0 - 400
	230	60	(2) # 6 - 500	(2) 250 - 500	(3) 2/0 - 400	(2) 250 - 500	(3) 2/0 - 400
	380	60	(1) # 6 - 500	(2) 3/0 - 250	(1) 250 - 500	(2) 3/0 - 250	(1) 250 - 500
	460	60	(1) # 6 - 500	(1) 250 - 500	(2) 3/0 - 250	(1) 6 - 350	-
	575	60	(1) # 6 - 500	(1) 6 - 350	-	(1) 6 - 350	-

NOTE: Alternate lugs are provided in the panel for field electricians and contractors, should there be a need for other lug arrangements that the installed lugs on the non-fused disconnect switch and circuit breaker panels.

Wiring Lugs (Cont'd)

YLAA	GLOBAL MARKET		SINGLE POINT SUPPLY TERMINAL BLOCK	MOLDED CASE SWITCH SINGLE POINT SUPPLY		MOLDED CASE CIRCUIT BREAKER SINGLE POINT SUPPLY	
	VOLTS	HZ	INSTALLED LUG	INSTALLED LUG	ALTERNATE LUG	INSTALLED LUG	ALTERNATE LUG
0100/0101	208	60	(2) # 6 - 500	(2) 250 - 500	(3) 2/0 - 400	(2) 250 - 500	(3) 2/0 - 400
	230	60	(2) # 6 - 500	(2) 250 - 500	(3) 2/0 - 400	(2) 250 - 500	(3) 2/0 - 400
	380	60	(1) # 6 - 500	(2) 3/0 - 250	(1) 250 - 500	(2) 3/0 - 250	(1) 250 - 500
	460	60	(1) # 6 - 500	(2) 3/0 - 250	(1) 250 - 500	(2) 3/0 - 250	(1) 250 - 500
	575	60	(1) # 6 - 500	(1) 6 - 350	-	(1) 6 - 350	-
0120/0130/0125	208	60	(2) # 6 - 500	(3) 2/0 - 400	(2) 250 - 500	(3) 2/0 - 400	(2) 250 - 500
	230	60	(2) # 6 - 500	(3) 2/0 - 400	(2) 250 - 500	(3) 2/0 - 400	(2) 250 - 500
	380	60	(1) # 6 - 500	(2) 3/0 - 250	(1) 250 - 500	(2) 3/0 - 250	(1) 250 - 500
	400/460	60	(1) # 6 - 500	(2) 3/0 - 250	(1) 250 - 500	(2) 3/0 - 250	(1) 250 - 500
	575	60	(1) # 6 - 500	(2) 3/0 - 250	(1) 250 - 500	(2) 3/0 - 250	(1) 250 - 500
0135/0141	208	60	(2) # 6 - 500	(3) 2/0 - 400	(2) 250 - 500	(3) 2/0 - 400	(2) 250 - 500
	230	60	(2) # 6 - 500	(3) 2/0 - 400	(2) 250 - 500	(3) 2/0 - 400	(2) 250 - 500
	380	60	(1) # 6 - 500	(2) 250 - 500	(3) 2/0 - 400	(2) 3/0 - 250	(1) 250 - 500
	400/460	60	(1) # 6 - 500	(1) 250 - 500	(2) 3/0 - 250	(1) 250 - 500	(2) 3/0 - 250
	575	60	(1) # 6 - 500	(1) 250 - 500	(2) 3/0 - 250	(1) 250 - 500	(2) 3/0 - 250
0136/0142	208	60	(2) # 6 - 500	(2) 250 - 500	(3) 2/0 - 400	(2) 250 - 500	(3) 2/0 - 400
	230	60					
	380	60	(2) # 6 - 500	(3) 2/0 - 400	(2) 250 - 500	(2) 3/0 - 250	(1) 250 - 500
	400/460	60	(1) # 6 - 500	(1) 250 - 500	(2) 3/0 - 250	(1) 250 - 500	(2) 3/0 - 250
	575	60	(1) # 6 - 500	(1) 250 - 500	(2) 3/0 - 250	(1) 250 - 500	(2) 3/0 - 250
0150/0155/0158/0156	208	60	(3) 2/0 - 400	(3) 2/0 - 400	(2) 250 - 500	(3) 2/0 - 400	(2) 250 - 500
	230	60	(3) 2/0 - 400	(3) 2/0 - 400	(2) 250 - 500	(3) 2/0 - 400	(2) 250 - 500
	380	60	(2) # 6 - 500	(2) 250 - 500	(3) 2/0 - 400	(2) 250 - 500	(3) 2/0 - 400
	400/460	60	(2) # 6 - 500	(1) 250 - 500	(2) 3/0 - 250	(1) 250 - 500	(2) 3/0 - 250
	575	60	(1) # 6 - 500	(2) 3/0 - 250	(1) 250 - 500	(2) 3/0 - 250	(1) 250 - 500
0170/0175	208	60	(4) 4/0 - 500	(4) 4/0 - 500	-	(3) 2/0 - 400	(2) 250 - 500
	230	60	(4) 4/0 - 500	(4) 4/0 - 500	-	(3) 2/0 - 400	(2) 250 - 500
	380	60	(2) # 6 - 500	(2) 250 - 500	(3) 2/0 - 400	(2) 250 - 500	(3) 2/0 - 400
	460	60	(2) # 6 - 500	(2) 250 - 500	(3) 2/0 - 400	(2) 3/0 - 250	(1) 250 - 500
	575	60	(1) # 6 - 500	(2) 3/0 - 250	(1) 250 - 500	(2) 3/0 - 250	(1) 250 - 500

NOTE: Alternate lugs are provided in the panel for field electricians and contractors, should there be a need for other lug arrangements than the installed lugs on the non-fused disconnect switch and circuit breaker panels.

Electrical Data Without Pumps

YLAA	VOLT	HZ	MCA	MIN N/F DISC SW	MIN DUAL ELEM FUSE & CB	MAX DUAL ELEM CB	SYSTEM # 1								
							COMPR 1		COMPR 2		COMPR 3		STD FLOW FANS		
							RLA	LRA	RLA	LRA	RLA	LRA	QTY	FLA	LRA
58	208	60	276	400	300	300	57.7	284	57.7	284			2	7.6	44
	230	60	275	400	300	300	57.7	330	57.7	330			2	7.4	37
	380	60	149	200	175	175	30.9	192	30.9	192			2	4.5	23.1
	460	60	130	200	150	150	26.9	180	26.9	180			2	4	19
	575	60	103	150	110	110	21.5	132	21.5	132			2	2.9	15.3
65	208	60	306	400	350	350	48.5	249	48.5	249	48.5	249	2	7.6	44
	230	60	305	400	350	350	48.5	288	48.5	288	48.5	288	2	7.4	37
	380	60	170	250	200	200	27.6	159	27.6	159	27.6	159	2	4.5	23.1
	460	60	150	200	175	175	24.4	145	24.4	145	24.4	145	2	4	19
	575	60	112	150	125	125	17.4	109	17.4	109	17.4	109	2	2.9	15.3
70	208	60	334	400	350	350	48.5	249	48.5	249	48.5	249	2	7.6	44
	230	60	333	400	350	350	48.5	249	48.5	249	48.5	249	2	7.4	37
	380	60	191	250	225	225	27.6	159	27.6	159	27.6	159	2	4.5	23.1
	460	60	169	200	175	175	24.4	145	24.4	145	24.4	145	2	4	19
	575	60	120	150	125	125	17.4	109	17.4	109	17.4	109	2	2.9	15.3
80	208	60	363	600	400	400	57.7	284	57.7	284	57.7	284	2	7.6	44
	230	60	363	600	400	400	57.7	330	57.7	330	57.7	330	2	7.4	37
	380	60	201	250	225	225	30.9	192	30.9	192	30.9	192	2	4.5	23.1
	460	60	177	250	200	200	26.9	180	26.9	180	26.9	180	2	4	19
	575	60	134	200	150	150	21.5	132	21.5	132	21.5	132	2	2.9	15.3
81	208	60	363	400	400	400	57.7	284	57.7	284	57.7	284	2	7.6	44
	230	60	363	400	400	400	57.7	330	57.7	330	57.7	330	2	7.4	37
	380	60	201	250	225	225	30.9	192	30.9	192	30.9	192	2	4.5	23.1
	460	60	177	250	200	200	26.9	180	26.9	180	26.9	180	2	4	19
	575	60	134	200	150	150	21.5	132	21.5	132	21.5	132	2	2.9	15.3
89	208	60	391	600	450	450	57.7	284	57.7	284	57.7	284	2	7.6	44
	230	60	390	600	450	450	57.7	330	57.7	330	57.7	330	2	7.4	37
	380	60	211	250	250	250	30.9	192	30.9	192	30.9	192	2	4.5	23.1
	460	60	184	250	200	200	26.9	180	26.9	180	26.9	180	2	4	19
	575	60	146	200	150	150	21.5	132	21.5	132	21.5	132	2	2.9	15.3
92	208	60	406	600	450	450	57.7	284	57.7	284	57.7	284	3	7.6	44
	230	60	405	600	450	450	57.7	330	57.7	330	57.7	330	3	7.4	37
	380	60	220	400	250	250	30.9	192	30.9	192	30.9	192	3	4.5	23.1
	460	60	192	250	225	225	26.9	180	26.9	180	26.9	180	3	4	19
	575	60	152	200	150	150	21.5	132	21.5	132	21.5	132	3	2.9	15.3
100	208	60	450	600	500	500	57.7	284	57.7	284	57.7	284	2	7.6	44
	230	60	449	600	500	500	57.7	330	57.7	330	57.7	330	2	7.4	37
	380	60	260	400	300	300	30.9	192	30.9	192	30.9	192	2	4.5	23.1
	460	60	220	400	250	250	26.9	180	26.9	180	26.9	180	2	4	19
	575	60	175	250	200	200	21.5	132	21.5	132	21.5	132	2	2.9	15.3

NOTES:

1. Reference PIN 59 for pump models.
2. Use this table along with Pump Electrical Data on page 44 to determine electrical data of the unit plus the pump.
3. Does not include the Control Transformer on page 41)

Electrical Data Without Pumps (Cont'd)

YLAA	VOLT	HZ	MCA	MIN N/F DISC SW	MIN DUAL ELEM FUSE & CB	MAX DUAL ELEM FUSE & CB	SYSTEM # 2								
							COMPR 1		COMPR 2		COMPR 3		STD FLOW FANS		
							RLA	LRA	RLA	LRA	RLA	LRA	QTY	FLA	LRA
58	208	60	301	400	300	300	57.7	284	57.7	284			2	7.6	44
	230	60	297	400	300	300	57.7	330	57.7	330			2	7.4	37
	380	60	162	200	175	175	30.9	192	30.9	192			2	4.5	23.1
	460	60	141	200	150	150	26.9	180	26.9	180			2	4	19
	575	60	106	150	110	110	21.5	132	21.5	132			2	2.9	15.3
65	208	60	331	400	350	350	57.7	284	57.7	249			2	7.6	44
	230	60	327	400	350	350	57.7	330	57.7	288			2	7.4	37
	380	60	183	250	200	200	30.9	192	30.9	139			2	4.5	23.1
	460	60	161	200	175	175	26.9	180	26.9	180			2	4	19
	575	60	116	150	125	125	21.5	132	21.5	132			2	2.9	15.3
70	208	60	359	400	350	350	48.5	249	48.5	249	48.5	249	2	7.6	44
	230	60	354	400	350	350	48.5	249	48.5	249	48.5	249	2	7.4	37
	380	60	204	250	225	225	27.6	159	27.6	159	27.6	159	2	4.5	23.1
	460	60	179	200	175	175	24.4	145	24.4	145	24.4	145	2	4	19
	575	60	124	150	125	125	17.4	109	17.4	109	17.4	109	2	2.9	15.3
80	208	60	388	600	400	400	48.5	249	48.5	249	48.5	249	2	7.6	44
	230	60	384	600	400	400	48.5	288	48.5	288	48.5	288	2	7.4	37
	380	60	214	250	225	225	27.6	159	27.6	159	27.6	159	2	4.5	23.1
	460	60	187	200	200	200	24.4	145	24.4	145	24.4	145	2	4	19
	575	60	137	150	150	150	17.4	109	17.4	109	17.4	109	2	2.9	15.3
81	208	60	388	400	400	400	48.5	249	48.5	249	48.5	249	2	7.6	44
	230	60	384	400	400	400	48.5	288	48.5	288	48.5	288	2	7.4	37
	380	60	214	250	225	225	27.6	159	27.6	159	27.6	159	2	4.5	23.1
	460	60	187	200	200	200	24.4	145	24.4	145	24.4	145	2	4	19
	575	60	137	150	150	150	17.4	109	17.4	109	17.4	109	2	2.9	15.3
89	208	60	416	600	450	450	57.7	284	57.7	284	57.7	284	2	7.6	44
	230	60	412	600	450	450	57.7	330	57.7	330	57.7	330	2	7.4	37
	380	60	224	250	250	250	30.9	192	30.9	192	30.9	192	2	4.5	23.1
	460	60	195	200	200	200	26.9	180	26.9	180	26.9	180	2	4	19
	575	60	149	150	150	150	21.5	132	21.5	132	21.5	132	2	2.9	15.3
92	208	60	431	600	450	450	57.7	284	57.7	284	57.7	284	3	7.6	44
	230	60	427	600	450	450	57.7	330	57.7	330	57.7	330	3	7.4	37
	380	60	233	250	250	250	30.9	192	30.9	192	30.9	192	3	4.5	23.1
	460	60	203	250	225	225	26.9	180	26.9	180	26.9	180	3	4	19
	575	60	155	200	150	150	21.5	132	21.5	132	21.5	132	3	2.9	15.3
100	208	60	475	600	500	500	106.2	523	106.2	523			3	7.6	44
	230	60	471	600	500	500	106.2	578	106.2	578			3	7.4	37
	380	60	273	400	300	300	64.3	355	64.3	355			3	4.5	23.1
	460	60	231	250	250	250	53.1	290	53.1	290			3	4	19
	575	60	178	200	200	200	42.5	255	42.5	255			3	2.9	15.3

NOTES:

1. Reference PIN 59 for pump models.
2. Use this table along with Pump Electrical Data on page 45 to determine electrical data of the unit plus the pump.
3. Does not include the Control Transformer on page 41)

Electrical Data Without Pumps (Cont'd)

YLAA	VOLT	HZ	MCA	MIN N/F DISC SW	MIN DUAL ELEM FUSE & CB	MAX DUAL ELEM CB	SYSTEM # 1								
							COMPR 1		COMPR 2		COMPR 3		STD FLOW FANS		
							RLA	LRA	RLA	LRA	RLA	LRA	QTY	FLA	LRA
101	208	60	458	600	500	500	57.7	284	57.7	284	57.7	284	2	7.6	44
	230	60	456	600	500	500	57.7	330	57.7	330	57.7	330	2	7.4	37
	380	60	264	400	300	300	30.9	192	30.9	192	30.9	192	2	4.5	23.1
	460	60	224	400	250	250	26.9	180	26.9	180	26.9	180	2	4	19
	575	60	178	250	200	200	21.5	132	21.5	132	21.5	132	2	2.9	15.3
120	208	60	497	800	600	600	106.2	523	106.2	523			3	7.6	44
	230	60	496	800	600	600	106.2	578	106.2	578			3	7.4	37
	380	60	300	400	350	350	64.3	355	64.3	355			3	4.5	23.1
	460	60	250	400	300	300	53.1	290	53.1	290			3	4	19
	575	60	198	250	225	225	42.5	255	42.5	255			3	2.9	15.3
125	208	60	512	800	600	600	106.2	523	106.2	523			4	7.6	44
	230	60	511	800	600	600	106.2	578	106.2	578			4	7.4	37
	380	60	309	400	350	350	64.3	355	64.3	355			4	4.5	23.1
	460	60	258	400	300	300	53.1	290	53.1	290			4	4	19
	575	60	204	250	225	225	42.5	255	42.5	255			4	2.9	15.3
136	208	60	579	800	600	600	106.2	523	106.2	523	106.2	523	4	7.6	44
	230	60	577	800	600	600	106.2	578	106.2	578	106.2	578	4	7.4	37
	380	60	338	600	400	400	64.3	355	64.3	355	64.3	355	4	4.5	23.1
	460	60	285	400	300	300	53.1	290	53.1	290	53.1	290	4	4	19
	575	60	226	400	250	250	42.5	255	42.5	255	42.5	255	4	2.9	15.3
142	208	60	579	800	600	600	106.2	523	106.2	523	106.2	523	5	7.6	44
	230	60	577	800	600	600	106.2	578	106.2	578	106.2	578	5	7.4	37
	380	60	338	600	400	400	64.3	355	64.3	355	64.3	355	5	4.5	23.1
	460	60	285	400	300	300	53.1	290	53.1	290	53.1	290	5	4	19
	575	60	226	400	250	250	42.5	255	42.5	255	42.5	255	5	2.9	15.3
155	208	60	618	800	700	700	106.2	523	106.2	523	106.2	523	4	7.6	44
	230	60	617	800	700	700	106.2	578	106.2	578	106.2	578	4	7.4	37
	380	60	374	600	400	400	64.3	355	64.3	355	64.3	355	4	4.5	23.1
	460	60	311	400	350	350	53.1	290	53.1	290	53.1	290	4	4	19
	575	60	246	400	300	300	42.5	255	42.5	255	42.5	255	4	2.9	15.3
156	208	60	634	800	700	700	106.2	523	106.2	523	106.2	523	6	7.6	44
	230	60	632	800	700	700	106.2	578	106.2	578	106.2	578	6	7.4	37
	380	60	383	600	400	400	64.3	355	64.3	355	64.3	355	6	4.5	23.1
	460	60	319	400	350	350	53.1	290	53.1	290	53.1	290	6	4	19
	575	60	252	400	300	300	42.5	255	42.5	255	42.5	255	6	2.9	15.3
170	208	60	740	1000	800	800	106.2	523	106.2	523	106.2	523	5	7.6	44
	230	60	738	1000	800	800	106.2	578	106.2	578	106.2	578	5	7.4	37
	380	60	447	600	500	500	64.3	355	64.3	355	64.3	355	5	4.5	23.1
	460	60	372	600	400	400	53.1	290	53.1	290	53.1	290	5	4	19
	575	60	295	400	350	350	42.5	255	42.5	255	42.5	255	5	2.9	15.3
175	208	60	740	1000	800	800	106.2	523	106.2	523	106.2	523	5	7.6	44
	230	60	738	1000	800	800	106.2	578	106.2	578	106.2	578	5	7.4	37
	380	60	447	600	500	500	64.3	355	64.3	355	64.3	355	5	4.5	23.1
	460	60	372	600	400	400	53.1	290	53.1	290	53.1	290	5	4	19
	575	60	295	400	350	350	42.5	255	42.5	255	42.5	255	5	2.9	15.3

NOTES:

1. Reference PIN 59 for pump models.
2. Use this table along with Pump Electrical Data on page 46 to determine electrical data of the unit plus the pump.
3. Does not include the Control Transformer. on page 41)

Electrical Data Without Pumps (Cont'd)

YLAA	VOLT	HZ	MCA	MIN N/F DISC SW	MIN DUAL ELEM FUSE & CB	MAX DUAL ELEM FUSE & CB	SYSTEM # 2								
							COMPR 1		COMPR 2		COMPR 3		STD FLOW FANS		
							RLA	LRA	RLA	LRA	RLA	LRA	QTY	FLA	LRA
101	208	60	483	600	500	500	106.2	523	106.2	523			4	7.6	44
	230	60	478	600	500	500	106.2	578	106.2	578			4	7.4	37
	380	60	278	400	300	300	64.3	355	64.3	355			4	4.5	23.1
	460	60	235	250	250	250	53.1	290	53.1	290			4	4	19
	575	60	181	200	200	200	42.5	255	42.5	255			4	2.9	15.3
120	208	60	522	600	600	600	106.2	523	106.2	523			3	7.6	44
	230	60	517	600	600	600	106.2	578	106.2	578			3	7.4	37
	380	60	313	400	350	350	64.3	355	64.3	355			3	4.5	23.1
	460	60	261	400	300	300	53.1	290	53.1	290			3	4	19
	575	60	202	250	225	225	42.5	255	42.5	255			3	2.9	15.3
125	208	60	537	600	600	600	106.2	523	106.2	523			4	7.6	44
	230	60	532	600	600	600	106.2	578	106.2	578			4	7.4	37
	380	60	322	400	350	350	64.3	355	64.3	355			4	4.5	23.1
	460	60	269	400	300	300	53.1	290	53.1	290			4	4	19
	575	60	204	250	225	225	42.5	255	42.5	255			4	2.9	15.3
136	208	60	579	800	600	600	57.7	284	57.7	284	57.7	284	4	7.6	44
	230	60	577	800	600	600	57.7	330	57.7	330	57.7	330	4	7.4	37
	380	60	338	400	400	400	30.9	192	30.9	192	30.9	192	4	4.5	23.1
	460	60	285	400	300	300	26.9	180	26.9	180	26.9	180	4	4	19
	575	60	226	250	250	250	21.5	132	21.5	132	21.5	132	4	2.9	15.3
142	208	60	579	800	600	600	57.7	284	57.7	284	57.7	284	3	7.6	44
	230	60	577	800	600	600	57.7	330	57.7	330	57.7	330	3	7.4	37
	380	60	338	400	400	400	30.9	192	30.9	192	30.9	192	3	4.5	23.1
	460	60	285	400	300	300	26.9	180	26.9	180	26.9	180	3	4	19
	575	60	226	250	250	250	21.5	132	21.5	132	21.5	132	3	2.9	15.3
155	208	60	618	800	700	700	106.2	523	106.2	523			4	7.6	44
	230	60	617	800	700	700	106.2	578	106.2	578			4	7.4	37
	380	60	374	400	400	400	64.3	355	64.3	355			4	4.5	23.1
	460	60	311	400	350	350	53.1	290	53.1	290			4	4	19
	575	60	246	400	300	300	42.5	255	42.5	255			4	2.9	15.3
156	208	60	634	800	700	700	106.2	523	106.2	523			4	7.6	44
	230	60	632	800	700	700	106.2	578	106.2	578			4	7.4	37
	380	60	383	400	400	400	64.3	355	64.3	355			4	4.5	23.1
	460	60	319	400	350	350	53.1	290	53.1	290			4	4	19
	575	60	252	400	300	300	42.5	255	42.5	255			4	2.9	15.3
170	208	60	740	800	800	800	106.2	523	106.2	523	106.2	523	5	7.6	44
	230	60	738	800	800	800	106.2	578	106.2	578	106.2	578	5	7.4	37
	380	60	447	600	500	500	64.3	355	64.3	355	64.3	355	5	4.5	23.1
	460	60	372	400	400	400	53.1	290	53.1	290	53.1	290	5	4	19
	575	60	295	400	350	350	42.5	255	42.5	255	42.5	255	5	2.9	15.3
175	208	60	740	800	800	800	106.2	523	106.2	523	106.2	523	5	7.6	44
	230	60	738	800	800	800	106.2	578	106.2	578	106.2	578	5	7.4	37
	380	60	447	600	500	500	64.3	355	64.3	355	64.3	355	5	4.5	23.1
	460	60	372	400	400	400	53.1	290	53.1	290	53.1	290	5	4	19
	575	60	295	400	350	350	42.5	255	42.5	255	42.5	255	5	2.9	15.3

NOTES:

1. Reference PIN 59 for pump models.
2. Use this table along with Pump Electrical Data on page 47 to determine electrical data of the unit plus the pump.
3. Does not include the Control Transformer on page 41)

Wiring Diagram

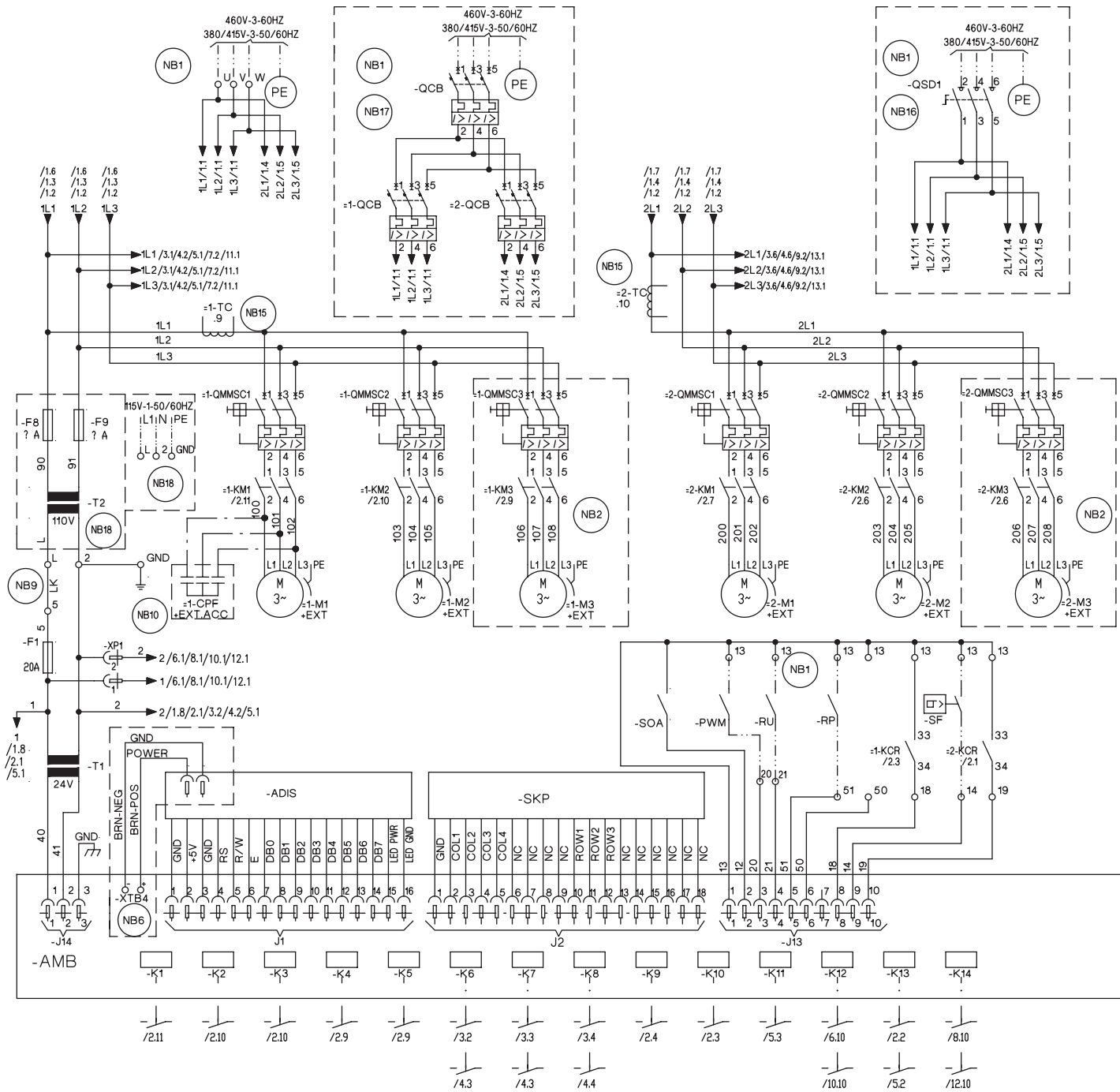

Wiring Diagram (Cont'd)

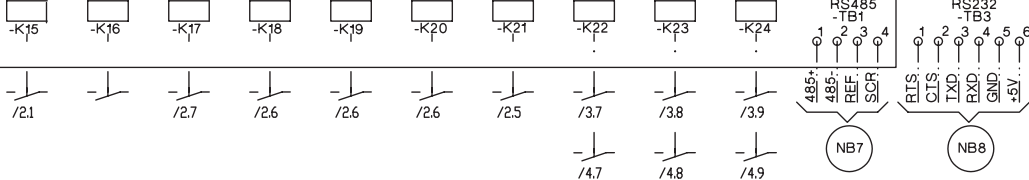
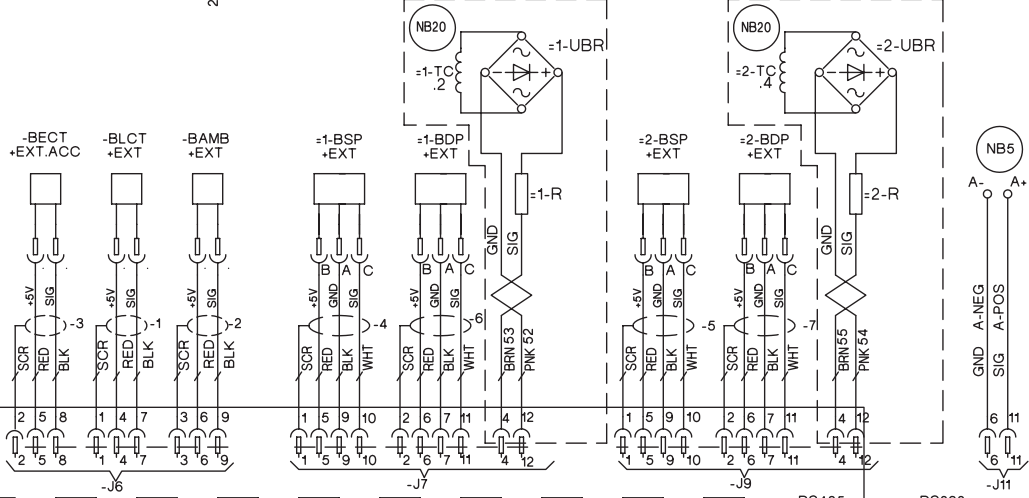
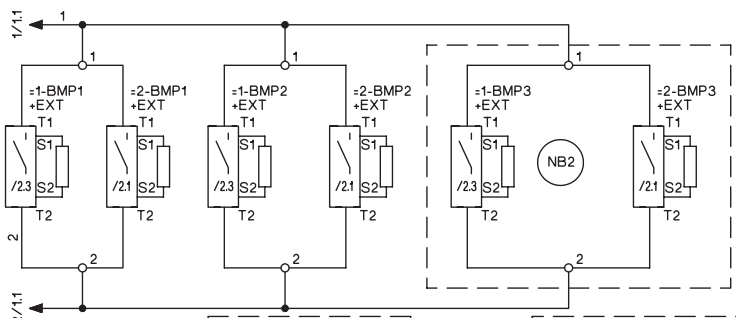
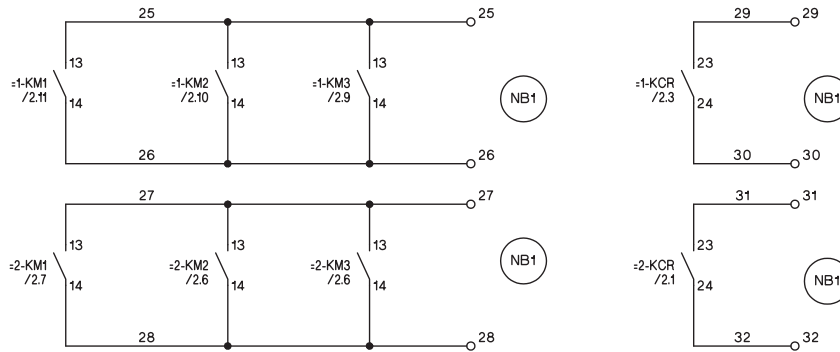

LD18444

User Control Wiring

USER CONTROL WIRING INPUTS

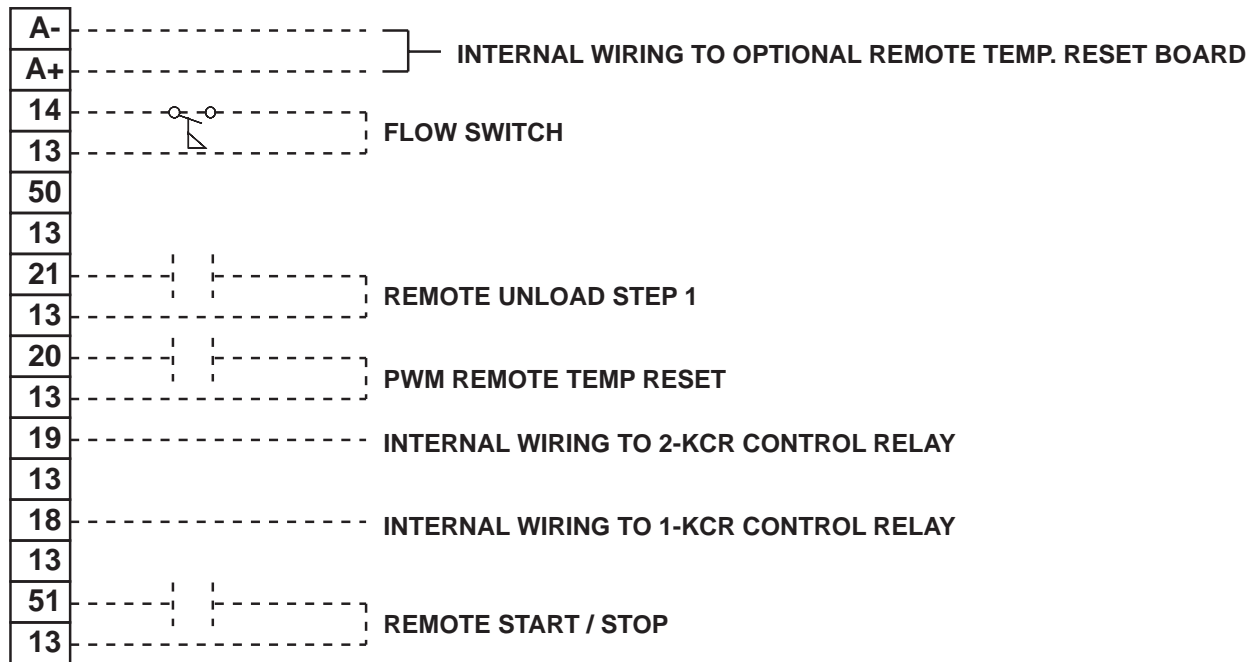

XTBC1

USER CONTROL WIRING OUTPUTS

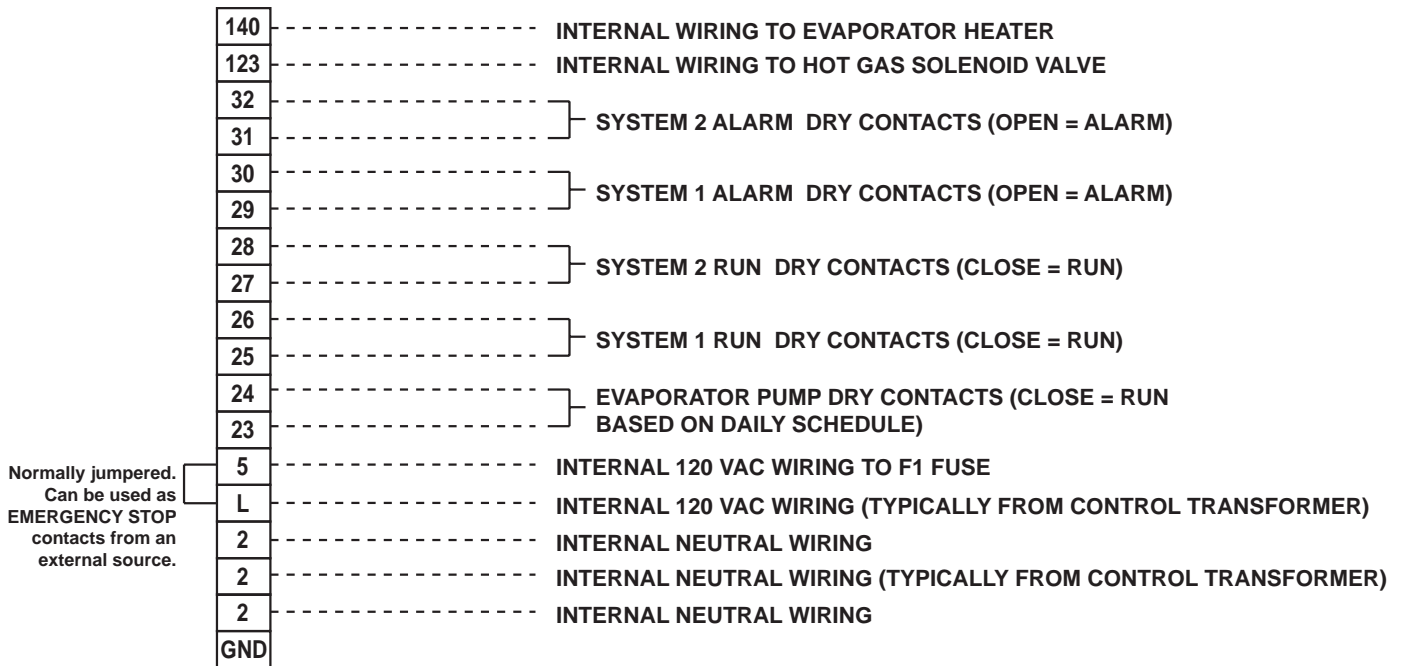

XTBC2

Notes

Designation	DESCRIPTION
ACC	ACCESSORY
- ADIS	DISPLAY BOARD
- AMB	MICRO BOARD

- BAMB	AMBIENT
- BDP	DISCHARGE PRESSURE
- BECT	ENTERING CHILLED TEMPERATURE
- BLCT	LEAVING CHILLED TEMPERATURE
	NOT FITTED ON REMOTE EVAP UNITS

- BMP	MOTOR PROTECTOR COMPRESSOR
- BSP	SUCTION PRESSURE

- CPF	CAPACITOR POWER FACTOR
-------	------------------------

- ECH	CRANKCASE HEATER
- EEH	EVAPORATOR HEATER
- EPH	PUMP HEATER
- EXT	EXTERNAL TO CONTROL PANEL

- F	FUSE
- FHP	HIGH PRESSURE CUTOUT
- FSI	FAN SPEED INHIBIT TWO SPEED FAN OPTION ONLY

GND	GROUND
G/Y	GREEN / YELLOW

J	PLUG BOARD CONNECTOR
---	----------------------

- K	CIRCUIT BOARD RELAY
- KF	FAN CONTACTOR LINE
- KFH	FAN CONTACTOR HIGH SPEED (INCLUDING COIL SUPPRESSOR)
- KFL	FAN CONTACTOR LOW SPEED (INCLUDING COIL SUPPRESSOR)
- KFOL	FAN OVERLOAD
- KFS	RELAY FAN SPEED
- KM	COMPRESSOR CONTACTOR (INCLUDING COIL SUPPRESSOR)
- KCR	CONTROL RELAY
- KP	PUMP CONTACTOR PART (INCLUDING COIL SUPPRESSOR)

- M	COMPRESSOR MOTOR
- MF	MOTOR FAN
- MP	MOTOR PUMP

NU	NOT USED
----	----------

PE	PROTECTIVE EARTH
PWM	PULSE WIDTH MODULATION TEMP RESET or REMOTE UNLOAD 2nd STEP

Designation	DESCRIPTION
- QCB	CIRCUIT BREAKER
- QMMS	MANUAL MOTOR STARTER COMPRESSOR
- QMMSP	MANUAL MOTOR STARTER PUMP
- QSD	SWITCH DISCONNECT

R	RESISTOR
RED	RED
RP	RUN PERMISSIVE
RU	REMOTE UNLOAD 1st STEP

SCR	SCREEN
- SF	FLOW SWITCH
- SKP	KEYPAD
- SOA	SWITCH OFF AUTO

- T	TRANSFORMER
- TC	TRANSFORMER CURRENT

- UBR	BRIDGE RECTIFIER
-------	------------------

WHT	WHITE
-----	-------

- XTBC	TERMINAL BLOCK CUSTOMER
- XTBF	TERMINAL BLOCK FACTORY

- YHGSV	HOT GAS SOLENOID VALVE (INCLUDING COIL SUPPRESSOR)
- YLLSV	LIQUID LINE SOLENOID VALVE (INCLUDING COIL SUPPRESSOR) FIELD MOUNTED AND WIRED ON REMOTE EVAP UNITS

- ZCPR	COMPRESSOR
--------	------------

	NOTE WELL (SEE NOTE)
---	----------------------

- - - - -	WIRING AND ITEMS SHOWN THUS ARE STANDARD YORK ACCESSORIES
-----------	--

- · - · - · - · -	WIRING AND ITEMS SHOWN THUS ARE NOT SUPPLIED BY YORK
-------------------	---

- - - - -	ITEMS THUS ENCLOSED FORM A COMPONENTS OR SETS OF COMPONENTS
-----------	--

Notes (Cont'd)

- A. This drawing is based on IEC symbols.
 - B. Field wiring to be in accordance with the relevant electrical code as well as all other applicable codes and specifications
 - C. All sources of supply shown on this diagram to be taken from one main isolator, not shown or supplied by the chiller manufacturer .
 - D. Green and yellow wire is used for earth, multi-coloured cable used for low voltage. Red wire used for AC control, blue wire for neutral, black wire for AC and DC power. Orange wire should be used for interlock control wiring supplied by external source.
 - E. Legend designation depicts component abbreviations. Number prefix located, if applicable, on schematic circuit, refers to system thereon, e.g.= 1-FHP2 refers to high pressure cutout no 2 on system no 1.
 - F. All wiring to control section voltage free contacts requires a supply provided by the customer maximum voltage 240 volts. The customer must take particular care when deriving the supplies for the voltage free terminals with regard to a common point of isolation. Thus, these circuits when used must be fed via the common point of isolation the voltage to these circuits is removed when the common point of isolation to the unit is opened. This common point of isolation is not supplied. The voltage free contacts are rated at 100VA. All inductive devices {relays} switch by the voltage free contacts must have their coil suppressed using standard r/c suppressors.
 - G. Customer voltage free contacts connected to terminal 13 must be rated at 30v 5ma
 - H. No controls {relays etc.} Should be mounted in any section of the control panel. Additionally, control wiring not connected to the control panel should not be run through the panel. If these precautions are not followed, electrical noise could cause malfunctions or damage to the unit and its controls.
1. Refer to installation commissioning operation and maintenance manual for customer connections and customer connection notes, non compliance to these instructions will invalidate unit warranty.
 2. Wiring and components for compressor 3 only fitted when unit has 3 compressors on the system. 1-BMP3 is replaced by a link across terminals 134 & 135. 2-BMP3 is replaced by a link across terminals 234 & 235.
 3. FHP2 is only fitted on 0089 and above. When not fitted 1-FHP2 is replaced by a link across terminals 132 & 139. 2-FHP2 is replaced by a link across terminals 232 & 239
 4. Fitted on units with hot gas bypass option.
 5. EMS option is wired as shown
 6. This wiring must be used for old display 031-0110-000
 7. Network connection point
 8. Printer port
 9. Remote emergency stop can be wired between terminal 1 and 5 after removing link
 10. Power factor correction accessory. Power factor correction fitted to each compressor contactor
 11. Not fitted on compressors with internal motor protection. For system 1 terminals 132 & 133, 133 & 134 And 134 & 135 are linked. For system 2 terminals 232 & 233, 233 & 234 and 234 & 235 are linked.
 12. Only fitted on systems with 3 or 4 fans
 13. Only fitted on systems with 4 fans
 14. Only fitted on systems with 5 fans
 15. Only fitted on systems with 6 fans
 16. Input switch disconnect or circuit breaker option replaces input terminal block
 17. Input switch disconnect & system circuit breaker option replaces input terminal block
 18. 115V control circuit requires a 115V supply unless control circuit transformer-T2 & -F3 are fitted
 19. For optional hydro kit. Heater -EPH is fitted and wired as shown. On single pump -KP1, -QMMSP1 and -MP1 are fitted & wired as shown. On two pump hydro kits -KP2, -QMMSP2 & -MP2 are also fitted and wired as shown.
 20. Current measurement option wired as shown
 21. Only fitted on systems with single speed fans
 22. Only fitted on systems with two speed fans
 23. Optional compressor manual motors starters.
 24. See sheet 3 of connection diagram for power input options

Application Data

UNIT LOCATION

The YLAA chillers are designed for outdoor installation. When selecting a site for installation, be guided by the following conditions:

- A. For outdoor locations of the unit, select a place having an adequate supply of fresh air for the condenser.
- B. Avoid locations beneath windows or between structures where normal operating sounds may be objectionable.
- C. Installation sites may be either on a roof, or at ground level. (See FOUNDATION.)
- D. The condenser fans are the propeller-type, and are not recommended for use with duct work in the condenser air stream.
- E. When it is desirable to surround the unit(s), it is recommended that the screening be able to pass the required chiller CFM without exceeding 0.1" of water external static pressure.
- F. Protection against corrosive environments is available by supplying the units with epoxy coating on the condenser coils. The epoxy coils should be offered with any units being installed at the seashore or where salt spray may hit the unit.

In installations where winter operation is intended and snow accumulations are expected, additional height must be provided to ensure normal condenser air flow.

Recommended clearances for units are given in Dimensions. When the available space is less, the unit(s) must be equipped with the discharge pressure transducer option to permit high pressure unloading in the event that air recirculation were to occur.

FOUNDATION

The unit should be mounted on a flat and level foundation, ground or roof, capable of supporting the entire operating weight of the equipment. Operating weights are given in the *Physical Data and Nominal Ratings on page 22 tables*.

Roof Locations – Choose a spot with adequate structural strength to safely support the entire weight of the unit and service personnel. Care must be taken not to damage the roof during installation. If the roof is “bonded”, consult the building contractor or architect for special installation requirements. Roof installations should incorporate the use of spring-type isolators to minimize the transmission of vibration into the building structure.

Ground Level Installations – It is important that the units be installed on a substantial base that will not settle, causing strain on the liquid lines and resulting in possible leaks. A one-piece concrete slab with footers extending below the frost line is highly recommended. Additionally, the slab should not be tied to the main building foundation as noises will telegraph.

Mounting holes (5/8" diameter) are provided in the steel channel for bolting the unit to its foundation. See *Unit Dimensions on page 26*.

Application Data (Cont'd)

For ground level installations, precautions should be taken to protect the unit from tampering by or injury to unauthorized persons. Screws on access panels will prevent casual tampering; however, further safety precautions, such as unit enclosure options, a fenced-in enclosure, or locking devices on the panels may be advisable. Check local authorities for safety regulations.

CHILLED LIQUID PIPING

The chilled liquid piping system should be laid out so that the circulating pump discharges into the evaporator. The inlet and outlet evaporator liquid connections are given in *Unit Dimensions on page 26*.

Hand stop valves are recommended for use in all lines to facilitate servicing. Drain connections should be provided at all low points to permit complete drainage of the evaporator and system piping. Additionally, a strainer (20 mesh) is recommended for use on the INLET line to the evaporator.

Pressure gauge connections are recommended for installation in the inlet and outlet water lines. Gauges are not furnished with the unit and are to be furnished by other suppliers.

The chilled liquid lines that are exposed to outdoor ambients should be wrapped with a supplemental heater cable and covered with insulation. As an alternative, ethylene glycol should be added to protect against freeze-up during low ambient periods.

A flow switch is available as an accessory on all units. The flow switch (or its equivalent) must be installed in the leaving water piping of the evaporator and must not be used to start and stop the unit.

Guide Specifications

PART 1 – GENERAL

1.01 SCOPE

- A. The requirements of this Section shall conform to the general provisions of the Contract, including General and Supplementary Conditions, Conditions of the Contract, and Contract Drawings.
- B. Provide microprocessor-controlled, multiple-scroll compressor, air-cooled, liquid chillers of the scheduled capacities as shown and indicated on the drawings, including but not limited to:
 - 1. Chiller package with zero ozone depletion potential Refrigerant R-410A
 - 2. Electrical power and control connections
 - 3. Chilled water connections
 - 4. Manufacturer start-up
 - 5. Charge of refrigerant and oil.

1.02 QUALITY ASSURANCE

- A. Products shall be Designed, Tested, Rated and Certified in accordance with, and Installed in compliance with applicable sections of the following Standards and Codes:
 - 1. AHRI 550/590 and 551/591– Water Chilling Packages Using the Vapor Compression Cycle
 - 2. AHRI 370 – Sound Rating of Large Outdoor Refrigerating and Air-Conditioning Equipment
 - 3. ANSI/ASHRAE 15 – Safety Code for Mechanical Refrigeration
 - 4. ANSI/ASHRAE 34 – Number Designation and Safety Classification of Refrigerants
 - 5. ASHRAE 90.1 – Energy Standard for Buildings Except Low-Rise Residential Buildings
 - 6. ANSI/NFPA 70 – National Electrical Code (N.E.C.)
 - 7. ASME Boiler and Pressure Vessel Code, Section VIII, Division 1
 - 8. OSHA – Occupational Safety and Health Act
 - 9. Manufactured in facility registered to ISO 9001
 - 10. Conform to Intertek Testing Services for construction of chillers and provide ETL/cETL Listed Mark

Guide Specifications (Cont'd)

- B. Factory Run Test: Chiller shall be pressure-tested, evacuated and fully charged with refrigerant and oil, and shall be factory operational run tested with water flowing through the vessel.
- C. Chiller manufacturer shall have a factory trained and supported service organization.
- D. Warranty: Manufacturer shall Warrant all equipment and material of its manufacture against defects in workmanship and material for a period of eighteen (18) months from date of shipment or twelve (12) months from date of start-up, whichever occurs first.

1.03 DELIVERY AND HANDLING

- A. Unit shall be delivered to job site fully assembled with all interconnecting refrigerant piping and internal wiring ready for field installation and charged with refrigerant and oil by the Manufacturer.
- B. Provide protective covering over vulnerable components for unit protection during shipment. Fit nozzles and open ends with plastic enclosures.
- C. Unit shall be stored and handled per Manufacturer's instructions.

PART 2 - PRODUCTS

2.01 CHILLER MATERIALS AND COMPONENTS

- A. General: Install and commission, as shown on the schedules and plans, factory assembled, charged, and tested air cooled scroll compressor chiller(s) as specified herein. Chiller shall be designed, selected, and constructed using a refrigerant with Flammability rating of "1", as defined by ANSI/ASHRAE STANDARD 34 Number Designation and Safety Classification of Refrigerants. Chiller shall include not less than two refrigerant circuits above 50 tons (200kW), scroll compressors, direct-expansion type evaporator, air-cooled condenser, refrigerant, lubrication system, interconnecting wiring, safety and operating controls including capacity controller, control center, motor starting components, and special features as specified herein or required for safe, automatic operation.
- B. Cabinet: External structural members shall be constructed of heavy gauge, galvanized steel coated with baked on powder paint which, when subject to ASTM B117, 1000 hour, 5% salt spray test, yields minimum ASTM 1654 rating of "6".
- C. Operating Characteristics: Provide low and high ambient temperature control options as required to ensure unit is capable of operation from 30°F to 115°F (-1°C to 46°C) ambient temperature. [Optional: 0°F to 125°F (-18°C to 52°C) ambient.]
- D. Service Isolation valves: Discharge (ball type) isolation valves factory installed per refrigerant circuit.
- E. Includes a system high-pressure relief valve in compliance with ASHRAE15.
- F. Pressure Transducers and Readout Capability
 - 1. Discharge Pressure Transducers: Permits unit to sense and display discharge pressure.
 - 2. Suction Pressure Transducers: Permits unit to sense and display suction pressure.

Guide Specifications (Cont'd)

3. High Ambient Control: Allows units to operate when the ambient temperature is above 115°F (46°C). Includes discharge pressure transducers.

2.02 COMPRESSORS

A. Compressors: Shall be hermetic, scroll-type, including:

1. Compliant design for axial and radial sealing
2. Refrigerant flow through the compressor with 100% suction cooled motor.
3. Large suction side free volume and oil sump to provide liquid handling capability.
4. Compressor crankcase heaters to provide extra liquid migration protection.
5. Annular discharge check valve and reverse vent assembly to provide low-pressure drop, silent shutdown and reverse rotation protection.
6. Initial oil charge.
7. Oil level sight glass.
8. Vibration isolator mounts for compressors.
9. Brazed-type connections for fully hermetic refrigerant circuits.
10. Compressor Motor overloads capable of monitoring compressor motor current. Provides extra protection against compressor reverse rotation, phase-loss and phase-imbalance

2.03 REFRIGERANT CIRCUIT COMPONENTS

Each refrigerant circuit shall include: a discharge service ball type isolation valve, high side pressure relief, liquid line shutoff valve with charging port, low side pressure relief device, filter-drier, solenoid valve, sight glass with moisture indicator, thermostatic expansion valves [**Option:** electronic expansion valves], and flexible, closed-cell foam insulated suction line and suction pressure transducer.

2.04 HEAT EXCHANGERS

A. Evaporator :

1. Evaporator shall be brazed-plate stainless steel construction capable of refrigerant working pressure of 450 psig (3103 kPa) and liquid side pressure of 150 psig (1034 kPa) (Option for 300 psig [2068 kPa] available).
2. Brazed plate heat exchangers shall be UL listed.
3. Exterior surfaces shall be covered with 3.4" (19mm), flexible, closed cell insulation, thermal conductivity of 0.26k ([BTU/ HR-Ft² -°F]/in.) maximum.
4. Water nozzles shall be provided with grooves for field provided ANSI/AWWA C-606 mechanical couplings.
5. Evaporator shall include vent and drain fittings and thermostatically controlled heaters to protect to -20°F (-29°C) ambient in off-cycle.

Guide Specifications (Cont'd)

6. A 20 mesh, serviceable wye-strainer and mechanical couplings shall be provided for field installation on evaporator inlet prior to startup.

[Option] Evaporator shall be provided with piping extension kit and mechanical couplings to extend liquid connection from evaporator to edge of unit. Thermal dispersion type flow switch shall be factory installed in the evaporator outlet pipe extension and wired to the unit control panel. Extension kit nozzle connections shall be ANSI/AWWA C-606 (grooved) Extension kit pipe insulation and heat trace to be field provided (if required).

B. Air Cooled Condenser:

1. Coils: Condenser coils shall be constructed of a single material to avoid galvanic corrosion due to dissimilar metals. Coils and headers are brazed as one piece. Integral sub cooling is included. Coils shall be designed for a design working pressure of 650 PSIG (45 bar). Condenser coil shall be washable with potable water under 100 psi (7 bar) pressure.
2. Low Sound Fans: Shall be dynamically and statically balanced, direct drive, corrosion resistant glass fiber reinforced composite blades molded into a low noise, full-airfoil cross section, providing vertical air discharge and low sound. Each fan shall be provided in an individual compartment to prevent crossflow during fan cycling. Guards of heavy gauge, PVC (polyvinyl chloride) coated or galvanized steel shall be factory installed.
3. Fan Motors: High efficiency, direct drive, 6 pole, 3 phase, insulation class "F", current protected, Totally Enclosed Air-Over (TEAO), rigid mounted, with double sealed, permanently lubricated, ball bearings.

2.05 CONTROLS

- A. General: Automatic start, stop, operating, and protection sequences across the range of scheduled conditions and transients.
- B. Power/Control Enclosure: Rain and dust tight NEMA 3R powder painted steel cabinet with hinged, latched, and gasket sealed door.
- C. Microprocessor Control Center:
 1. Automatic control of compressor start/stop, anti-coincidence and anti-recycle timers, automatic pumpdown at system shutdown, condenser fans, evaporator pump, evaporator heater, unit alarm contacts, and chiller operation from 0°F to 125°F (-18°C to 52°C) ambient. Automatic reset to normal chiller operation after power failure.
 2. Remote water temperature reset via 0-10 VDC or 4-20 mA input signal or up to two steps of demand (load) limiting.
 3. Software stored in non-volatile memory, with programmed setpoints retained in lithium-battery -backed real-time-clock (RTC) memory for minimum 5 years.
 4. Forty character liquid crystal display, descriptions in English (or Spanish, French, Italian, or German), numeric data in English (or Metric) units. Sealed keypad with sections for Setpoints, Display/Print, Entry, Unit Options & clock, and On/Off Switch.

Guide Specifications (Cont'd)

5. Programmable Setpoints (within Manufacturer limits): display language; chilled liquid temperature setpoint and range, remote reset temperature range, daily schedule/holiday for start/stop, manual override for servicing, low and high ambient cut-outs, low liquid temperature cut-out, low suction pressure cut-out, high discharge pressure cut-out, anti-recycle timer (compressor start cycle time), and anti-coincident timer (delay compressor starts).
 6. Display Data: Return and leaving liquid temperatures, low leaving liquid temperature cut-out setting, low ambient temperature cut-out setting, outdoor air temperature, English or metric data, suction pressure cut-out setting, each system suction pressure, discharge pressure (optional), liquid temperature reset via a 4-20 milliamp or 0-10 VDC input, anti-recycle timer status for each compressor, anti-coincident system start timer condition, compressor run status, no cooling load condition, day, date and time, daily start/stop times, holiday status, automatic or manual system lead/lag control, lead system definition, compressor starts/operating hours (each), status of hot gas valves, evaporator heater and fan operation, run permissive status, number of compressors running, liquid solenoid valve status, load & unload timer status, water pump status.
 7. System Safeties: Shall cause individual compressor systems to perform auto shut down; manual reset required after the third trip in 90 minutes. System Safeties include: high discharge pressure, low suction pressure, high pressure switch, and motor protector. Compressor motor protector shall protect against damage due to high input current or thermal overload of windings.
 8. Unit Safeties: Shall be automatic reset and cause compressors to shut down if low ambient, low leaving chilled liquid temperature, under voltage, and flow switch operation.
 9. Alarm Contacts: Low ambient, low leaving chilled liquid temperature, low voltage, low battery, and (per compressor circuit): high discharge pressure, and low suction pressure.
 10. BAS Communications: YORKTalk 2, BACnet MS/TP, Modbus and N2 communication capabilities are standard. (Option: LON communication via ELink Microgateway)
- D. Manufacturer shall provide any controls not listed above, necessary for automatic chiller operation. Mechanical Contractor shall provide field control wiring necessary to interface sensors to the chiller control system.

2.06 POWER CONNECTION AND DISTRIBUTION

A. Power Panels:

1. NEMA 3R raintight, powder painted steel cabinets with hinged, latched, and gasket sealed outer doors. Provide main power connection(s), control power connections, compressor and fan motor start contactors, current overloads, and factory wiring.

Guide Specifications (Cont'd)

2. Power supply shall enter unit at a single location, be 3 phase of scheduled voltage, and connect to individual terminal blocks per compressor. Separate disconnecting means and/or external branch circuit protection (by Contractor) required per applicable local or national codes.

B. Compressor, control and fan motor power wiring shall be located in an enclosed panel or routed through liquid tight conduit.

2.07 ACCESSORIES AND OPTIONS

Some accessories and options supercede standard product features. Your Johnson Controls representative will be pleased to provide assistance.

A. Microprocessor controlled, Factory installed Across-the-Line type compressor motor starters as standard.

B. Outdoor Ambient Temperature Control

1. Low Ambient Control: Permits unit operation to 0°F ambient. Standard unit controls to 30°F ambient.
2. High Ambient Control: Permits unit operation above 115°F ambient.

C. Power Supply Connections:

1. Single Point Power Supply: Single point Terminal Block for field connection and interconnecting wiring to the compressors. Separate external protection must be supplied, by others, in the incoming power wiring, which must comply with the National Electric Code and/or local codes.
2. Single Point or Multiple Point Disconnect: Single or Dual point Non-Fused Disconnect(s) and lockable external handle (in compliance with Article 440-14 of N.E.C.) can be supplied to isolate the unit power voltage for servicing. Separate external fusing must be supplied, by others, in the incoming power wiring, which must comply with the National Electric Code (CE) and/or local codes.
3. Single Point Circuit Breaker: Single point Terminal Block with Circuit Breaker and lockable external handle (in compliance with Article 440-14 of N.E.C.) can be supplied to isolate power voltage for servicing. Incoming power wiring must comply with the National Electric Code and/or local codes.

D. Control Power Transformer: Converts unit power voltage to 120-1-60 (500 VA capacity). Factory-mounting includes primary and secondary wiring between the transformer and the control panel.

E. Power Factor Correction Capacitors: Provided to correct unit compressor factors to a 0.90-0.95.

F. Condenser Coil Environmental Protection:

1. Post-Coated Dipped: Dipped-cured coating on condenser coils for seashore and other corrosive applications (with the exception of strong alkalis, oxidizers, and wet bromine, chlorine and fluorine in concentrations greater than 100 ppm).

Guide Specifications (Cont'd)

G. Protective Chiller Panels (Factory or Field Mounted)

1. Louvered Panels (condenser coils only): painted steel as per remainder of unit cabinet, over external condenser coil faces.
2. Wire Panels (full unit): Heavy gauge, welded wire- mesh, coated to resist corrosion, to protect condenser coils from incidental damage and restrict unauthorized access to internal components.
3. Louvered Panels (full unit): painted steel as per remainder of unit cabinet, to protect condenser coils from incidental damage, visually screen internal components, and prevent unauthorized access to internal components.
4. Louvered/Wire Panels: louvered steel panels on external condenser coils painted as per remainder of unit cabinet. Heavy gauge, welded wire-mesh, coated to resist corrosion, around base of machine to restrict unauthorized access.
5. End Louver (hail guard): louvered steel panels on external condenser coil faces located at the ends of the chiller.

H. Thermal Dispersion Flow Switch (Factory installed and wired in piping extension kit): normally open, 30 bar pressure rating, stainless steel 316L construction, IP67, -4°F to 158°F ambient rating.

I. Evaporator options:

1. Provide 1-1/2" evaporator insulation in lieu of standard 3/4".

J. Hot Gas By-Pass: Permits continuous, stable operation at capacities below the minimum step of unloading to as low as 5% capacity (depending on both the unit & operating conditions) by introducing an artificial load on the evaporator. Hot gas by-pass is installed on only one refrigerant circuit.

K. Thermal Storage: leaving chilled liquid setpoint range for charge cycle from 25°F to 20°F minimum, with automatic reset of the leaving brine temperature up to 40°F above the setpoint.

L. Low Temperature Process Glycol: leaving chilled liquid setpoint range 10°F to 50°F (-12°C to 10°C)

M. Chicago Code Relief Valves to meet Chicago Code requirements.

N. Sound Reduction (Factory installed):

1. Ultra Quiet - Low speed, reduced noise fans
2. Compressor Acoustic Sound Blankets

O. Vibration Isolation (Field installed):

1. Elastomeric Isolators.
2. 1" Deflection Spring Isolators: level adjustable, spring and cage type isolators for mounting under the unit base rails.

Guide Specifications (Cont'd)

3. 2" Deflection Restrained Spring Isolators: level adjustable, restrained mounts in rugged welded steel housing with vertical and horizontal limit stops. Housings shall be designed to withstand a minimum 1.0g accelerated force in all directions to 2 inches (50.8 mm)

PART 3 – EXECUTION

3.01 INSTALLATION

- A. General: rig and install in full accordance with manufacturer's requirements, project drawings, and contract documents.
- B. Location: locate chiller as indicated on drawings, including cleaning and service maintenance clearance per manufacturer instructions. Adjust and level chiller on support structure.
- C. Components: installing contractor shall provide and install all auxiliary devices and accessories for fully operational chiller.
- D. Electrical: co-ordinate electrical requirements and connections for all power feeds with electrical contractor (Division 16).
- E. Controls: co-ordinate all control requirements and connections with controls contractor.
- F. Finish: installing contractor shall paint damaged and abraded factory finish with touch-up paint matching factory finish.

Notes

